



NATIONAL OPEN UNIVERSITY OF NIGERIA

COURSE CODE :PED 237

**COURSE TITLE:
MEASUREMENTS AND SHAPES**

**COURSE
GUIDE****PED 237****MEASUREMENTS AND SHAPES**Course WritersDr. S. M. RaimiOyo State College of Education
Oyo

&

Dr. Femi, A. Adeoye
National Open University of Nigeria

Course Developer

Dr. Femi, A. Adeoye
National Open University of Nigeria

Course Editor

Dr. Lucy Eraikhuemen
Department of Educational Psychology and
Curriculum Studies
University of Benin, Benin-City

Programme Leader

Dr. M.F. Ogunsola-Bandele
National Open University of Nigeria

Course Coordinator

Dr. Femi, A. Adeoye
National Open University of Nigeria**NATIONAL OPEN UNIVERSITY OF NIGERIA**

National Open University of Nigeria
Headquarters
14/16 Ahmadu Bello Way
Victoria Island
Lagos

Abuja Office
No. 5 Dar es Salaam Street
Off Aminu Kano Crescent
Wuse II, Abuja
Nigeria

e-mail: centralinfo@nou.edu.ng
URL: www.nou.edu.ng

Published by
National Open University of Nigeria

Printed 2008

ISBN: 978-058-053-0

All Rights Reserved

CONTENTS	PAGE
Introduction	1
Course Aims	1
Course objectives	1
Working through this Course	2
Course Materials	3
Study Units	3
Textbooks and References	4
Assessment	5
Final Examination and Grading	5
Summary	5

Introduction

Primary education provides the basic foundation upon which all other forms of education rest; hence the need to acquaint would-be and serving teachers at this level of education with relevant knowledge, skills, methods and materials to enable them teach effectively all subjects in the primary school curriculum.

As primary educators, you are saddled with the onerous task of having to draw from your wide range of knowledge and skills to be able to teach a wide range of school subjects in the curriculum. To enable you achieve this goal, you need to be exposed to a wide range of materials such as this (i.e. measurements and shapes).

In addition some teachers, most often than not tend to develop phobia for science and mathematics related subjects. As primary school teachers with the assiduous task of being the ‘lord’ of all subjects in your classrooms, being exposed to materials such as contained in this course, will not only remove this phobia but rather provide the basis for effective teaching of science and mathematics related subjects at the primary school level as contained in the primary schools curriculum.

With this view in mind, this course had been designed in such a way that you will learn about issues and concepts that will prepare you for the tasks ahead as primary educators.

The course is made up of 15 teaching units. They include materials which bother on measurements, units of measurement, unit conversion, significant figures and uncertainties in measurements. The course also dealt extensively with geometrical shapes, simple 2-dimensional and three dimensional solids, determination of areas and volumes of these solids and simple geometrical constructions. The course also include a

course guide which shed light on what to do as you run through the content in such a way that you will find the content interesting and enjoyable. There are also regular tutorial classes that are linked to the course. You are advised to attend all the sessions, to enable you benefit maximally from this course.

Course Aims

The major aim of the course ‘shapes and measurement’ is to expose professional primary school teachers to materials, which provide them with wide range of knowledge about some basic ideas in measurement and geometrical shapes. Therefore, it is hoped that as you go through this course, you will be exposed to some basic concepts about measurements such as customized and derived units, basic units, etc. You will also learn about simple geometrical shapes, plane figures and simple constructions.

Course Objectives

In order to achieve the broad aims set, the course sets its overall objectives. Thus, there are specific objectives, stated at the beginning of each unit. These objectives are stated in specific and achievable terms. You will need to digest and assimilate these objectives before you start working through each of the units.

You will benefit immensely from the content of this course if you make them your focus as you run through each of the units. This will enable you check your progress. After going through the unit, try and read over the unit objectives. By doing this, you will be sure that you are doing what is expected of you by the unit.

After you must have successfully completed the study of this course you should be able to:

- i. Define and explain the term ‘measurement’
- ii. Identify the basic units and standard units of measurement
- iii. Perform simple calculations involving changing from one unit of measurement to another.
- iv. Define the term “uncertainty” in measurement
- v. Identify the role of uncertainty in measurement.
- vi. Identify some 3-Dimensional shapes and list their properties.
- vii. Identify plane shapes and state their properties.
- viii. Determine the perimeters of simple plane shapes
- ix. Calculate the areas of simple plane shapes
- x. Calculate the curved and surface areas of simple solid objects.
- xi. Solve simple problems relating to volumes of simple solid figures.

- xii. Distinguish between ‘construction’ and ‘Drawing’
- xiii. Define and explain the locus of a point.
- xiv. List some common loci.
- xv. Perform some simple geometrical constructions.

Working through this Course

Studying this course behoves you to read the study units, suggested text books and other materials prescribed by the National open university of Nigeria (NOUN).

Each unit contains series of self assessment exercises at some designated points in the course. There is need for you to attempt all these exercises to enable you ascertain the extent of your progress in the course. The course also contains tutor marked assignment at the end of each unit. You are expected to provide answers to these TMAS and get them submitted at dates, which will be given by your tutorial facilitator(s). TMAS are very important to enable you scale through the course after the examinations.

Course Materials

The major components of the course are:

- Course outline
- Course guide
- Study units
- Recommended textbooks.

Study Units

There are two modules comprising 15 units in this course. They are as follows:

Module 1

Unit 1	Measurement and Calculations
Unit 2	Standard Unit of Measurement
Unit 3	Significant Figures
Unit 4	Unit Conversions and Calculations
Unit 5	Definition of Density
Unit 6	Basic and Derived Units
Unit 7	Uncertainties in Measurement

Module 2

Unit 1	Kinds and Properties of Lines, Angles and Triangles
Unit 2	Solids or 3-dimensional shapes
Unit 3	Plane Shapes
Unit 4	Perimeters of Plane Shapes
Unit 5	Areas
Unit 6	Curved and Total Surface Areas
Unit 7	Volumes of Simple Solids
Unit 8	Simple Geometrical Constructions

Each unit consists of introduction, objectives, the content, conclusion, summary and tutor marked assignment. Exercises are also provided to assist in achieving the stated objectives in each unit.

Textbooks and References

For the sake of broadening your knowledge about the content of this unit, you need to consult and read some relevant textbooks. Below is a list of some of these texts, you may wish to consult.

Anyakola, M. N. (2005). *New School Physics for Senior Secondary School*. Lagos: African First Publishers Ltd.

Darrell, D. E. Wentworth, J. O. (1995). *Introductory Chemistry*. USA: Houghton Mifflin Co.

Davde, Osuagwu N. M. Anemelu, C and Oyeozili, I. (2004). *New School Mathematics for Senior Secondary School*. Lagos: Africana First Publisher.

Fletcher, J. E. (1975). *Enjoying Mathematics in the Primary School*. Ibadan: Heinemann Educational Books Nigeria Ltd.

Obioma, G. *et al* (2003). *MAN Mathematics for Junior Secondary School 3*. Ibadan: University Press Limited.

Obioma, G. *et al* (1995). *STAN Mathematics for Junior Secondary Schools*. Ibadan: University Press Ltd.

Oajire, A. A. and Ayodele, E. T. (1999). *Introductory Physical Chemistry (University Series A.)*. Ibadan: Ogfat Publishers.

Olayanju, S. O. and Olosunde, G. R. (2001). *Teaching Primary Mathematics Curriculum and Shapes Measurement. A Text for Schools and Colleges Lagos*, SIBIS Ventures

Raimi, S. M., Bolaji, O. S., Agoro, A. A. Oyediran, M.A. (2003). *Basic Mathematics for Science Students*. Oyo : City Publisher

Swemoair J. P. and Bukett, A. R. (1997). *Introductory Chemistry*. USA.

Steve, A. and Jonathan, A. (2000). *Advanced Physics*. U. K.: Oxford University Press.

The above list of recommended textbooks is not exhaustive as there are other valuable and relevant textual materials in the market. Your tutorial facilitators may assist further with other suggested readings. You may wish also to consult nearby libraries for more knowledge about the content of the course. Suffice it to say that, the materials contained in this write-up are adequate enough to prepare you for the task ahead as primary educators.

Assessment

There are two main components of assessment for this course. The tutor marked assignment (TMA) and one end of course examination. Tutor marked Assignment (TMA).

TMA is the continuous assessment component of the course. It accounts for 30% of the total course. It is advisable to take this assignment with all seriousness as this will assist you in passing the course in the end.

You should ensure that the assignment gets to your facilitator on or before the expiration date. Always get in touch with your facilitator in case you would not be able to submit your TMA at the designated time.

Final Examination and Grading

This examination concludes the assessment for the course. It constitutes 70% of the whole course. You will be informed of the time for the examination.

Summary

This course intends to provide you with some underlying knowledge about measurements, its units and forms, and uncertainties in measurements. It also intends to expose you to knowledge about simple geometrical shapes and constructions. By the time you complete this course, you will be able to answer the following questions.

- Define the term ‘measurement’.

- a. What do you mean by (i) volume, (ii) mass
- (iii) temperature (iv) length (v) S. I. unit
 - b. State the S.I. units for measuring each of the quantities stated in 2a (i) – (v) above
- State the formula you would use in doing the following conversions.
 - $^{\circ}\text{C}$ to $^{\circ}\text{F}$
 - $^{\circ}\text{C}$ to $^{\circ}\text{K}$
 - $^{\circ}\text{F}$ to $^{\circ}\text{C}$
- a. List all the seven basic units of measurement.
 - b. Present a list of all derived units, which you have come across in this course.
- a. Define Density.
 - b. Write down the formula for determining the Density of an object.
- a. Mention any five 3-dimensional solids that you have studied in this course.
 - b. State the properties of the solids mentioned in 6 (a) above.
- a. List any four plane shapes.
 - b. State the properties of these plane shapes in 7(a)
- a. How can you distinguish between basic and derived units?
 - b. Write down the units for measuring the following quantities.
 - (i) area (ii) volume of a solid (iii) total surface areas
- a. Distinguish between accuracy and precision in measurement
 - b. What do you mean by (i) rounding off numbers (ii) significant figures?
- Find the volume of a sphere whose surface area is 1600cm^2 (take $\pi = 22/7$)
- Differentiate between a sphere and a cone.
- What do you mean by (i) vertex (ii) edge of a solid figure? Give examples.

Students should note that, there are many other questions that could arise on any aspect of this course. Hence, students should not be deceived as to feel that the above listed questions are exhaustive for the scope and content of materials contained in this course. Students should try to apply their practical experiences to tackling some other questions that may arise by running through the course.

We wish you the very best in the course as you go through the content. No doubt, you will find it interesting and useful.

Course Code	PED 237
Course Title	Measurements and Shapes
Course Writers	Dr. S. M. Raimi Oyo State College of Education Oyo
	&
	Dr. Femi, A. Adeoye National Open University of Nigeria
Course Developer	Dr. Femi, A. Adeoye National Open University of Nigeria
Course Editor	Dr. Lucy Eraikhuemen Department of Educational Psychology and Curriculum Studies, University of Benin, Benin-City
Programme Leader	Dr. M.F. Ogunsola-Bandele National Open University of Nigeria
Course Coordinator	Dr. Femi, A. Adeoye National Open University of Nigeria



NATIONAL OPEN UNIVERSITY OF NIGERIA

National Open University of Nigeria
Headquarters
14/16 Ahmadu Bello Way
Victoria Island
Lagos

Abuja Office
No. 5 Dar es Salaam Street,
Off Aminu Kano Crescent
Wuse II, Abuja
Nigeria

e-mail: centralinfo@nou.edu.ng

URL: www.nou.edu.ng

Published by
National Open University of Nigeria

Printed 2008

ISBN: 978-058-053-0

All Rights Reserved

CONTENTS		PAGE
Module 1	1
Unit 1	Measurements and Calculations	1
Unit 2	Standard Units of Measurement.....	10
Unit 3	Significant Figures	22
Unit 4	Unit Conversion and Calculations	32
Unit 5	Definition of Density	45
Module 2	52
Unit 1	Basic and Derived Unit.....	52
Unit 2	Uncertainties in Measurement.....	58
Unit 3	Lines, Angles and Triangles	65
Unit 4	Solids and 3-Dimensional Shapes	86
Unit 5	Plane Shapes and Their Properties	92
Module 3	101
Unit 1	Perimeter of Plane Shapes	101
Unit 2	Areas	117
Unit 3	Surface Areas of Solid Object (Three Dimensional Objects).....	129
Unit 4	Volume of Simple Solids	146
Unit 5	Simple Geometric Constructions	158

MODULE 1

Unit 1	Measurements and Calculations
Unit 2	Standard Units of Measurement
Unit 3	Significant Figures
Unit 4	Unit Conversion and Calculations
Unit 5	Definition of Density

UNIT 1 MEASUREMENTS AND CALCULATIONS

CONTENTS

1.0	Introduction
2.0	Objectives
3.0	Main Content
3.1	Definition of Terms Involved in Measurements
3.1.1	Accuracy
3.1.2	Precision
3.2	Measured Numbers and Unit
3.3	Writing Measurements in Scientific Notations
4.0	Conclusion
5.0	Summary
6.0	Tutor-Marked Assignment
7.0	References/Further Readings

1.0 INTRODUCTION

A vast majority of the numbers that scientists use come from measurements. Measurement can be defined as the act of determining the size or amount of something. Measurement always has two parts. One part is the magnitude (or size) of a measurement. This is the number. The other part is the unit, which compares a measurement to a standard. For example if a man weights 103 kilograms, the 103 is the magnitude, and the kilogram is the unit. This means that the magnitude depends largely on the unit. To a scientist, the magnitude is meaningless without the unit. Very few quantities consist of numbers (magnitude) without units.

2.0 OBJECTIVES

By the end of this unit students would be able to:

- define and illustrate terms involved in measurement
- state two component parts of a measurement
- give an example of how you would use a standard measure (unit) in making a measurement
- convert numbers in decimal form to scientific notation and vice versa.

3.0 MAIN CONTENT

3.1 Definition of Terms Involved in Measurements

When scientists take measurements, they are seeking the true value of the quantity they are measuring. A typical procedure for this is to repeat measurements several times and then average the results. This process tends to even out random errors and fluctuation in the measurements and also points out where mistake has been made. Therefore average can be defined as “the sum of measurements divided by the number of measurements that have been made”. Mathematically expressed,

$$\text{Average} = \frac{\text{measurement 1} + \text{measurement 2} + \dots}{\text{Number of measurements}}$$

3.1.1 Accuracy

If you know the true value of a measured quantity, you can compare the average to that value. A reasonable agreement between the average and the true value shows that the measurements have accuracy. Accuracy can then be defined as the degree of agreement between measured value and accepted true value of a quantity.

3.1.2 Precision

In the same vein, one can compare the individual measured values to the average result. If the differences are relative, then measurements have precision, if the measurement scatter all over, they are not precise, and there may be no calculation procedure. Precision therefore means, the degree of agreement between individual measured values in a series of measurement and the average value.

For example, suppose the 103 kg man mentioned earlier on stepped on three different office scales and obtained measurements of 101, 104 and 107 kilogrammes. The average number is

$$\frac{101 + 104 + 107 \text{kg}}{3} = 104 \text{ kg}$$

The person's true value is 103kg, and the average is only 1 kg away from the average measurement, so the measurements are accurate. However, the individual values are scattered over a range of 6 kg. This means that the precision of these measurements is poor.

A set of measurements can have one of four possible combinations of accuracy and precision.

- i) A set of measurements can be both accurate and precise (the most desirable combination)
- ii) A set of measurements can be accurate but not precise (sometimes acceptable)
- iii) A set of measurements can be precise but not accurate (usually the result of consistent mistake).
- iv) A set of measurements can be neither accurate nor precise (not useful).

Example 1.1

In a house shoe pitching contest four people tossed three horseshoes each. Their results are shown in figure 2 below:

- (a) Which person's tosses illustrate most clearly neither precision nor accuracy?
- (b) Which person's tosses illustrate most clearly accuracy but not precision?

Solutions

- a) Measurements that are not precise are far apart, measurements that are not accurate are far from the correct value. Person 4's tosses best fit this description.
- b) When measurements are accurate, their average is close to the correct value. They can be accurate without being close together (i.e. they don't have to be precise in order to be accurate) person's I results best fit this description.

SELF ASSESSMENT EXERCISE 1

Which of the results in Example 1 best illustrates?

1. Precision but not accuracy.
2. Both accuracy and precision?

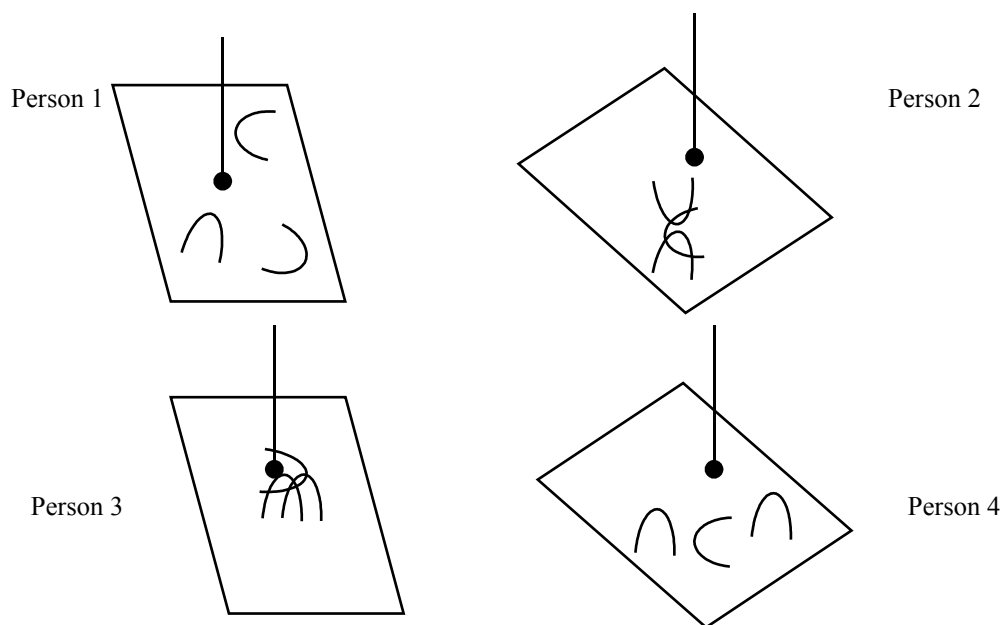
**SELF ASSESSMENT EXERCISE 2**

Define and explain the following terms:

- i) Average
- ii) Precision
- iii) Accuracy

3.2 Measured Numbers and Units

As stated earlier, there are two aspects of measurement, the measured number and a unit of measurement. For example an athlete who runs a distance of 20 kilometers. The 20 is the measured number and the unit is the kilometer. However, the essence of any measurement of a quantity is a comparison with some standard measure for that quantity which is the unit. The comparison results in a measured number which gives the multiples or fractions of that unit in the measured quantity.

3.3 Writing Measurements in Scientific Notation

If you used a scientific calculator, you may be familiar with the use of scientific notation in writing numbers. Scientific notation is especially

useful in situations whereby very large or very small number of measurements is encountered. This frequently happens in science, e.g. the number of oxygen atoms in a litre of air at room temperature and pressure is 9,900,000,000,000,000,000.

When you try to read these numbers, you find yourself counting the number of zeros to realize how large or how small the number is. Scientific notation replaces this cumbersome number by much more readable ones.

Scientific notation is the representation of a number in the form $A \times 10^n$, where A is a number with a single nonzero digit to the left of the decimal point, and n is a whole number. For example 510.3 litres of water in scientific notation is written as 5.103×10^2 litres.

Here 10^2 means, two factors of 10 that is $10^2 = 10 \times 10$. In other words 5.103×10^2 litres = $5.103 \times 10 \times 10$ litres = 510.3 litres

In scientific notation you would write the number of oxygen atoms in a litre of air as 9.9×10^{21} . It is much easier to read and write this number in scientific notation. The number n is called the exponent and 10^n the n th of 10. In the quantity 5.103×10^2 , the exponent is 2 and the power of 10 is 10^2 . The exponent can be positive as it is here or it can be negative. A negative exponent tells the number of times 1 is divided by 10. For example 10 raised to the exponent -2 is equal to 1 divided by 2 factor of 10 $10^{-2} = \frac{1}{10 \times 10}$

To write 1.10×10^{-2} metres in decimal form, you write 1.10×10^{-2} metres = $1.10 \times \frac{1}{10 \times 10}$ meters = 0.0110

Any number written in decimal form can be transformed to scientific notation by simply moving the decimal point to obtain a number between 1 and 9.99. After this, you should have non-zero digit to the left of the decimal point. Count the number of places you move the decimal point to the left or to the right. This gives the exponent in the scientific notation of the number. Let us try this with the number of oxygen atoms, in a litre of air, which we gave earlier on

$$9,900,000,000,000,000,000 \quad \begin{array}{l} \text{Places moved left} \\ \blacktriangledown \end{array} = 9.9 \times 10^{21}$$

Move the decimal point to the left until you have only one digit on its left. As you move the decimal point you count the number of digits that

you pass (21). This then becomes the exponent for the power of 10. The answer is 9.9×10^{21} .

The following example of conversion of numbers in decimal form to scientific notation

Example 1.3

Express the following numbers in scientific notation.

- (a) 945.2 (b) 0.000464
- (c) 7.51 (d) 80

Solution

a) You shift the decimal point or place to the left giving a number having only one nonzero digit to the left of the decimal point. Now multiply the number by 10^2

$$9.452 = 9.452 \times 10^2$$

b) Shift the decimal point 4 place to the right then multiply the result by 10^4

$$0.000464 = 4.64 \times 10^{-4}$$

c) The number is already between 1 and 9.99---you shift the decimal point 0 place getting 10^0 as your power of 10. Write the number as 7.51×10^0 or simply leave it as 7.51 since 10^0 equal 1

d) Shift the decimal point 1 place to the left $80 = 8.0 \times 10^1$

SELF ASSESSMENT EXERCISE 3

Write the following numbers in scientific notation.

- i) 0.005262
- ii) 0.06400
- iii) 9.03.00
- iv) 8003
- v) 0.606

$$0.000464 = 4.64 \times 10^{-4}$$

In converting number written in scientific notation to decimal form. You simply shift the decimal point the number of place given by the exponent in the power of 10. When the exponent is positive you shift the

decimal place to the right and when it is negative you shift the decimal place to the left e.g. 8.4×10^6 km shift the decimal point to the right.

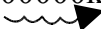
8.400000km

The result is 8,400,000km

The diameter of the red blood cell is about 8×10^{-9} m meter. To write this in decimal form you shift the decimal point to the left. 8.0×10^{-9} metre =

0.0 0 0 0 000 8 0 = 0.00000008.

The next example further illustrates how to convert a number written in scientific notation to the decimal form.

Example 1.4

Convert the following numbers in scientific notation to decimal form

- (a) 9.4×10^{-5} (b) 3.506×10^2

Hint

Shift the decimal point the number of places indicated by the exponent in the scientific notation (shift left if negative, shift right if positive).

Solution

- a) Shift the decimal point 5 place to the left (the exponent is -5)
 $9.4 \times 10^{-5} = 0.000094$

The answer is 0.000094

- b) Shift the decimal point 2 place to the right (the exponent is 2)
 $3.50.6$

The answer is 350.6

SELF ASSESSMENT EXERCISE 4

Convert the following numbers in scientific notation to decimal form

- i) 5.62×10^{-4}
 ii) 4.55×10^{-4}
 iii) 3.89×10^0

4.0 CONCLUSION

In this unit you have been exposed to the meaning of the concept measurement. You have equally been made to realize that the term measurement covers two main parts these are magnitude and unit. In the same vein you are to know that when measurements are made, the true value of a given quantity is being sought for. You have also learnt about how you can convert ordinary numbers to scientific notations and vice versa. Measurement is very important in modern society, especially in people's daily lives. Its importance can be seen when making calculations, balancing a checkbook or figuring out how much change they could get, in sport and science

5.0 SUMMARY

In this unit you have learnt that:

- Scientists use vast majority of numbers which come from measurement
- Measurement can be defined as the act of determining the size or amount of something.
- Measurement has two properties i.e. magnitude and unit.
- Certain terms are used in measurement. These include; accuracy and precision.
- Accuracy is degree of agreement between measured value and accepted true value of a quantity.
- Precision refers to the degree of agreement between individual measured values in a series of measurements and the average value.
- A set of measurements can have one of four possible combinations of accuracy and precision
- Measurements could be written in scientific notation.
- Scientific notation has to do with representing a number in the form $A \times 10^n$ where A is a number with a single non-zero digit to the left of the decimal point
- Numbers written in scientific notation can be converted to decimal form and vice versa.

6.0 TUTOR-MARKED ASSIGNMENT

1. Write the following numbers in scientific notation (a) 0.0069252 (b) 0.06300 (c) 820.00 (d) 6002 (e) 0.707
2. Convert the following numbers from scientific notation to decimal form (a) 4.834×10^4 (b) 6.256×10^3 (c) 4.89×10^2
3. Distinguish between accuracy and precision as they relate to measurement.

7.0 REFERENCE/FURTHER READINGS

Darrell D. E, Wentworth, B. J. D. (1995). *Introductory Chemistry*. U. S. A., Houghton Mifflin Company, 17-21.

Sevenair, J. P. and Burkett, A. R. (1997). *Introductory Chemistry* U. S. A. Win c Brown Communication 69-72.

Anyakoha, M. W. (2005). *New School Physics for Senior Secondary Schools*, Lagos. African First Publishers Ltd. 1-8.

UNIT 2 STANDARD UNITS OF MEASUREMENT

CONTENTS

- 1.0 Introduction
- 2.0 Objectives
- 3.0 Main Content
 - 3.1 S. I. Unit
 - 3.2 Conversion Factors
 - 3.3 Length
 - 3.4 Mass
 - 3.5 Time
 - 3.6 Difference between Mass and Weight
 - 3.7 Temperature, Volume and Density
 - 3.7.1 Comparison of Temperature Scale
 - 3.7.2 Volume
 - 3.7.3 Density
- 4.0 Conclusion
- 5.0 Summary
- 6.0 Tutor-Marked Assignment
- 7.0 References/Further Readings

1.0 INTRODUCTION

In your previous studies of science and mathematics, you must have come across such quantities as length, mass, time, angle, temperature, volume and a host of others. In this unit, you will learn more about these quantities and the standard way of measuring them.

2.0 OBJECTIVES

By the end of this unit, you should be able to:

- describe the roles of basic units and prefixes in the modern metric system (the international system or S. I)
- state the S. I units for measuring length, mass, and time
- differentiate between the mass and the weight of an object
- distinguish between temperature and heat
- define an absolute temperature scale
- define the Celsius temperature scale and give the freezing point and boiling point of water on this temperature scale
- define the Kelvin temperature scale and give the freezing point and boiling point of water on this scale
- show how the units of volume arise from the length measurements of the object
- define the litre in terms of cubic decimeter

- define milliliter in terms of cubic centimeter.

3.0 MAIN CONTENT

3.1 The International System or S. I. Units

The metric system is a system of units based on the decimal number system. The modern form of this system of units is called “the International system or S. I. unit. The system has 7 base units from which all other units are derived. Smaller and larger units are shown by writing base units with S. I. Prefixes to denote multiplication by powers of 10.

The S. I. base units are those S. I. units from which all others are derived. Table 2.1 lists the seven basic units, symbols and abbreviation used to represent them.

Table 2.1

Quantity	Unit	Symbol
Length	Metre	m
Mass	Kilogramme	kg
Time	Second	s
Temperature	Kelvin	K
Amount of substance	Mole	mol
Electric current	Ampere	A
Luminous intensity	Candela	cd
Plane angle	Radian	rad
Solid angle	Steradian	sr

The following are derived from the seven basic units.

Table 2:2

Quantity	Unit	Symbol
Area	Square metre	m ²
Volume	cubic metre	m ³
Velocity	metre per second	m/s or ms ⁻¹
Acceleration	metre per second squared	m/s ² or ms ⁻²
Density	Kilogram per cubic metre	Kg/m ³ or kgm ⁻³
Momentum	Kilograms metre per second	Kg m/s or kgm s ⁻¹
Force	Newton	N
Work, Energy	Joule	J (Nm)
Power	Watt	W (J/s or Js ⁻¹

Temperature	Degree Celsius	°C
Electric charge	Conlumb	C
Electric potential difference	Volt	V
Electric resistance	ohm	Ω
Electric capacitance	Farad	F
Magnctic flux	Weber	Wb
Magnetic flux density	Tesla	T
Inductance	Lumen	lm
Illumination	Lux	lx
Frequency	Hertz	Hz
Specific heat capacity	Joule per kilogram per Kelvin	J/kg/K or J kg ⁻¹ k ⁻¹
Moment of a force	Newton metre	Nm

One of the major advantages of the metric system is it is based on the decimal number system. In SI unit, a larger or smaller unit than the base unit is indicated by an S. I. prefix which is a prefix used in S. I. to indicate the power of 10. For example the basic unit of length is metre. If you want a smaller unit, you could use centimeter which is 10⁻² metre. The preffex centi means 10⁻² metre.

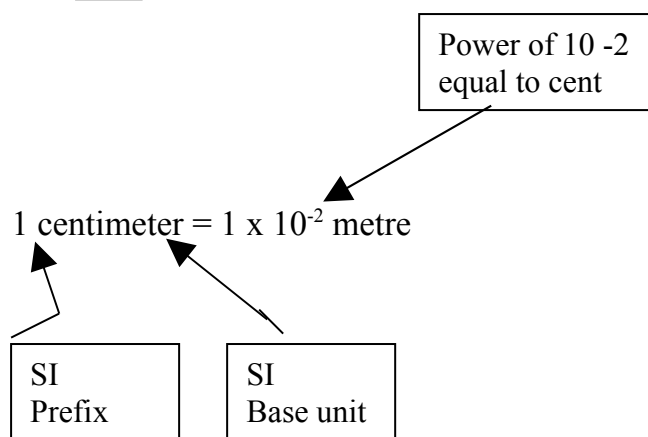

Table: 2.3 SI Prefixes

Multiples	Prefix	Symbol
10 ⁹	Giga	G
10 ⁶	Mega	M
10 ³	Kilo	K
10 ²	Hecto	H
10 ¹	Deca	Da
10 ⁻¹	Deci	D
10 ⁻²	Centi	C
10 ⁻³	Milli	M

10^{-6}	Micro	μ
10^{-9}	Nano	N
10^{-12}	Pico	p

3.2 Conversion Factors

$$1 \text{ atm} = 1.01325 \times 10^5 \text{ Nm}^{-2}$$

$$1 \text{ cal} = 4.184 \text{ J}$$

$$1 \text{ litre} = 1000 \text{ cm}^3 = 1 \text{ dm}^3$$

$$1 \text{ bar} = 10^5 \text{ Nm}^{-2} = 0.986923 \text{ atm}$$

Some Fundamental Constants

$$\text{Avogadro's Constant} = 6.022 \times 10^{23} \text{ mol}^{-1}$$

$$\text{Gas constant, } R = 8.314 \text{ Jmol}^{-1} \text{ K}^{-1}$$

$$\text{Faraday Constant, } F = 96485 \text{ Coulombs mol}^{-1}$$

$$\text{Boltzmann Constant, } R = 1.3807 \times 10^{-23} \text{ Jk}^{-1}$$

Example 2.1

1. a. By means of dimensional analysis, obtain a rough estimate of the electrical energy, E, if,

$$E = \frac{V^2 t}{R} \text{ given that } V = 2.85 \times 10^5 \text{ Kg}^{1/2} \text{ m}^{1/2} \text{ s}^{-1}$$

$$R$$

$$t = 18 \text{ secs.}$$

$$r = 1.58 \times 10^{-2} \text{ sm}^{-1}$$

- b. Express the value of E in mega Joule

Solution

$$\frac{V^2 t}{R} = \frac{(2.85 \times 10^5)^2 \times 18}{1.58 \times 10^{-2}}$$

$$= \frac{(3.0 \times 10^3) \times 2 \times 10^1}{2 \times 10^{-2}}$$

$$\frac{9 \times 10^6 \times 2 \times 10^1}{2 \times 10^{-2}}$$

$$= \frac{9 \times 10^7}{10^{-2}} = 9 \times 10^9$$

$$E = 10^{10}$$

Units $(\text{kg}^{1/2} \text{ m}^{1/2} \text{ s}^{-1})^2 \text{ s}$

$$s \text{ m}^{-1}$$

$$= \frac{\text{kgm s}^{-2}\text{s}}{\text{sm}^{-1}} = \text{kgm}^2\text{s}^{-2}$$

Energy (J) = Nm and Nerton, $N = \text{kg ms}^{-2}$

$$\text{Therefore, Energy } J = \text{kgms}^{-2} \times \text{m}$$

$$= \text{kg m}^2\text{s}^{-2}$$

Thus, $\text{kgm}^2\text{s}^{-2} = J$

b) The rough estimate = $10^{10}J$
 $10^6 J = 1\text{mJ}$.

$$\text{Therefore, } 10^{10}J = 10^{10} \text{ MJ}10^6$$

$$= 10^4 \text{ MJ}.$$

Note:

The figure obtained by this method is usually a rough estimate as required by the question, because there are many approximations made in the process of the calculation.

SELF ASSESSMENT EXERCISE 1

Calculate the approximate value of the frictional force of a falling spherical body by means of dimensional analysis. If

$$F = 6\pi r\eta v; \text{ given that, } \pi = 3.142$$

$$r = 4.97 \times 10^{-2}$$

$$\eta = 0.96\text{p (poise)}$$

$$v = 5.89 \times 10^{-2} \text{ cms}^{-1}$$

3.3 Length

The base units for measuring lengths and distances in the metric system are the meter. It equals about 39 inches, a little more than 3 feet. Large and smaller units of length and distances destinies are made by combining the meter with appropriate prefix. Scientists regularly use prefixes to indicted units of different sizes.

Here are some examples of how far scientists use prefixes to size units appropriately. Chemists and physicists use picometer ($\text{pm} = 10^{-12}\text{m}$) to measure sizes of atoms and molecules. An oxygen atom is about 140 pm in diameter. Biologists find the micrometer ($1\mu\text{m} = 10^{-6}\text{m}$) useful for measuring bacteria and other microorganisms. You can find millimeters

(1mm = 0.001m) and centimeters (1cm = 0.01m) on most rulers. The kilometer is about 0.6 of a mile.

Example 2.2

Which of the following measures closet to a centimeter?

- a) diameter of a one naira coin
- b) height of 5-year old child
- c) distance between cities.

Solution

The answer is (a)

SELF ASSESSMENT EXERCISE 2

Match each of the given sizes (left column) with the appropriate objects (right column)

Approximate size	object
2m	Length of a pencil
15m	Length of a fly
10mm	Height of a skyscraper
0.3km	Width of an automobile

3.4 Mass

The mass of an object is the quantity of matter in that object. Mass of an object is usually determined by weighing it on a balance. Mass is often confused with weight. Even scientists occasionally do it, in fact they still use the verb to weight when they mean to find the mass in almost all laboratory settings.

The basic unit for measuring the mass of an object is the gram. (Which is the mass of about 20 drops of water)? For many everyday applications, this unit of measurement is too small, so the kilogram (about 2.2 lb) is more widely used. Scientists use the milligram ($1\text{mg} = 10^{-3}\text{g}$) and the microgram ($1\mu\text{g} = 10^{-6}\text{g}$) where measuring masses of small samples. The metric ton is 1000^2kg (which is 10^6g) the metric ton is of commercial importance.

Example 2.3

Guess the mass of each of the following in conveniently sized metric units.

- a) A fly
- b) A bucket of water
- c) A strand of hair
- d) A 4-year old child

Solution

- a) 2g
- b) 20kg
- c) about 1mg (10-3g)
- d) about 20 kg

SELF ASSESSMENT EXERCISE 3

Guess the mass of each of the following in conveniently sized metric units.

- i) A paper clip
- ii) An automobile
- iii) A match box

3.5 Time

For scientists, the basic (SI) unit of time is second. They use the metric prefixes to make units to measure time spans shorter than a second, such as millisecond and microsecond. For longer time they usually revert to units such as minutes, hours, days, weeks and years. These units are not related to second by factor of 10.

3.6 Differences Between Mass and Weight

Mass and weight are often used interchangeably. However, the two mean different things. The differences between the two quantities are shown in the table below.

Mass	Weight
i. Quantity of matter in an object	The force exerted by gravity on an object
ii. Mass of object remains the same from place to place	Weights of objects vary depending on the area.
iii. Mass is measured in gramme	Weight is measured in newtons.

3.7 Temperature, Volume and Density

The temperature of an object is a measure of its hotness or coldness. At its most basic level, you can view temperature as a measure of the amount of motion of the atoms and molecules that make up an object. Objects at high temperatures have more molecular motion than they do at lower temperatures.

Temperature is measured by means of a thermometer. The common temperature scale in the United States is the Fahrenheit scale ($^{\circ}\text{F}$). The most commonly used scale throughout the world is the Celsius scale ($^{\circ}\text{C}$), and in most scientific work.

The Kelvin scale is the temperature scale used in the international system. An absolute temperature scale is one in which the lowest temperature is given the value zero. The Kelvin scale is an absolute temperature scale. As you shall see in a moment, it is slightly related to the Celsius scale.

3.7.1 Comparison of Temperature Scale

The three temperature scales are related to one another in the following ways:

- i) $^{\circ}\text{F} = (1.8)^{\circ}\text{C} + 32$
- ii) $\text{K} = ^{\circ}\text{C} + 273$

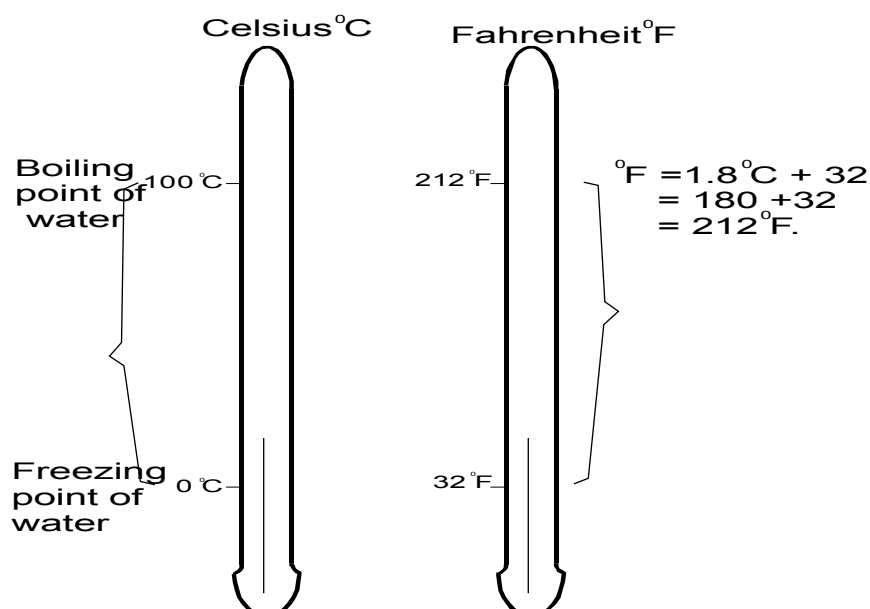

Example 2.4

Perform each of the following temperature conversion

- a) 60°F to Celsius degrees
- b) 40°C to Fahrenheit degrees.

Solution

$$\begin{aligned}
 60^{\circ} &= (1.8) (^{\circ}\text{C}) + 32 \\
 (1.8) (^{\circ}\text{C}) &= 60 - 32 \\
 (1.8) (^{\circ}\text{C}) &= 28 \\
 ^{\circ}\text{C} &= \frac{28}{1.8} \\
 ^{\circ}\text{C} &= 15.555 = 16^{\circ}\text{C}
 \end{aligned}$$

The Celsius temperature is approximately 16°C

$$\begin{aligned}
 \text{b) } 40^{\circ}\text{C} &= (1.8) 40^{\circ}\text{C} + 32 \\
 &= 72 + 32 = 104^{\circ}\text{F}
 \end{aligned}$$

The Fahrenheit temperature is 104°F

Example 2.5

Perform the following temperature conversions

- a) 20°C to Kelvin
- b) 25K to Celsius degree

Solution

$$\begin{aligned}
 \text{a) } &\text{Using the expression} \\
 \text{K} &= ^{\circ}\text{C} + 273 = 20 + 273 = 293\text{K}
 \end{aligned}$$

$$\begin{aligned}
 \text{b) } 25\text{K} &= ^{\circ}\text{C} + 273 \\
 25 - 273 &= ^{\circ}\text{C} = -248
 \end{aligned}$$

The answer is -248°C

SELF ASSESSMENT EXERCISE 4

1. Perform the following temperature conversions

- a) 100°C to Kelvin
- b) 20°k to Celsius degrees

2. Do the following conversions as appropriate

- a) 20°F to Celsius degrees
- b) 20°C to Fahrenheit degrees.

3.7.2 Volume

Volume **has** a decimal unit in the international system. The most familiar metric system unit of volume is the litre. (L). Volume has a derived unit that comes from meter; the basic unit of length. The derived unit of area is the square meter (m²) and that of volume is the cubic meter (m³). For practical reasons, the litre and milliliter. (mL) are the volume units used most frequently by scientists especially the chemists. Another units, which you will often see is the cubic centimeter (cc or cm³), which is exactly equal to the milliliter (1mL = 1cc = 1cm³). This unit is used extensively in medicine and biology. For instance, medical hypodermic syringes are usually graduated in cubic centimeters. Laboratory instruments used to determine the volume of liquids include, measuring cylinders, beakers, burettes, pipettes, volumetric flasks and conical flasks.

Figure 2.1

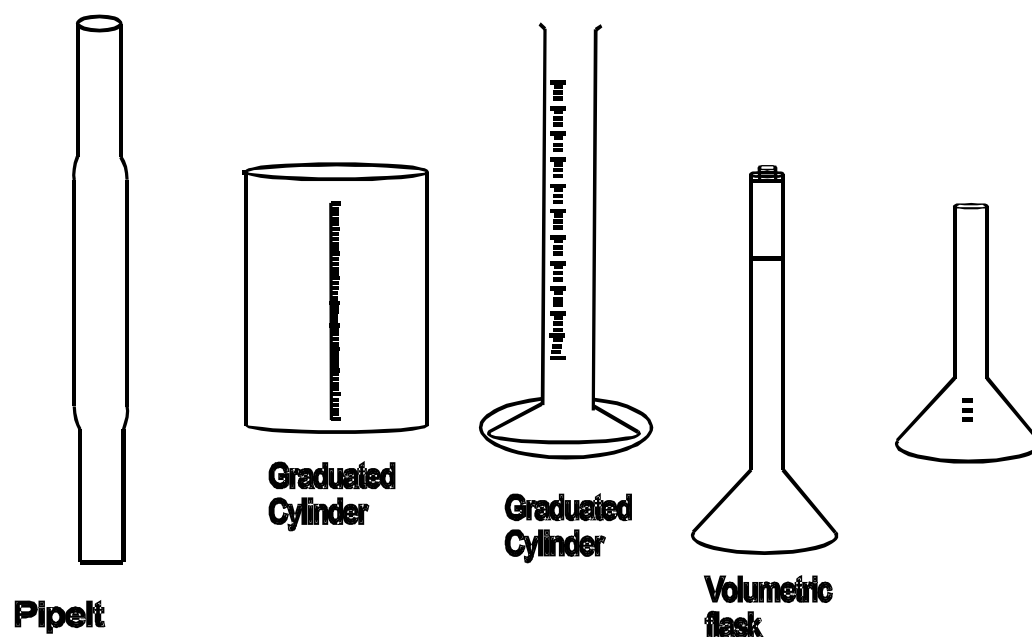

3.7.3 Density

Density is an intensive property of an object that is often used to help identify substances. The definition of density is

$$d = \frac{m}{v}$$

Where m is the mass (typically in grams), v is the volume (in Ml for solids and liquids in L for gases) and d is the density.

Example 2.6

1. What is the density in gm^{-1} of a piece of metal that has a volume of 25ml and a mass of 125g ?

Solution

$$d = \frac{m}{v} = \frac{125\text{g}}{25\text{ml}} = 50\text{gm}^{-1}$$

2. A chemist pours 30.0ml of water in a graduated cylinder and then submerged a 127g piece of metal in the water. The water level rose to 52.2ml . What is the density of the metal?

Solution

Final volume – initial volume

$$52.2\text{ml} - 30.0\text{ml} = 22.2\text{ml}$$

The density is then

$$d = \frac{m}{v} = \frac{127\text{g}}{22.2} = 572\text{g/ml} \text{ or } 592\text{gml}^{-1}$$

4.0 CONCLUSION

In this unit, you have learnt about standard units of measurement. You have also learnt the basic units and prefixes in the modern metric system. (That is, the international system (or S. I. unit) of measurement. You have also been exposed to the measurement of quantities such as length, mass, time, temperature and volume. The instrument for determining each of these quantities were also dealt with

5.0 SUMMARY

In this unit you have learnt that:

- The universally recognized system of measurement is the S. I. system
- The standard unit for measuring mass is kilogram, that of length is in meters, time is in seconds, temperature is degree Celsius or Kelvin while volume is measured in cubic centimeter.
- The Celsius, Kelvin and Fahrenheit scales are inter convertible
- Temperature differs from heat because they are measured in different units.

6.0 TUTOR-MARKED ASSIGNMENT

1. What do you mean by S. I. Unit?
2. Mention the seven base quantities, stating their units and symbols.
3. State the standard unit for measuring the following quantities.
(i) Volume, (ii) time (iii) Temperature (iv) mass

7.0 REFERENCES/FURTHER READINGS

Adeboye, J. O. (1987). *Application of Mathematics to Chemistry*. Oyo, Oyo State College of Education. Unpublished Memeograph, 1-15.

Darrel, D. E. Wentworth, J. D. (1995). *Introductory Chemistry*. USA: Houghton Mifflin Company, 12-16.

UNIT 3 SIGNIFICANT FIGURES

CONTENTS

- 1.0 Introduction
- 2.0 Objectives
- 3.0 Main Content
 - 3.1 Significant Figures and Uncertainty in Measurement
 - 3.2 Counting Significant Figures
 - 3.2.1 Rules for Counting Significant Figures
 - 3.3 Exact Numbers
 - 3.4 Significant Figures in Arithmetic Results
 - 3.4.1 Rules for Significant Figures in Calculations
 - 3.5 Rounding of Numbers
 - 3.5.1 Rules for Rounding
- 4.0 Conclusion
- 5.0 Summary
- 6.0 Tutor-Marked Assignment
- 7.0 References/Further Readings

1.0 INTRODUCTION

Variations often occur when measurements are taken in science or mathematical activities. For instance the difference in quoting the magnitude of gravitational field strength as 9.8Nkg^{-1} or 9.8Nkg^{-1} . In the first case, we are saying that, the gravitational field strength is closer to 9.8Nkg^{-1} than to 9.7Nkg^{-1} or 9.9Nkg^{-1} (i.e. it is within 0.05Nkg^{-1} or 9.8Nkg^{-1}) in the second the claim is much tighter – within 0.005Nkg^{-1} of 9.81Nkg^{-1} (that is, close to 9.81Nkg^{-1} then to 9.80Nkg^{-1} or 9.82Nkg^{-1} . such variations in measurement readings is quite normal and all measurements exhibit such variations. They are the result of limitation making any measurement. In this unit therefore, you will learn about why all measurements have some uncertainty then. You will also be exposed to the use of significant figures to report the uncertainty in them measured numbers.

2.0 OBJECTIVES

At the end of this unit, students should be able to:

- explain why all measurements have some uncertainty in them
- count the number of significant figures in measured numbers
- differentiate between exact numbers and measured numbers
- solve simple problems involving the use of significant figures
- use the rules for obtaining significant figures in an arithmetic.

3.0 MAIN CONTENT

3.1 Significant Figures and Uncertainty in Measurement

Let us now explore in brief, the idea of uncertainty in measurement. For example; if the volume of a liquid is measured using a graduated cylinder, where the result is 32.6cm^3 . Then to 32cm^3 the first value (i.e. 32) of this measured number is certain: the last digit however, is uncertain. If you tell anybody who is familiar with measurement, that the volume of a liquid is 32.6cm^3 that person would understand that the last digit (6) has some uncertainty in it and that the volume of liquid is probably somewhat between 32.5cm^3 and 32.7cm^3 .

Supposing this volume had been reported as 33cm^3 (i.e. its volume to the nearest milliliters someone reading your report would conclude that the volume lies somewhere between 32cm^3 and 34cm^3 . This indicates that the number of digits of figures used in reporting a measurement is important. Hence, we would say that, all of the digits in 32.6cm^3 are significant in the sense that all three are needed to convey the best value of the volume being measured. When measured numbers are written; significant only figure (or digits) should be given, less. ‘Significant figures’ are those digits in a measured number (or in the result of calculations with measured numbers) that include all certain digits plus a final one that is somewhat uncertain. The last digit that has some elements of uncertainty in it is called the least significant digit. In the above example of measured volume, the least significant digit is 6.

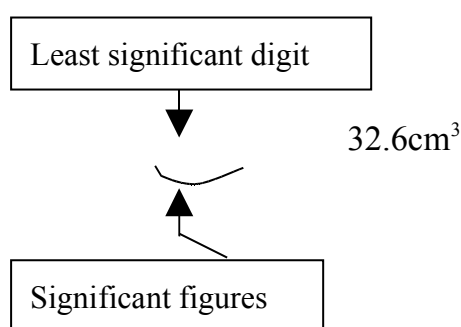

By convention, it would be incorrect to report the above measured volume as 32.60cm^3 , as this would indicate that the uncertainty in the measured volume occurs in the last digit which is 0. In other words, the volume has in between 32.59cm^3 and 36.61cm^3

3.2 Counting Significant Figures

In order to write significant figures correctly, it is important to understand how to count the number of significant figures or significant

digits in a measured value. As you will see shortly, this is most important in working with significant figures in calculations. The value 32.6 has 3 significant figures, which you obtain simply by counting all the digits. However, some numbers contain zeros and zeros are not always significant digits. For instance, let us consider the number 0.0326. The first zero is written to draw attention to the decimal point, it is not a significant figure. This zero could be omitted (though it is preferable to include it). The zero just to the right of the decimal point is also not a significant figure. The easiest way to understand this is to write the number in scientific notation, which is 3.26×10^{-2} . The main purpose of the zero was to tell about the correct decimal magnitude of the number (the correct power of 10). The number 0.0326 has three significant figures.

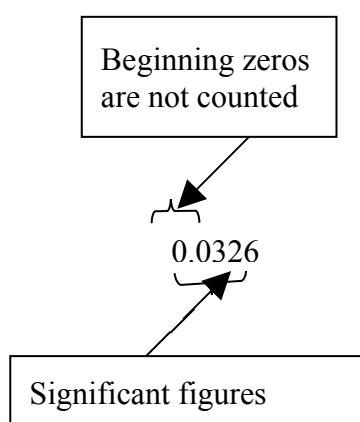

What is the status of the zero at the end of the measured number 0.03262? ordinarily, the end zero is the least significant figure. Its purpose is to convey the correct range of uncertainty in the measured number. Thus, whenever an end zero is at the right of the decimal point, you can be sure that, it is a significant figure. Hence, the number 0.03260 has four significant figures.

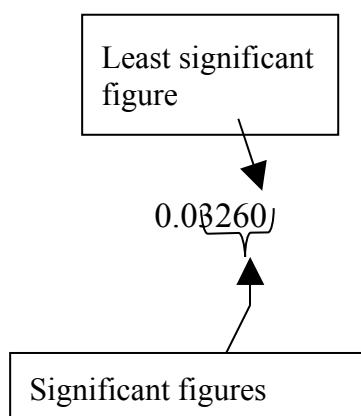

Sometimes, the purpose of a zero is not clear. For instance, consider the statement “the distance between the earth and the sun is 93,000,000 miles. Does this mean 9.3×10^7 miles (in which we have two significant figures) or does it mean 9.3000000×10^7 miles (in which we have eight significant figures)? The answer depends on the purpose of the zeros. Thus, the writer of the number should seek clarification regarding whether they are written to convey the correct magnitude of the number or written to convey the correct uncertainty in the measurement.

Scientific notation is often the best way to write a number to indicate an intention about which digits are significant. The number 9.3×10^7 has two significant digits in it. In certain situations, one may find it useful to add a decimal point as a way of saying that the zeros are significant. For example, if you write 50°C (not the decimal point), you will be saying that the temperature has two significant figures.

3.2.1 Rules for Counting Significant Figures

The following rules for counting significant figures in number summaries what we have just discussed.

- i) All digits are significant except zeros at the beginning of a number and possibly zeros at the end of a number (each of the numbers 4.46, 3.05 and 0.446 has three significant figures).
- ii) End zeros are significant if the number contains a decimal point (Each of the numbers of 3600 and 3.500 has four significant figures)
- iii) End zeros may or may not be significant if the number has no decimal point. Either rewrite the number in scientific notation to clarify the number of significant figures intended or if appropriate add a decimal point.
- iv) Terminal zeros ending to the left of the decimal point may or may not be significant (Each of the numbers 0.0054 and 200.002 has 2 two and six significant figures respectively)
- v) For numbers that do not contain decimal points, thus 900cm may have one significant figure (i.e. digit 9) two significant figures (i.e. 90) or three significant figures (900). Any uncertainty can be removed by expressing the measurement in scientific notation where a number is written in the form $A \times 10^n$ (see unit 1.5)

The following example illustrates the application of these rules.

Example 3.1

Count the number of significant figures in each of the given numbers.

- a) A steel rod is measured and reported to be 11.08cm long
- b) A computer report the time it takes to calculate the class average at 3.160 seconds.
- c) The volume of solution in a bottle is found to be 2.90ml.
- d) The distance between two points is found to be 7800m

Solution

- a) Count all digits, including the zeros, since they are neither beginning zeros or end zeros. There are four significant figures (rule 1)
- b) Count all digits including the end zero because the number contains a decimal point (there are four significant figures (rule 2)
- c) Count all digits including the end zero because the number contains a decimal point. There are three significant figures. (rule 2)
- d) It is not clear how many, if any of the zeros are significant, without more information (rule 3) if the number has three significant figures you could make this clear by writing it as $7.80 \times 10^3\text{m}$. You count all digits in 6.80 as significant.

SELF ASSESSMENT EXERCISE 1

How many significant figures are there in each of the following quantities?

- (a) 16.06 ml (b) 69.00m (c) 30.200

3.3 Exact Numbers

We have so far, discussed measured numbers. In the next section we will describe numbers that result from calculating with measured numbers. All of these numbers have some uncertainty associated with them. You would also encounter exact numbers, which arise when one counts items or when one defines certain units. For example, if the length of a desk is found to be 8m, it means exactly 8 not 7.9 or 8.1.

Also, when it is said that there are 12 inches in a foot, it means exactly 12.

When exact numbers are written the conventions in significant figures are not applied to such situations. Exact numbers are written with the understanding that they are exact, these then means that there is no uncertainty in an exact number.

3.4 Significant Figures in Arithmetic Results

When measurements have been made, the tendency might be to do calculations with them. For example if you want to find the floor area of a room; you first measure the length and width of the room, then you multiply the length by the width to find the area if the length of the room is 7.5 and the width is 8.5m in giving these measurements to two significant figures you are saying that you know the first digit with certainty, but feel the second digit has some uncertainty in it. To find the area, you multiply the length by the width on your calculator, the calculator result is 62.75

$$\text{Area} = 7.5\text{m} \times 8.5\text{m} = 62.75\text{m}^2$$

You can not write the answer as the calculator result because of the uncertainty involved in the value.

Generally, because measured values have uncertainties in them, the result of a calculation with the numbers has an uncertainty. This uncertainty is expressed by writing the results to the proper number of significant figures. There are rules guiding this decision. These are given in the next section of our discussion.

3.4.1 Rules For Significant Figures In Calculations

There are two rules for deciding the number of significant figures in the result of calculation one for the multiplication or division of numbers and one for the addition or subtraction of numbers. These rules are given below.

- i) When multiplying or dividing quantities give as many significant figures in the answer as there are in the quantity with the fewer number of significant figures.
- ii) When adding or subtracting quantities, give the same number of decimal places in the number as there are in the quantity with the fewer number of decimal places.

To illustrate the first rule, consider the following calculations.

$$5.7\underline{1}\text{m} \times 7.\underline{9}\text{m} = ?$$

The quantities have been written with the proper number of significant figures. The digit with some uncertainty (least significant digit) is underlined. These uncertainties will affect the answer, and according to rule the quantity with the fewer number of significant figures (7.9m) limits the number of significant figures in the answer (to two).

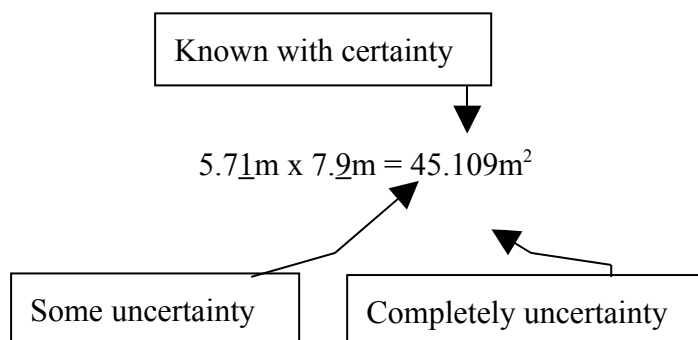

The digits to the left are known with certainty, digits to the right are completely uncertain (non-significant). There should be two significant figures in the answer.

$$5.\underline{7}1\text{m} \times 7.9\text{m} = 45\text{m}^2$$

To illustrate rule 2 lets add 2 masses 296.2g and 3.246g we have,

$$\begin{array}{r} 296.\underline{2}\text{g} \\ \underline{3.246}\text{g} \\ \hline 299.\underline{446}\text{g} \end{array}$$

There are uncertainties in the two masses, which we added, especially in their last digits. Digits farther to the right are uncertain. Applying rule 2, the answer should be written as 2.99.45

3.5 Rounding of Numbers

Results of calculations as may be displayed on the screen of a calculator may have more digits that are warranted by the rules for significant figures. In such situations, there is need to reduce the calculator result to the correct significant figures. The procedure for doing this is known as rounding. Thus, rounding is the procedure of dropping non significant digit in a calculation result and perhaps adjusting the last remaining digit upward. Suppose a room is 7.5m long and 4.8m wide. The area of the room is

$$7.5\text{m} \times 4.8\text{m} = 36.556\text{m}^2$$

Of the quantities on the left, the first one ($7.\underline{6}\text{m}$) has the fewer number of significant figures (two) and so limits the number of significant figures in the result. In the answer we have underlined the second digit ($3\underline{6}.556\text{m}^2$) in which we expect some uncertainty. The digits to the right of this digit are non-significant hence they are dropped, on rounding. But there is still need to determine if necessary to increase the rightmost digit is retained.



36.556m^2

To determine, if this digit needs to be increased, the following rules are considered.

3.5.1 Rules for Rounding

- i) If the first digit to be dropped is less than 5 leave the preceding digit as it is
- ii) If the first digit to be dropped is 5 or greater increase the preceding digit by 1
- iii) Look at the leftmost digit to be dropped.

From rule (ii), you can see that the number 36.556 rounds to 37 (the first digit to be dropped is 6 which is greater than 5). The following examples further illustrate the use of significant figures when doing calculations and rounding.

Example 3.2

Perform the following arithmetic and give the answer to the correct number of significant figures.

- a) $14.942 + 88.1$ (b) $14.9 - 6.74$ (c) 8.925×2.5 (d) $8.924 \times 2.3 =$
Solution

- (a) $14.94\underline{2} + 88.\underline{1} = 103.042$ (rounds to 103.0)
 (b) $14.\underline{9} - 6.7\underline{4} = 8.\underline{1}6$ (rounds to 8.2)
 (c) $8.92\underline{5} \times 2.\underline{5} = 22.3125$ (rounds to 22)
 (d) $8.92\underline{4} : 2.\underline{5} = 3.\underline{5}696$ (rounds to 3.6)

SELF ASSESSMENT EXERCISE 2

Carry out the following arithmetic and report the answers to the correct number of significant figures

- i) $34.1 + 62.08$
- ii) $112.36 - 84.1$
- iii) 8.92×3.456
- iv) $11.54 - 3.6$
- v) $4.58 + 12.64$

4.0 CONCLUSION

It is evident from our discussion of this unit that variations do occur when measurements of the same quantity are taken. It has also been shown that these noticeable variations usually impose certain limitations on the result of measurements. In the final analysis you were treated to why these uncertainties occur and the use of significant figures in reducing those limitations.

5.0 SUMMARY

In this unit you have learnt that:

- Variations do occur in mathematical and scientific measurements.
- These variations impose some limitations on the results of measurements.
- It often brings about some uncertainty in measurements.
- Significant figures are those digits in a measured number that include all certain digits plus the final one that is somewhat certain.
- The use of scientific notation is the best way to write a number to indicate which digits are significant and which are not significant.
- Certain rules guide the counting and use of significant figure in calculations.
- Exact numbers are written with the understanding that they are exact.
- That in exact numbers, there exist numbers, there exist no uncertainty
- Rounding of number is necessary in order to present result in a more precise form.
- Rounding involves dropping of non significant digits in a calculation result and perhaps adjusting the last remaining digit upward.
- Certain rules guide the procedure for rounding of numbers.

6.0 TUTOR-MARKED ASSIGNMENT

1. Define (a) significant figures (b) rounding of numbers.
2. Mention any five rules guiding the counting of significant figures
3. Perform the following calculations and round off the answers to the correct number of significant figures.

- a) 2.568×5.8 (b) $5.41 - 0.398$
c) $(4.18 - 58.16) \times (3.38 - 3.0)$

7.0 REFERENCES/FURTHER READINGS

- Adeboye J. O. (1987). *Application of Mathematics to Chemistry*. Oyo, Oyo State college of Education Unpublished mimeograph, 18-20.
- Darrel, D. E. and Wentworth J. D. (1995). *Introductory Chemistry*. USA, Houghton Milton Company, 36-40.
- Raimi, S. M., Bolaji, O. S., Oyediran. A. M. and Agoro, A. A. (2003). *Basic Mathematics for Science Students*. Oyo. City Publishers, 150-154.
- Olajire, A. A. and Ayodele, E. T. (1999). *Introductory Physical Chemistry*. (University Series A); Ibadan, Ogfat Publications, 20-24.
- Steve, A. and Jonathan, A. (2000). *Advanced Physics*. U. K. Oxford University Press, 31.

UNIT 4 UNIT CONVERSION AND CALCULATIONS

CONTENTS

- 1.0 Introduction
- 2.0 Objectives
- 3.0 Main Content
 - 3.1 Problem Solving and Dimensional Analysis
 - 3.1.1 Steps for Converting Units by Dimensional Analysis
 - 3.2 Conversion of Units
 - 3.2.1 Conversion from One Metric Unit to Another
 - 3.2.2 Conversion between Metric Units (Multistep Conversion)
 - 3.3 Conversion between any Two
 - 3.4 Changing Temperature Scales
 - 3.4.1 Relating Kelvin and Celsius Scales
 - 3.5 Relating Celsius and Fahrenheit scales
- 4.0 Conclusion
- 5.0 Summary
- 6.0 Tutor-Marked Assignment
- 7.0 References/Further Readings

1.0 INTRODUCTION

Many of the problems that you will come across in science and mathematics exercises involve change from one unit to another. This type of problem in fact, is one you often see in everyday situations. You will recall that in unit 2, units of measurements were extensively discussed. In this unit, procedures involved in the conversion of one unit of measurement to another shall be dealt with. Dimensional analysis, which is a general method of solving problem, which belongs to this category, will also be given attention.

2.0 OBJECTIVES

At the end of this unit, students should be able to:

- define dimensional analysis
- write an equivalence statement relating a given unit to a desired unit
- define conversion factor
- write a conversion factor, given the relationship between two units
- convert a quantity from one unit to another knowing the conversion factor
- convert from one metric unit to another.

3.0 MAIN CONTENT

3.1 Problem Solving and Dimensional Analysis

When scientists are confronted with problems whose solution appears obvious, arriving at a solution may not pose much problem. This is not the situation with more complex problems. The approach to these kinds of problems requires breaking down of such problems down into simpler problems or questions. For example, how many glasses of beer will you need for a party of 12 people, if each of the invited guests would drink three glasses of beer. Then knowing the glasses of beer needed, the next question is how many bottles of beer you should buy, if each bottle contains four glasses.

Mentally, the answers to this problem appear obvious but let's look at the problem using dimensional analysis because the approach can be used to solve problems whose solutions may not be so obvious. Dimensional analysis is a general problem solving technique in which one used the units of quantities to help one decides how to set up the problem.

In order to answer the first question use the number of persons at the party to calculate or convert to the number of glasses needed.

12 persons calculate or glasses of beer
 Convert \blacktriangleright

Secondly look for information in the problem that you can apply to relate number of persons to glasses of beer. The required information is: each person drinks three glasses of beer. This can be written as equivalences.

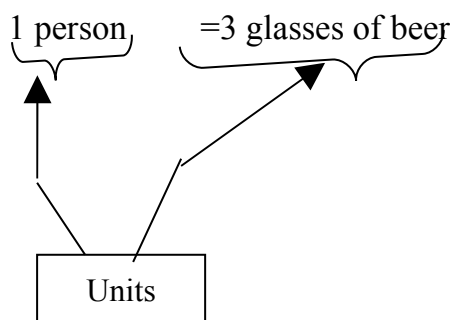

Labels associated with numbers in such equivalence shall be treated as units. Suppose both rules of this equivalence is divided by 3 glasses:

$$\frac{1 \text{ person}}{3 \text{ glasses of beer}} = \frac{3 \text{ glasses of beer}}{3 \text{ glasses of beer}} = 1$$

So if the factor $1 \text{ person}/3 \text{ glasses of beer} = 1$ then the factor $3 \text{ glasses of beer}/\text{person}$ also equals to 1, thus, the following 2 factors equal to exactly 1

$$\frac{1 \text{ person}}{3 \text{ glasses of beer}} \quad \text{and} \quad \frac{3 \text{ glasses of beer}}{1 \text{ person}}$$

One can multiply any quantity by these factors without changing its value.

These factors can function, as conversion factors. Conversion factor is a factor equal to 1 that converts a quantity in one unit to the same quantity in another unit. Take the quantity 12 persons and multiply it by the second of this conversion factor.

$$12 \text{ persons} \times \frac{3 \text{ glasses of beer}}{1 \text{ person}} = 36 \text{ glasses of beer}$$

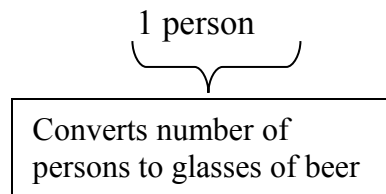

Here, the first part of the problem is solved i.e. obtaining the number of glasses of beer.

3.3.1 Steps for Converting Units by Dimensional Analysis

The following steps give a summary of the approach to problem solving by dimensional analysis:

- (i) Write out the desired conversion from the problem statement, note the given unit and the desired unit. You want to convert as follows: Quantity expressed in given unit convert to quantity expressed in desired unit.
- (ii) Obtain the conversion factor, write the equivalent statement, then the conversion factor for the conversion from given unit to desired unit. You write the conversion factor as a ratio with the given unit in the denominator and the desired unit in the numerator. The conversion factor will be a number, or factor multiplied by a ratio of unit

$$\text{Conversion factor} = \text{factor} \times \frac{\text{desired unit}}{\text{given unit}}$$

- (iii) Perform the conversion calculation. Multiply the quantity in the given unit by the conversion factor.

$$\text{Quantity in given unit} \times \text{factor} \times \frac{\text{desired unit}}{\text{given unit}} = \text{quantity in desired unit}$$

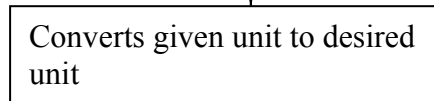

Let's now try the second part of the question; following the above steps. Knowing the glasses of beer needed (36); calculate the bottles of beer to be bought. Thus the conversion factor needed:

36 glasses of beer converts to Bottles of beer

Remember that each bottle contains four glasses. Then write the following equivalence statement.

1 bottle of beer = 4 glasses of beer.

The conversion factor from glasses of beer to bottles is

$$\frac{1 \text{ bottle of beer}}{4 \text{ glasses of beer}}$$

Therefore, $\frac{1 \text{ bottle of beer}}{4 \text{ glasses of beer}} = 9 \text{ bottles of beer}$

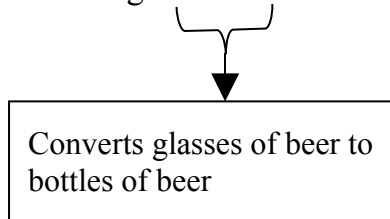

Thus, the party of 12 persons will require 9 bottles of beer figure 4.1 shows the idea for the problem that we have just solved.

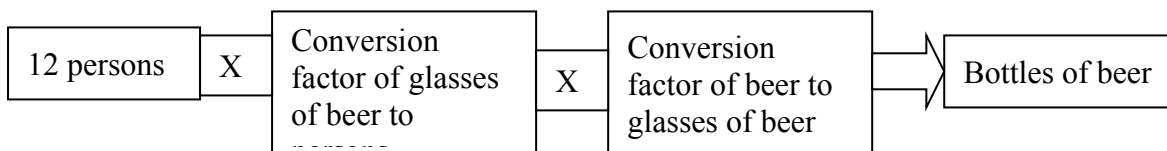

Fig. 4.1

The calculations for the problems, in brief or at a glance are as follows:

$$12 \text{ persons} \times \frac{3 \text{ glasses of beer}}{1 \text{ person}} \times \frac{1 \text{ bottle of beer}}{4 \text{ glasses of beer}} = 9 \text{ bottles of beer}$$

3.2 Conversion of Units

In the previous section, we discussed on how to use dimensional analysis and conversion factor to change from one unit to another.

Three basic steps were followed to accomplish this change viz.

- (1) Write out the desired conversion
- (2) Obtain the conversion factor and
- (3) Perform the conversion calculation.

One of the most important types of conversion is from one metric unit to another. Let's now take a look at this type of conversion.

3.2.1 Conversion from One Metric Unit to Another

Example 4.1

Let's consider the problem

How many milligrams are there in 7.71g?

There we are trying to change from a metric unit having no prefix to a corresponding unit with a prefix.

The desired conversion (step 1) is

7.71g converts to mg.

Now we need to obtain the conversion factor (step 2): what is the relationship between grams and milligrams. Recall that milli-is the prefix meaning 10^{-3} . This can be used to write an equivalent statement relating grams to milligrams.

$$1\text{mg} = 10^{-3}\text{g}$$

The factor that converts grams to milligrams is

$$\frac{1\text{mg}}{10^{-3}\text{g}}$$

(converts to g)

In the final analysis, we perform the conversion calculation (step 3) by multiplying what is given (7.71g) by the conversion factor.

$$7.71\text{g} \times \frac{1\text{mg}}{10^{-3}\text{g}} = 7.71 \times 10^{-3} \text{mg}$$

10⁻³



Converts of to mg

It should be noted that, the factor 10^{-3} at the bottom (left hand side) can be brought to the top as 10^3 which gives the answer 7.71×10^3 mg.

Example 4.2

- The straight line distance from a town A in the south West Nigeria and a town B in Benue State also in Nigeria is 2.98×10^5 m. How far is the town in kilometers?
- The volume of water in a household water rervoir is 1.35×10^{24} ml. (also written as cm^3). Calculate its volume in litres.

Solution

- The desired conversion is,
 2.98×10^5 m converts to km

Note that,

$$1\text{km} = 10^3\text{m}$$

Therefore, the conversion factor from meters to kilometer is

$$\frac{1\text{km}}{10^3\text{m}}$$

Also note that, the given unit is at the bottom, and the desired unit is at the top the calculation is 2.98×10^5 m.

Also note that, the given unit is at the bottom, and the desired unit is at the top. The calculation is

$$2.98 \times 10^5\text{m} \times \frac{1\text{km}}{10^3\text{m}} = 2.98 \times 10^2 \text{ km}$$

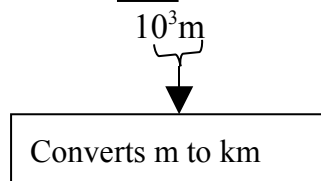

The correct power of 10 is obtained by subtracting 3 from 5 (i.e $5-3=2$); giving the power of 10 in the answer as 2

- The conversion desired is
 $1.35 \times 10^{24}\text{cm}^3$ converts to litres.

One way to solve this problem is simply to replace the prefix milli-with multiplication by 10^{-3}

$$1.35 \times 10^{24} \text{ml} = 1.35 \times 10^{24} \times 10^{-3} \text{L} = 1.35 \times 10^{21} \text{L}$$

This problem can also be solved by means of dimensional analysis.

You should note that conversion factor from milliliters to litres is

$$\frac{10^{-3}}{1 \text{ml}}$$

Thus, by dimensional analysis

$$1.35 \times 10^{24} \text{L} \times \frac{10^{-3} \text{L}}{1 \text{mL}} = 1.35 \times 10^{24+(-3)} = 1.35 \times 10^{21} \text{L}$$

SELF ASSESSMENT EXERCISE 1

Convert the following:

- (a) 2.58g to kg (b) 55.4cm to m (c) 8.11L to mL

3.2.2 Conversion Between Metric Units (Multistep Conversion)

A very useful type of metric conversion is one in which both the given and desired unit have prefixes in them. The problem then is a multistep conversion. The first step is to convert from a unit with the given prefix and the second step is to convert this result to the metric unit with the desired prefix. By breaking the problem into three steps, you can use both the given and desired to write the conversion factors. The method is similar to that in the previous section. For instance, if the mass of a chemical sample to be analysed in the laboratory is 265mg what is the mass of the sample in kilogram. The desired conversion is

$$265 \text{mg} \xrightarrow{\text{convert to g}} \text{g} \quad \& \quad \text{g} \xrightarrow{\text{converts to kg}} \text{kg}$$

The conversion factors needed are:

$$\frac{10^{-3} \text{g}}{1 \text{mg}} \text{ of and } \frac{1 \text{kg}}{10^3 \text{g}}$$

Note that you obtain each conversion factor by using the definition of the prefix. In each conversion factor, the unit from the preceding factor is at the bottom, the calculation is

$$\frac{10^{-3}}{1 \text{mg}} \times \frac{1 \text{kg}}{10^3} \times 265 = 265 \times 10^{-6} \text{kg} = 2.65 \times 10^{-4} \text{kg}$$

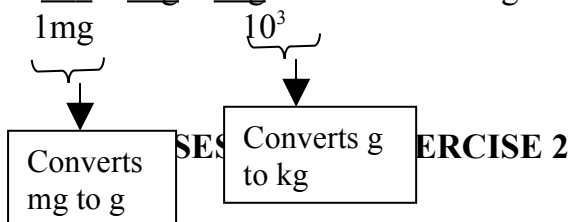

Do the following conversions:

1. 2.45 kg to mg
2. 99.6 cm to km

3.3 Conversion Between any Two Units

In the last section of this unit, we discussed conversion within the same units. In this section we are going to see how conversion could be accomplished between two units. This is because it is possible to do conversion between any two units following the steps used in the previously discussed conversion. The thing that must be borne in mind is the conversion factor (or the equivalent statement relating them. The moment this is known, the desired conversion between the two units in question becomes so easy to carryout for instance you have a steel rod measuring 5.614 inches in length and you would like to express this length in centimeters. The conversion you want is,

in $\xrightarrow{\text{convert to}}$ cm

To be able to do this, you need to know how inches and centimeters are related. Table 4.1 expresses this relationship. The U. S. unit is actually defined to be exactly 2.54cm.

The conversion factors from inches to centimeters is

$$\frac{2.54\text{cm}}{1 \text{ in}}$$

The Calculation is

$$\begin{aligned} 5.614\text{in} \times 2.54\text{cm} &= 5.614 \times 2.54\text{cm} \\ &= 14.25956\text{cm} \\ 14.25956 &\text{ rounds up to } 14.26 \end{aligned}$$

The significant figures are limited by those in the given quantity (5.614cm), 2.54cm in an exact quantity and does not limit the number of significant figures. The calculation reveals that, 5.614 in equals to 14.26cm.

Table 4.1 Relationship between Some Metric Systems/Units

Lengths	Mass	Volume
1 in = 2.54 cm (exact)	1lb = 0.4536kg	1qt = 0.9464L
1yd = 0.9144m (exact)	1lb = 16oz (exact)	4qt = 1 gal (exact)
1mi = 1.609km	1oz = 28.35g	
1mi = 5280 ft (exact)		

Source: Darrel, D. E. et al (1995), 56

Example 4.3

If a piece of rod weighs 146lb. what is this mass in kilogram?

Solution

Table 4.1 shows that 1lb = 0.4536kg
 The desired conversion is

$$146\text{lb} \xrightarrow{\text{converts to}} \text{kg}$$

The conversion factor from equivalent statement [(1 lb = 0.4536kg)] it is

$$\frac{0.4536\text{kg}}{1\text{lb}}$$

$$146\text{ lb} \times \frac{0.4536}{1\text{lb}} = 146 \times 0.4536$$

$$1\text{lb} = 66.226\text{kg}$$

SELF ASSESSMENT EXERCISE 4

A car weighs 645 lb what is the mass of this car in kilograms?

Sometimes, there may be need to do multiple conversion to convert a quantity in one unit to another unit. For example you measure the length of field and find it to be 455yd. You want to know the length of the field in kilometers. The desired conversion is

$$455\text{yd} \xrightarrow{\text{convert to}} \text{km}$$

From table 4.2, 1 yd = 0.9144m

The next step is to convert from yards to metres, then to kilometers.

This can be done as long as you know the meaning of the prefix kilo

$$455\text{yd} \xrightarrow{\text{convert to}} \text{m} \xrightarrow{\text{convert to}} \text{km}$$

To convert from yd to m, the following equivalence statement is relevant

$$1\text{yd} = 0.9144\text{m}$$

Also since kilo means 10^3m

$$1\text{km} = 10^3\text{m}$$

The conversion factors are:

$$\frac{0.9144 \text{ and } 1\text{km}}{1\text{yd} \quad 10^3\text{m}}$$

Now write down the conversion calculation:

$$\begin{aligned} & 455 \times \frac{0.9144}{1\text{yd}} \times \frac{1\text{km}}{10^3\text{m}} \\ & = 455 \times 0.9144 \times 1 \text{ km} \\ & = 0.4160520\text{km rounds to } 0.416\text{km} \end{aligned}$$

3.4 Changing Temperature Scales

In this section, we will see how to change a temperature given on one scale to an equivalent temperature on another scale. Of special importance is the change between the Celsius scale and the Kelvin scale.

3.4.1 Relating Kelvin and Celsius Scales

The Kelvin and Celsius scales are related by the following expression.

$$K = {}^{\circ}\text{C} + 273$$

Therefore, if you are given in Celsius, you change it to Kelvin by adding 273 to it in order to convert Kelvin to Celsius we use

$$\begin{aligned} K - 273 &= {}^{\circ}\text{C} \\ {}^{\circ}\text{C} &= K - 273. \end{aligned}$$

Example 4.4

- Ethanol boils at 78°C under normal atmospheric pressure express this boiling point on the Kelvin scale
- Liquid oxygen used in rocket engines boils at 90k under normal atmospheric pressure. Express this boiling point on the Celsius scale.

Solution

- Substitute 78 for ${}^{\circ}\text{C}$ into the main equation

$$K = ^\circ C + 273 = 78 + 273 = 351$$

Therefore ethanol boils at 351K.

- b) Start with the expression,

$$K = [^\circ C + 273]$$

Then rearrange the equation to

$$K - 273 = ^\circ C \text{ or } ^\circ C = k - 273$$

Now substitute 90, for K in the equation

$$^\circ C = k - 273 = 90 - 273 = -183$$

Hence, liquid oxygen boils at - 183^oC

SELF ASSESSMENT EXERCISE 4

The temperature of a heated iron rod was 296k. What was the temperature in degree Celsius?

3.5 Relating Celsius and Fahrenheit Scales

The relationship between the Celsius and Fahrenheit scales could be obtained by considering the freezing point and boiling point of water on these two scales. On the Fahrenheit scale, water freezes at 32^of and boils at 212^oF, a difference of 180^o. On the Celsius scale, water freezes at ^oC and boils at 100^oC a difference of 100^o. This means that, the Celsius degree is larger than the Fahrenheit degree. The Celsius degree is 180/100 or 1.8 times as big as the Fahrenheit degree. This 1.8 is an exact number.

To change from Celsius to Fahrenheit, one needs an equation relating the two scales. The equation relating degree Fahrenheit to degree Celsius is

$$^\circ F = 1.8^\circ C + 32$$

To convert centigrade/Celsius degree to Fahrenheit; the following expression is used.

$$^\circ C = \frac{^\circ F - 32}{1.8}$$

The conversion between Celsius and Fahrenheit scales is illustrated in the following example.

Example 4.5

- a) Normal body temperature is 37°C . What is the temperature on the Fahrenheit scale?
- b) A thermometer in a laboratory room registers 88°f . What is the temperature on the Celsius scale?

Solution

$$\begin{aligned} \text{(a)} \quad & F = 7.8^{\circ}\text{C} + 32 \\ & ^{\circ}\text{F} = (1.8 \times 37)^{\circ}\text{C} + 32 = 79.6 \Rightarrow 37^{\circ}\text{C} = 79.6^{\circ}\text{F} \\ \text{(b)} \quad & ^{\circ}\text{C} = \frac{{}^{\circ}\text{F} - 32}{1.8} = \frac{88 - 32}{1.8} = 31.11111 \quad \text{rounds to } 31^{\circ}\text{C} \end{aligned}$$

The laboratory room temperature = 31°C .

SELF ASSESSMENT EXERCISE 5

1. A certain bacteria culture was maintained at 35°C . What is the temperature in degrees Fahrenheit?
2. A boy runs a fever with a temperature of 105°F Record this temperature in degree Celsius.

4.0 CONCLUSION

In this unit it was shown that, most of the calculations or problems encountered in mathematics and science involve conversion from one unit to another. In this wise, you have been treated to a number of procedures involved in the conversion of one unit of measurement to another. Generally the use of dimensional analysis was extensively discussed as a typical example of method of dealing with problems involving conversion from one unit to another.

5.0 SUMMARY

In this unit, you have learnt that:

- Most of the problems encountered in science and mathematics involve conversion from one unit of measurement to another.
- One of the methods that can be used to achieve conversion is dimensional analysis.
- The use of dimensional analysis follows certain procedural steps.
- In the process of conversion the use of conversion factor(s) and equivalent statement(s) are of importance.
- It is possible to convert one metric unit of measurement to another e.g. from gram to kilogram
- It is also possible to convert between any two units e.g. Celsius scale to Fahrenheit.

6.0 TUTOR-MARKED ASSIGNMENT

1. Define (a) dimensional analysis
(b) Conversion factor.
2. Enumerate any 3 steps you would take in doing conversion by simple dimensional analysis.
3. (a) The temperature in one sunny day was 396k what was the temperature in degrees?
(b) A given liquid boils at 98⁰C under normal atmospheric pressure. Express this boiling point on the Kelvin scale.

7.0 REFERENCES/FURTHER READINGS

Darrell; D. E. and Wentworth R. A. D. (1995). *Introductory Chemistry*, Boston, Houghton Mifflin Company; 50.

Steve, A. and Jonathan, A. (2000). *Advanced Physics*, U. K, Oxford University Press, 28.

UNIT 5 DEFINITION OF DENSITY

CONTENTS

- 1.0 Introduction
- 2.0 Objectives
- 3.0 Main Content
 - 3.1 Definition of Density
 - 3.2 Calculation of Density
 - 3.3 Algebraic Manipulating of Equations
 - 3.4 Calculations with Density
 - 3.4.1 Calculating Mass from Volume and Density
- 4.0 Conclusion
- 5.0 Summary
- 6.0 Tutor-Marked Assignment
- 7.0 References/Further Readings

1.0 INTRODUCTION

In unit two of this course, you learnt about the measurement of certain quantities. Such quantities include mass and volume. These two quantities are much related, as some of the others discussed in unit two. One such other quantity which is related to mass and volume is density. So, in this unit you are going to learn about density and calculations involving density, as a way of measuring things.

2.0 OBJECTIVES

At the end of this unit, students should be able to:

- define density
- rearrange the equation that defines density, using algebraic manipulation to obtain equations for volume and mass
- write down an expression for determining the density of a substance
- calculate one of the quantities-density, mass or volume-given the other two.

3.0 MAIN CONTENT

3.1 Definition of Density

We often hear someone say that iron is heavier than wood. A more precise statement would be that iron has a greater density than wood/or simply, iron is more dense than wood. This indicates that a given volume of iron has greater mass than the same volume of wood. What

then is density? The density of a substance is the mass of the substance per unit volume. Mathematically expressed:

$$\text{Density} = \frac{\text{mass}}{\text{Volume}}$$

Thus, the density of a substance is its mass per volume. Unlike mass or volume, the density of a substance is a property that is independent of the quantity of substance whether you have 10g of iron or 50g iron, the destinies of both samples are the same.

3.2 Calculation of Density

The unit of density is grams divided by cubic centimeters (g/cm^3) or grams per cubic centimeter. This is the unit of density that we normally use for solids and liquids. The densities of gases are about 1000 times smaller.

Density is an important identifying characteristic of a substance. Example 5.1 illustrates the use of density understanding a substance.

Example 5.1

A sample of a metal has a volume of 4.05cm^3 and a mass of 36.2g. The metal is known to be either iron, nickel or platinum. The densities of these metals are $7.87\text{kg}/\text{cm}^3$, $8.90\text{g}/\text{cm}^3$ and $21\text{g}/\text{cm}^3$ respectively. What is the density of the metal in the sample?

Solution

Step 1 is to calculate the density of the sample

$$\begin{aligned} \text{Density} &= \frac{\text{mass}}{\text{Volume}} = \frac{36.2}{4.05} = 8.938272\text{g}/\text{cm}^3 \\ &= (\text{round up to } 8.94\text{g}/\text{cm}^3) \end{aligned}$$

The calculated density is greater than that of iron and much less than that of platinum. The value $8.94\text{g}/\text{cm}^3$ nearly equals to the density of nickel ($8.90\text{g}/\text{cm}^3$). The variation perhaps may be due to experimental error. We therefore conclude that the sample is made up of nickel.

SELF ASSESSMENT EXERCISE 1

Calculate the density of iron bar which has a volume of 7.7cm^3 and a mass of 5.5g.

3.3 Algebraic Manipulation of Equations

In unit 4.6, we used algebraic manipulation to convert the equation relating degrees Fahrenheit in terms of degrees Celsius, to give an equation relating degrees Celsius in terms of degrees Fahrenheit. To achieve this, we use a rule from algebra. Let's illustrate this by using an arithmetic set up. (If the rule is true for algebra, it is also true when numbers are substituted for algebraic symbols)

$$15 = 8 + 7$$

If you move 7 to the left hand side, you have $15 - 7 = 8$

This operation can also be performed with manipulations involving multiplication or division in an equation. For instance, $4 = 20/5$.

According to algebra. If you bring the number 5 to the left hand side (which is at the bottom), it is put at the top. This gives $4 \times 5 = 20$.

The defining equation for density can be rearranged as shown above to yield two other equations, one that gives the mass of a substance in terms of its density and volume and another equation that gives the volume in terms of density and mass.

To get the first new equation, start with the defining equation for density and move the volume to the left hand side.

$$\text{Density} = \frac{\text{mass}}{\text{Volume}}$$

Now, move volume to the left hand side (i.e. to the top) we have:

$$\begin{aligned} \text{Density} \times \text{volume} &= \text{mass} \\ \text{Mass} &= \text{Density} \times \text{volume}. \end{aligned}$$

Thus, if the density and volume of a substance are known the mass can be determined.

In order to get the volume, the density is moved to the bottom as can be shown below:

$$\text{Density} \times \text{volume} = \text{mass}$$

Thus:

$\text{Volume} = \frac{\text{mass}}{\text{Density}}$
--

This equation enables you to calculate the volume of an object if you know its mass and density.

In the next section of this unit, we shall perform some calculations involving density. You can use the equations just derived in those calculations. You don't have to memorize all of these equations. With a little practice in algebraic manipulation you can quickly go from the defining equation for density to equations for mass and volume.

3.4 Calculations with Density

One of the most important uses of density is to convert the volume of a substance to the mass of the substance and vice versa. The conversion of volume to mass is especially useful for liquids because of the relative ease of dispensing liquids by volume. Of course, you can obtain the volume of dry substance solid, liquid, or gas from its mass if you know its density. This can be achieved employing one of the following two methods.

- (i) algebraic method
- (ii) dimensional analysis (where density is used as a conversion factor)

The following examples serve to illustrate this:

Example 5.2

An experiment requires 35.5g of a liquid, what volume of the liquid would you need to equal this mass of the liquid. The density of the liquid is 1.48g/cm³.

Solution

1. Algebraic Method

State the defining equation:

$$\text{Density} = \frac{\text{mass}}{\text{Volume}}$$

Rearranging the equation we have

$$\begin{aligned} \text{Volume} &= \frac{\text{mass}}{\text{Density}} = \frac{35.5\text{g}}{1.48\text{g/cm}^3} \\ &= 23.9864 \\ &\text{Rounds up to } 24 \text{ cm}^3 \end{aligned}$$

2. Dimensional Analysis

You can use the density to write the conversion factors from cm^3 of the liquid to g of the liquid. This is:

$$\frac{1\text{cm}^3 \text{ of liquid}}{1.48\text{g of liquid}}$$

Now use this to convert 35.5g of liquid to cm^3

$$\begin{aligned} 35.5\text{g of liquid} &= \frac{1\text{cm}^3 \text{ of liquid}}{1.48\text{g of liquid}} \\ &\quad \frac{35.5 \times 1\text{cm}^3 \text{ of liquid}}{1.48\text{g of liquid}} \\ &= 23.99 \end{aligned}$$

Rounds up to 24cm^3

3.4.1 Calculating Mass from Volume and Density

You can also calculate the mass of any liquid sample from its volume if you know the density of the liquid. The calculation is very similar to that given in the previous example. Example 5.3 serves to illustrate this,

Example 5.3

Ethanol has a density of $0.789\text{g}/\text{cm}^3$, if the volume of a sample of ethanol is 39.7cm^3 . What is the mass?

Solution

1. Algebraic Method

$$\text{mass} = \text{density} \times \text{volume}$$

Now you substitute the values of density and volume noting that $\text{ml} = \text{cm}^3$)

$$\text{Mass} = 0.789\text{g}/\text{cm}^3 \times 39.7\text{cm}^3 = 31.323 \text{ (rounds up to } 31.3\text{g)}.$$

2. Dimensional Analysis

Using the density, you write the following factor to convert cm^3 to g.

$$\frac{0.789\text{g ethanol}}{1\text{cm}^3 \text{ ethanol}}$$

with this factor you can convert 39.7cm^3 ethanol to g ethanol.

$$\begin{aligned}
 39.7\text{cm}^3 \times \frac{0.78\text{hg}}{1\text{cm}^3 \text{ ethanol}} &= 39.7 \times 0.789\text{g} \\
 &= 31.3\text{g ethanol}
 \end{aligned}$$

SELF ASSESSMENT EXERCISE 2

An experiment calls for 8.4cm^3 trioxonitrate (V) and, you decide to measure out this quantity of trioxonitrate (v) by weighting the required amount using the known density of the acid (1.50g/cm^3). What mass of nitric acid do you need?

4.0 CONCLUSION

In this unit you have been exposed to the meaning of density as a quantity, which relates mass and volume. You also learnt the defining equation for density and how the equation can be used to determine the density of a substance. You equally learnt about how the equation can be manipulated to determine the mass and volume of a substance.

5.0 SUMMARY

In this unit you have learnt that:

- Density is a quantity that relates the mass of an object to its volume
- It is an important identifying characteristic of a substance.
- The defining equation for density is

$$\text{Density} = \frac{\text{mass}}{\text{Volume}}$$
- This expression can be manipulated to enable you determine either the mass or volume of an object.
- The unit for density is g/ml or g/cm^3
- Two main methods can be used to solve problems on density (i.e. algebraic and Dimensional analysis method).

6.0 TUTOR-MARKED ASSIGNMENT

1. Define Density
2. Write down an expression for determining the density of a substance, define all the Parameters in it stating the S. I. unit for measuring each of the parameters.
3. In an experiment involving the determination of the density of bromine. The following data were reported at the end of the experiment.

Mass of cylinder and bromine 38.53g

Mass of cylinder 24.5g

Volume of Bromine 4.50cm³

What is the density of bromine?

7.0 REFERENCES/FURTHER READINGS

Adeboye J. O. (1987). *Application of Mathematics to Chemistry*. Unpublished Memeograph, Oyo, Oyo State College of Education. 5

Darrell, D. E. and Wentworth, R. A. D. (2000). *Introductory Chemistry Boston*. Houghton Mifflin Company 56.

MODULE 2

Unit 1	Basic and Derived Units
Unit 2	Uncertainties in Measurement
Unit 3	Lines, Angles and Triangles
Unit 4	Solids and 3-Dimensional Shapes
Unit 5	Plane Shapes and Their Properties

UNIT 1 BASIC AND DERIVED UNITS

CONTENTS

1.0	Introduction
2.0	Objectives
3.0	Main Content
3.1	Basic Units
3.2	Derived Units
3.3	Standard Prefixes for S.I. Units
4.0	Conclusion
5.0	Summary
6.0	Tutor-Marked Assignment
7.0	References/Further Readings

1.0 INTRODUCTION

Unit two of this course dealt extensively with standard units of measuring certain physical quantities such as length, mass, volume, time and temperature.

This unit will be devoted to classifying these and other units of measurement into basic and derived units. We will also look at customized units. By convention scientists and engineers use the international system of units. This set rule defines seven basic units and various derived units obtained from them.

2.0 OBJECTIVES

At the end of this unit, students should be able to:

- define basic units and derived units
- distinguish between basic units and derived units
- list examples of basic units and derived units
- mention the various prefixes used in classifying S.I units
- classify prefixes into multiples and submultiples
- identify some common SI numbers and units.

3.0 MAIN CONTENT

3.1 Basic Units

Scientists have discovered that they can measure any quantity in nature in terms of small number of basic units. There are basically seven units. They are as presented in table 6.1. The essence of using these units by scientists, engineers and mathematicians was to have a suitable way of measuring anything that crops up. The advantage of using this set of agreed units is that scientists from all over the world can exchange ideas and design for experiments without having to translate specifications into different units. It is like having a common language. The S.I units present a set of agreed standards against which people can check their measuring devices. The system of units relies on simple physical effects.

Table 6.1: Basic Units and Their Measurements

Quantity	Units	Definition
Time	Second(s)	the time taken for 919263A770 periods of the radiation emitted when an electron makes a transition between two specified energy level of the ground state of a ^{133}Ca atom
Mass	Kilogram (kg)	The mass of a platinum- indium cylinder held at the international bureau of weights and measure in severses frame.
Length	Meter (M)	The distance traveled by light in a vacuum during a time interval of $1/29979245855$.
Current	Ampere (A)	The instant current which if maintained in two straight parallel inductors of infinite length negligible cross section placed in apart in a vacuum, would produce a magnet force between the conductors of 2×10^{-7} N for every meter length
Temperature	Kelvin (K)	The thermodynamic temperature of the triple point of the water (the condition in which water, ice, and steam are in equilibrium) is defined as 273K above absolute zero
Amount of substance	Mole (MOL)	The number of atoms in 0.012kg of ^{12}C
Intensity	Candela (CD) the candela is a fairly specialist units used in the study of luminous objects.	The luminous intensity in a given direction of a source that a unit monochromatic radiation (i.e. radiation of one colour or wavelength of frequency 5.40×10^{13} Hz having a radiant intensity in that direction of $1/683$ W per steradian (an S. I. units for solid angles)

3.3 Derived Units

The derived units enable us to measure more than basic quantities of length, time, mass etc. For instance, there is no unit for speed among the basic units. However, a suitable unit can be derived from the equation for speed.

$$\text{Average speed} = \frac{\text{distance (m)}}{\text{Time taken (s)}}$$

This suggests that the unit of speed is metres divided by second, however, such a division is impossible. Division can only happen when the quantities are of the same type. Instead, we say that the unit of speed is metres per second and write it as ms^{-1} . So, when a lorry is moving at a constant speed of 200m in 10s, it means that it must cover a distance of 20m in 1s, or 20ms^{-1} .

Acceleration is another important quantity in science it refers to the rate of at which speed is changing.

$$\text{Average acceleration} = \frac{\text{final speed (ms}^{-1}\text{)} - \text{initial speed (ms}^{-1}\text{)}}{\text{Time taken(s)}}$$

This is a little bit trickier to handle. The top line is the difference between two quantities measured in ms^{-1} . The bottom line is in seconds. So the units of acceleration are metres per second per second or ms^{-2} . What an acceleration of 20ms^{-2} means is that in every second the speed increases by 20 metres per second.

The following table 6.2 shows some of the derived units that are commonly encountered in scientific enterprise.

Table 6.2: Derived Units

Quantity	Derived unit	Name
Speed	ms^{-1}	-
Acceleration	ms^{-2}	-
Force	kg ms^{-2}	Newton (N)
Pressure	$\text{Kgm}^{-1} \text{s}^{-2}$	Pascal (Pa)
Energy	$\text{Kgm}^2 \text{m}^{-2}$	Joule J
Charge	As	Conlumb (C)
Potential difference	$\text{Kgm}^2 \text{A}^{-1} \text{s}^{-3}$	Volt (V)
Resistance	$\text{Kgm}^2 \text{A}^{-2} \text{s}^{-3}$	Chm (Ω)

SELF ASSESSMENT EXERCISE 1

1. What do you mean by (i) Basic unit (ii) Derived unit?
2. State one advantage of the units of measurement in (i) and (ii) above.

3.4 Standard Prefixes for S. I. Units

Physical quantities cover an incredibly wide range of values, so prefixes are used to give multiples and submultiples of basic units. For example it is not reasonable to measure the height of a man in kilometers or his mass in tones. It is much more convenient to choose a unit comparable in size to the quantity that is being measured. In the same vein the thickness of a hair could be measured in micrometres (millionths of a metre) while the voltage on a generator is measured in kilovolts (i.e. thousands of volts).

The standard multiples and submultiples are in steps of 10^3 . For example a millimeter is one thousandth of a metre and a kilometer is one

thousand metres. However, there are prefixes that are sometimes used but that do not fit this pattern. The centimeter is the most common of these (i.e. one hundredth of a metre). Table 6.3 gives examples of prefixes, multiples and submultiples.

Table 6.3: Standard Prefixes

Prefix	Symbol	Multiplies unit by Multiples	Example
Kilo -	K	10^3	1kv = 1000v
Mega-	M	10^6	1MW = 10^6 w
Giga	G	10^9	1GW= 10^9 w
Tera	T	10^{12}	1TW= 10^{12}
Peta	P	10^{15}	1PM= 10^{15}
Exa	E	10^{18}	1EM= 10^{18}
Sub Multiples			
Milli	m	10^{-3}	1mA= 10^{-3} A
Micro	μ	10^{-6}	1 μ V= 10^{-6} v
Nano	n	10^{-9}	1nm= 10^{-9} m
Pico	p	10^{-12}	1pj= 10^{12} J
Femto	f	10^{-15}	1fm= 10^{-15} m
Atto	a	10^{-18}	1am= 10^{-18} m
Deci	D	10^{-1}	1DM = 0.1M
Centi	C	10^{-2}	1cm = 0.01m

Example 6.1

How many cubicmillimetres are there in a cubic metre?

Solution

$$1\text{m} = 10^3\text{mm}$$

$$\text{So, } (1\text{m})^3 = (10^3\text{mm})^3 = 10^9\text{mm}^3$$

3.4.1 Scale Model

A calculation very similar to that in example 6.1 is involved whenever we scale up a model. If a model tree has height 12cm and is to a scale of 1:50, then the real tree has a height of $12 \times 50\text{cm} = 6\text{m}$. However its volume depended on the cube of its linear dimensions and so is $50^3 = 125000$ times greater than the volume of the model. Its mass will also increase by a similar factor, assuming that the density of the modeling

material is close to the real tree. However, great care must be taken when results achieved using a model are to be applied to the real thing.

4.0 CONCLUSION

In this unit, you have learnt about the seven basic units and derived units (which are derived from the basic units). You also learnt that measuring in basic units enable scientists, mathematician and engineers to exchange ideas and design experiments in the same units. Some standard prefixes for S. I. units were also discussed.

5.0 SUMMARY

In this unit you have been treated to the following:

- That by convention scientists and engineers use the international system of units.
- The S. I. units define seven basic units and a number of derived units.
- The basic units enable scientists, engineers and mathematicians to measure using the same specifications.
- Derived units are obtained from the basic units by comparing two or more basic units.
- Because physical quantities cut across wide range of values a set of standard prefixes are used to give multiples and submultiples of basic units.

6.0 TUTOR-MARKED ASSIGNMENT

1. Mention the seven basic quantities stating their symbols and units.
2. State one advantage of measuring in the basic unit.
3. State any six examples of physical quantities that use derived units of measurement.

7.0 REFERENCES/FURTHER READINGS

Adeboye J. O. (1987). *Mathematics for Chemistry*. Unpublished Mimeograph, Oyo, Oyo State College of Education.

Steve A, Jonathan A. (2000). *Advanced Physics*. U. K. Oxford University Press. 28-30.

UNIT 2 UNCERTAINTIES IN MEASUREMENT

CONTENTS

- 1.0 Introduction
- 2.0 Objectives
- 3.0 Main Content
 - 3.1 Meaning of Uncertainties in Measurement
 - 3.2 Quoting Uncertainties
 - 3.3 Estimating Uncertainties
 - 3.3.1 Precision Instruments
 - 3.4 Types of Uncertainties
 - 3.5 Percentage Uncertainties
 - 3.5.1 Combining Uncertainty
- 4.0 Conclusion
- 5.0 Summary
- 6.0 Tutor-Marked Assignment
- 7.0 References/Further Readings

1.0 INTRODUCTION

In unit three a brief mention was made of uncertainty in measurement. This was united to significant figures. In this unit, you will learn more about uncertainty and how it could be obtained. You will also learn about the cause and different kinds of uncertainties that you may come across in scientific measurement as well as how you can determine the percentage uncertainty in a given set of measurement.

2.0 OBJECTIVES

At the end of this unit you should be able to:

- explain the concept of uncertainty in measurement
- list some causes of uncertainty
- mention various types of uncertainties in measurement
- calculate the percentage uncertainty in a given set of measurement.

3.0 MAIN CONTENT

3.1 Meaning of Uncertainty in Measurements

Generally, uncertainties are natural variations in measurements that come about for a variety of reasons ranging from human to instrumental. Naturally, when scientists observe an uncertainty in a measurement, they do not mean that they are not sure of its value. Uncertainties, which

are sometimes called errors, are not mistakes. The following are the causes of uncertainties in measurements:

- (i) No instrument is exactly precise
- (ii) Different people may use different types of instrument.
- (iii) No two people can read an instrument in exactly the same way
- (iv) Sometimes instruments are read wrongly.
- (v) The instrument adjustment may have changed.

No matter how carefully we set up experiments, problems like these always arise. Scientists always try to estimate the extent of to which the result of the experiment have been influenced by these variations.

3.2 Quoting Uncertainties

If you read a scientific paper, you will find that the numerical results include a second number and a (\pm) symbol e.g.

$3.5 \pm 0.2 \times 10^{-10}$ seconds

Example 7.1

A class of pupils measures the length of a door bench using a 30cm ruler calibrated in millimetres. The following results were obtained.

4.90cm, 4.95cm, 4.92cm, 4.96cm 4.93cm, 4.91cm what is the length of the bench?

Solution

The average of value of these results is 4.93 (3 sig. fig) and this is the result to be quoted as the length of the bench. However, only one result agrees with this average, so all others are wrong.

All of the results lie within 0.03cm of the average result and we say, the length of the block is 4.93 ± 0.03 cm

SELF ASSESSMENT EXERCISE 1

How would you quote the following results from a repeated experiment?

2.00cm, 1.98cm, 1.99cm, 2.02cm, 1.97cm, 2.01cm.

3.3 Estimating Uncertainties

Repeating a measurement several times and charting the results produces a distribution from which the uncertainty can be obtained. This is the method used by professional scientists. In practice, measurements are not often repeated. Instead some rules of thumb help to estimate the uncertainty. This is as shown in the following table 7.3.1

Table 7.3.1 Estimating Uncertainties

Measurement	Typical equipment	Rule of thumb
Rending scales	Rulers, verniers, dials	Halve the smallest division
Timing	Clocks, stopclocks etc	Halve the smallest scale division or reaction time typically $\sim 0.55t$ whichever is the larger
Counting	Geiger counter	If the number counts is N , then the uncertainty is always \sqrt{N}

3.3.1 Precision Instruments

Several instruments have features that enable them to make measurements to a high degree of precision. Some of the instruments that provide precise measurements in different circumstances are given table in 7.3.2

Table 7.3.2 Instruments for Precise Measurements

Measurement	Typical use
Venier calipers	Length and diameters
Micrometer	Small diameters and thickness
Traveling microscope	Distances, depth, e.t.c
Spectrometer	Wavelengths of light.

3.4 Types of Uncertainties

In scientific terms, there are two main types of uncertainties, which bother on accuracy and precision. These uncertainties can either be systematic or random.

(i) Random Uncertainties

Random uncertainties show no pattern from one measurement to another. Charting a set of results produces a cluster round an average value and in most cases the chart will be a normal distribution. The

width of the distribution is a measure of the random uncertainty in the data.

For a normal distribution, the width is one standard deviation and covers about two-thirds of the data.

Random uncertainties arise due to some reasons. These include:

- (a) Change due to reading taken by different people.
- (b) Reading instrument may change from one measurement to another.
- (c) Different experimental situation may use slightly different equipment.

A precise measurement has a small random uncertainty e.g. 5.3 ± 0.01 is very precise.

In the first result, there is no point in quoting more than two significant figure; because the uncertainty is smaller. Random uncertainties hint the precision of a measurement. One or two readings a long way from the average can have a big influence on the measurement if only a few that are taken. When many readings are taken, the few that are a long way from the average have little effect. Thus, by taking more readings it is always possible to reduce the size of a random uncertainty.

(ii) Systematic Uncertainties

A systematic uncertainty shifts all the measurements away from the true value by the same amount and it can significantly affect the accuracy of a measurement. This usually happens whenever, a measuring instrument goes out of alignment or if it is not calibrated properly. For instance, if a metre ruler was actually 99.8cm long, it would introduce a systematic uncertainty.

Systematic uncertainties are difficult to avoid. Taking more readings will not affect the systematic uncertainty because it is present in all of the readings. The best method of determining if this kind of uncertainties exists in an experiment is to use the equipment to measure a known quantity first. This is known as Calibrating the equipment; and it's a very important step.

3.5 Percentage Uncertainty

Sometimes it is useful to determine how large an uncertainty is as a percentage of the measurement's value.

This is determined using the following expression:

$$\% \text{ Uncertainty} = \frac{\text{Size of uncertainty}}{\text{Size of measurement}} \times 100\%$$

The example 7.5.1 illustrates this.

Example 7.5.1

A particular instrument was used to measure the rate at which the universe is expanding. The result gave $23 \pm 7 \text{ km s}^{-1}$ million light years. What is the percentage uncertainty in the measurement?

$$\% \text{ uncertainty} = \frac{7}{23} \times 100\% = 30\%$$

SELF ASSESSMENT EXERCISE 2

An angle is measured as $30.0 \pm 0.1^\circ$. What is the size of the angle and uncertainty in the size?

3.5.1 Combining Uncertainty

Scientists most often than not combine measurements to obtain a final result. The uncertainty of this result will depend on the uncertainties of the individual measurements. In simplest case, the uncertainties must be added together. The example 7.5.2 illustrates what we are trying to explain here.

Example 7.5.2

The inner radius of a spin dryer is $5.0 \pm 0.2 \text{ mm}$ and the outer radius is $8.0 \pm 0.2 \text{ cm}$. What is the width of the dryer?

$$\text{Width} = 8.0 - 5.0 \text{ mm} = 3.0 \text{ mm}$$

However, it could be as big as $(8 + 0.2) - (5 - 0.2) \text{ mm} = 3.4 \text{ mm}$ or as small as $(8 - 0.2) - (5 + 0.2) \text{ mm} = 2.6 \text{ mm}$.

The range of possible value is $2.6 \text{ mm} - 3.4 \text{ mm}$, that, $3.0 \pm 0.4 \text{ mm}$.

In more complicated situations, measurements may have to be multiplied, divided, or operated on by some function, for example, sin or log. It is possible to derive these rules for calculating uncertainties using calculus; but in most cases, simple rules of thumb provide answers that are good enough.

Table 7.5.1 Combining Uncertainties

Situation	Uncertainty
Adding/ subtracting measurements	Add uncertainties
Multiplying/ dividing measurements	Add % uncertainty
Functions of measurements (log, sin, etc)	

4.0 CONCLUSION

In this unit, you have so far been exposed to knowledge about uncertainties that do occur in measurement due to reasons that could be human or instrumental. Some of these uncertainties could only be reduced but not completely eradicated. It could be minimized by taking several measurements and the use of rule of thumbs.

5.0 SUMMARY

In this unit, you have learnt that:

- Uncertainties in measurements is a common phenomena in science or mathematics.
- Uncertainties has to do with variations in measurements that arise as a result of a number of reasons.
- There are two main types of uncertainties, these are, random and systematic uncertainties.
- It is often useful to determine to the percentage uncertainty in a given set of measurements.
- In order to obtain final results, scientist often find it worthwhile to combine measurements.

6.0 TUTOR-MARKED ASSIGNMENT

1. What do you mean by uncertainties in measurements?
2. (a) List any 5 reasons that lead to uncertainties in measurements?
(b) Mention two types of uncertainties in measurements?
3. Given the equation for the period of a pendulum as $T=2\pi\sqrt{\frac{l}{g}}$

Where l is the length of the string and g is the acceleration due to gravity.

If $L=54\pm 0.15$ and $g = 9.8\pm 0.1\text{ms}^{-2}$ what is the period and the uncertainty in the period? ($\pi = 3.14$).

7.0 REFERENCES/FURTHER READINGS

Adeboye, J. O. (1987). *Application of Mathematics to Chemistry*. Unpublished mimeograph Oyo, Oyo State College of Education, 30.

Steve, A. and Jimathan, A. (2000). *Advanced Physics*. U. K. Oxford University Press; 30-36.

UNIT 3 LINES, ANGLES AND TRIANGLES

CONTENTS

10	Introduction
2.0	Objectives
3.0	Main Content
3.1	Kinds and Basic Properties of Lines and Angles
3.2	Properties of Parallel Lines
3.3	Intersecting Lines
3.4	Angles
3.4.1	Kinds of Angles
3.4.2	Other Forms of Angles
3.5	Kinds and Properties of Triangles
3.5.1	Kinds of Triangles
3.5.2	General Properties of Triangles
3.5.3	Area of a Triangle
3.6	Congruent Triangles
3.6.1	Conditions for Congruency
3.7	Similar Triangles
3.8	Pythagoras Theorem
4.0	Conclusion
5.0	Summary
6.0	Tutor-Marked Assignment
7.0	References/Further Readings

1.0 INTRODUCTION

In your ordinary level mathematics you have been introduced to some elements of geometry. Geometry, you know, is a branch of mathematics that deals with the study of linear measurements and angular or rotational measurements. It is also the study of shapes and figures bounded by lines and curves. Geometry has a wide range of application in the physical world especially in such fields as architecture, engineering, survey, environmental sciences, in industries, in aromatics, in navigation, in space travel e.t.c. In our treatment of geometry in this course we shall look at shapes of figures their properties and problems relating to these shapes. Specifically this unit is aimed at discussing kinds and basic properties of lines angles and triangles.

2.0 OBJECTIVES

At the end of this unit students should be able to:

- explain the meaning and kinds of straight lines
- recognize parallel lines and their properties
- distinguish between different kinds of angles and triangles
- identify the properties of different angles and triangles
- draw different kinds of lines.

3.0 MAIN CONTENT

3.1 Kinds and Basic Properties of Lines and Angles

A straight line is the shortest distance or the shortest line between any 2 points x and y (see fig 8.1).



Fig. 1.1

Different kinds of straight lines exist. These are:

- Vertical
- Horizontal
- Oblique
- Parallel and perpendicular lines
- Transversal
- Intersecting lines.



- A vertical line runs straight from top to bottom of paper or the planar or facing the north it runs north to south (see 1.2(ii)).
- A horizontal line runs across the paper the paper or straight from west to east {see 1.2(ii)}.
- An oblique line is neither vertical nor horizontal (i.e neither straight, upright, not straight across the paper or place {see 1.2 (iii)}).
- Parallel lines are lines that are drawn such that they can never meet no matter how they are produced in either direction, they are usually denoted by small arrows in them {see fig 1.2(iv)}

Some authors however would define. Parallel lines as lines that are always same distance apart, the symbol for a parallel line is // or //

- A transversal line is a line which cuts two or more parallel line. It can also be called a cutting line XY is the transversal line in fig 1.2(v).
- Two lines AB and CD are perpendicular to each other when they make an angle of 90° where they meet (see fig 1.2(vi). Symbol for perpendicular line is \perp or \perp ar.

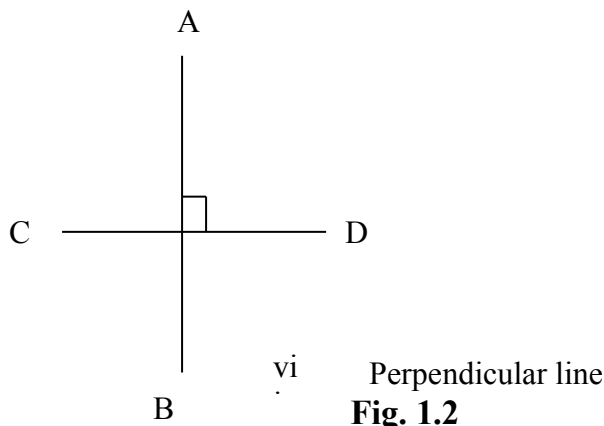
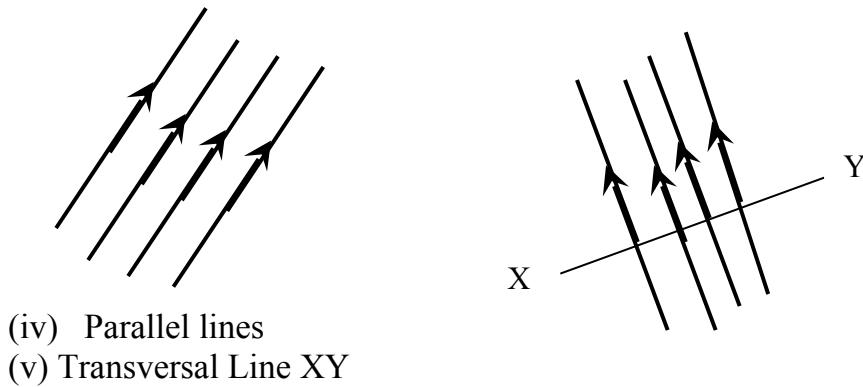
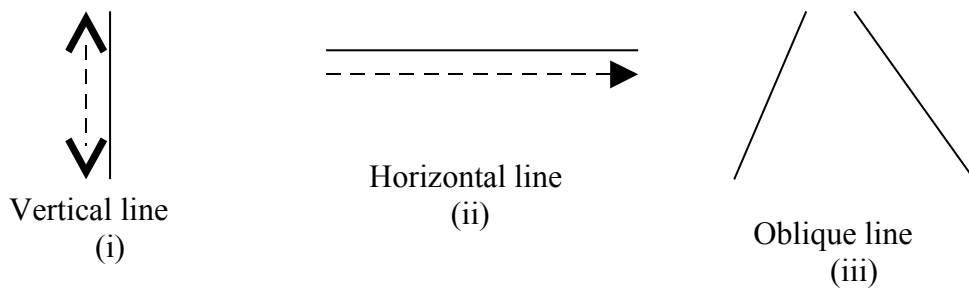

Fig. 1.2

3.2 Properties of Parallel Lines

If AB, CD and EF are parallel lines and YZ is a transversal line then a number of angles are created (see fig 1.3)

These angles a,b,c,d,e,f,g,h,i,j,k and l have some properties these are as shown below.

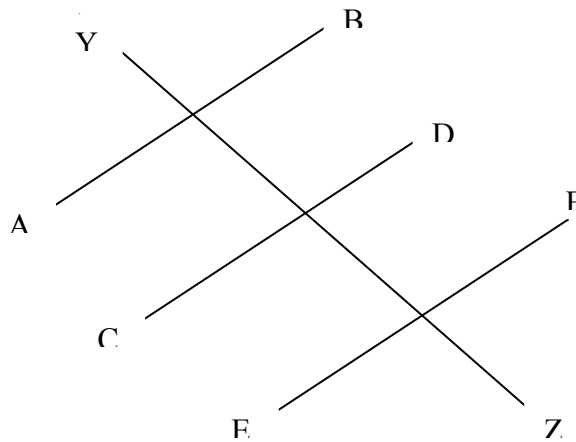

Fig. 1.3

a) Alternate angles are equal

These are $\angle d = \angle f$
 $\angle c = \angle e$
 $\angle h = \angle j$
 $\angle g = \angle i$

b) Corresponding angles are equal

These are $\angle b = \angle f = \angle j$
 $\angle a = \angle e = \angle i$
 $\angle d = \angle h = \angle l$ and
 $\angle c = \angle g = \angle k$

Students should note that these corresponding angles occupy corresponding or similar positions in the diagram or fig 1.3.

c) The parallel angles are supplementary i.e add up to 180. This property of parallel lines can be expressed in other ways (;) interior angles on the same side of the transversal add up to 180 these are

$$\begin{aligned} \angle d + \angle e &= 180^\circ \\ \angle c + \angle f &= 180^\circ \\ \angle h + \angle i &= 180^\circ \\ \text{and } \angle g + \angle j &= 180^\circ \end{aligned}$$

These properties of parallel lines are important and useful in solving problems.

3.3 Intersecting Lines

When two lines AB and CD cut across each other as in fig 1.4 they form angles a,b,c,d, with the properties stated below:

- i) Vertically opposite angles are equal
 i.e $\angle a = \angle b$
 $\angle b = \angle d$

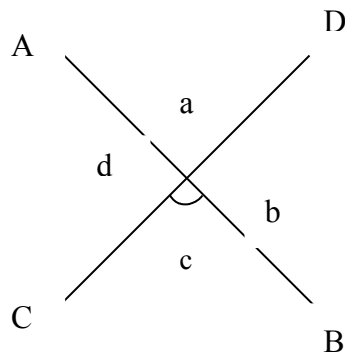

Fig. 1.4

- ii) Adjacent angles on a straight line are supplementary
 i.e $\angle a + \angle b = 180^\circ$
 $\angle b + \angle c = 180^\circ$
 $\angle c + \angle d = 180^\circ$
 $\angle d + \angle a = 180^\circ$

Example 1.4.1

Find angles a and c in the fig 8.5 show if given that AB is parallel to CD

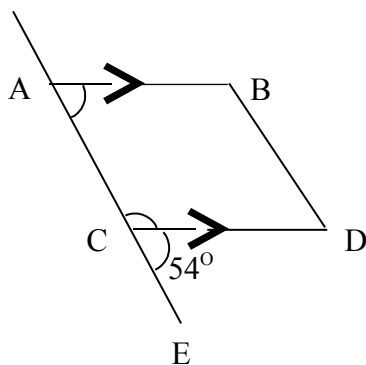

Fig. 1.5

Solution

Since adjacent \angle s on a straight line add up to 180° then

$$\begin{aligned} &< c + 54^\circ = 180^\circ \\ &< c = 180^\circ - 54^\circ = 126^\circ \\ \text{but } &< a = < c \text{ (corresponding } \angle \text{ s)} \\ &< a = 126^\circ \end{aligned}$$

SELF ASSESSMENT EXERCISE 1

Find angles a and b in the fig 1.6 shown below if PQ and XY are parallel lines.

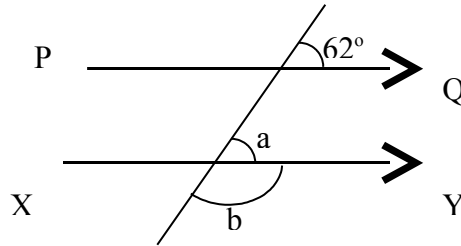

Fig 1.6

3.4 Angles

An angle can be defined as a measure of rotation or turning .It is measured in degrees. When two lines meet or cut each other, they form angles. Also when a person facing a particular direction turns or rotation to face another direction, he has turned through an angle, these examples are illustrated in figure 1.7.

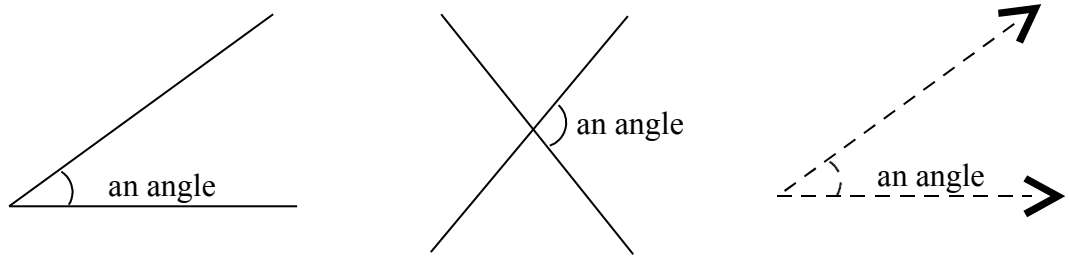

Fig. 1.7

3.4.1 Kinds of Angles

There exist different kinds of angles each of which is illustrated in fig 1.8(I)-(viii). These angles are:

- i) A right angle: - this is the angle 90° which is denoted by $rt \angle$.
- ii) An acute angle: - this is an angle that is less than 90°
- iii) An obtuse angle: - this is an angle that is less than 180° , but greater than 90° .
- iv) Angle on a straight line: - this is an angle that is equal to 180°

- v) Reflex angle: this is an angle that is greater than 180° but less than 360°
- vi) Adjacent angles: - These are angles that are adjacent or next to one another. Adjacent angles on a straight line add up to 180° . (see fig 1.8 where $a + b + c = 180^\circ$).

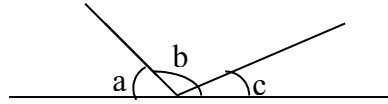
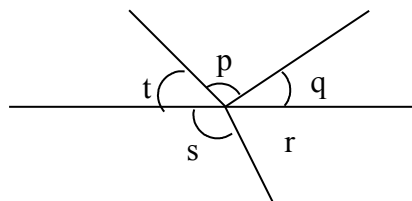

Fig. 1.8: Adjacent Angles

- vii) Angles at a point or sometimes regarded as a complete angle, or a revolution: - these are angles that add up to 360° . (see figure 8.9 – where all the angles p, q, r, s, t, all add up to 360°)



$$(p + q + r + s + t = 360^\circ)$$

Fig 1.9: Angles at a Point

Having identified the different kinds of angles, we can now draw diagrams to illustrate each kind as enumerated in 1.6.1 (i) – (vii) above.

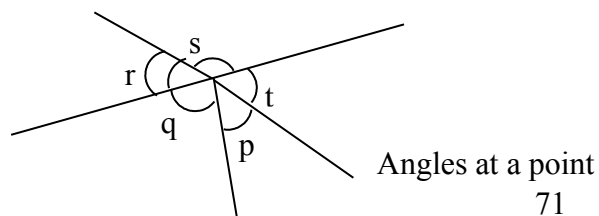
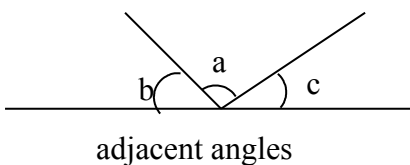
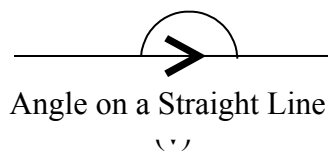
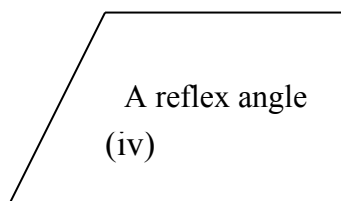
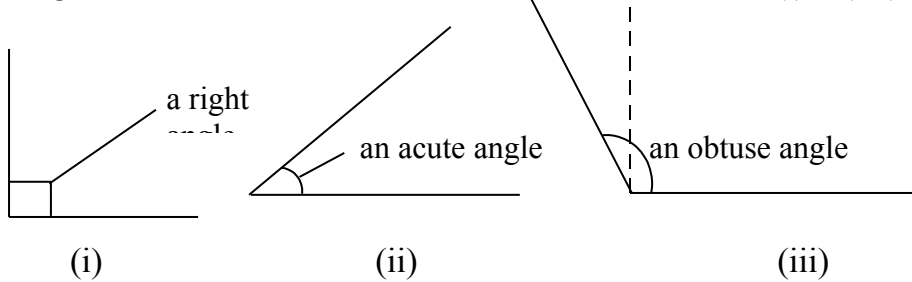

(vi)

(vii)

Fig. 1.10

3.4.2 Other Forms of Angles

Other forms of angles also exist, in addition to those identified in the preceding section. These are:

- (i) Elementary angles: - These are formed when two or more angles add up to 90°
- (ii) Supplementary angle: - this is formed when two or more angles add up to 180° . It should be noted that, parallel angles and adjacent angles on a straight line are supplementary angles.
- (iii) A right angle is formed when a vertical line meets or cuts a horizontal line (see figure 1.11 (i) and (ii))

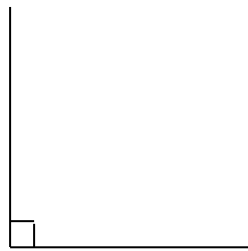

(i) right angle

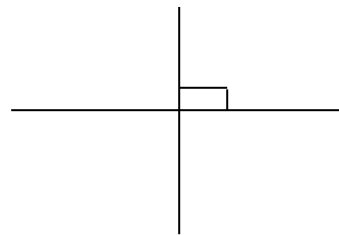

(ii) right angle

Fig. 1.11

- (iv) When two lines make right angle where they meet each other, the lines are said to be perpendicular. Therefore, every vertical line is perpendicular to every horizontal line.

Finally, it is usually helpful to mark equal angles alike and mark unequal angles differently for the purpose of clarity. Figure 1.12 (i) and (ii) attest to this

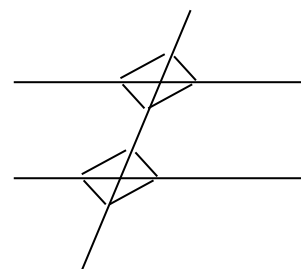
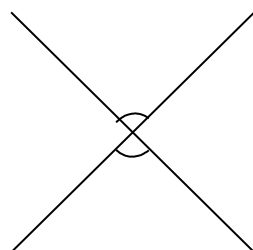

(i)

(ii)

Fig. 1.12

3.5 Kinds and Properties of Triangles

A triangle is a closed three-sided figure with three angles. In dealing with issues that have to do with triangles, we are usually concerned with, these kinds of triangles, congruent triangles and similar triangles. Ordinarily a triangle is usually represented with the symbol Δ .

3.5.1 Kinds of Triangles

- Considering the sides, the three kinds are - equilateral Δ , an isosceles Δ and a scalene Δ .
- If angles are considered, a triangle has three kinds, acute angled Δ , an obtuse angle Δ , and a right angle Δ .

In an equilateral triangle, all the sides are equal that is they are of equal length. An Isosceles triangle has two of its sides equal; while a scalene triangle possesses three unequal sides.

3.5.2 General Properties of Triangles

Generally, triangles have the following properties

- An equilateral Δ has all the angles equal as well as the sides. Each angle is equal to 60° . (see figure 1.13).

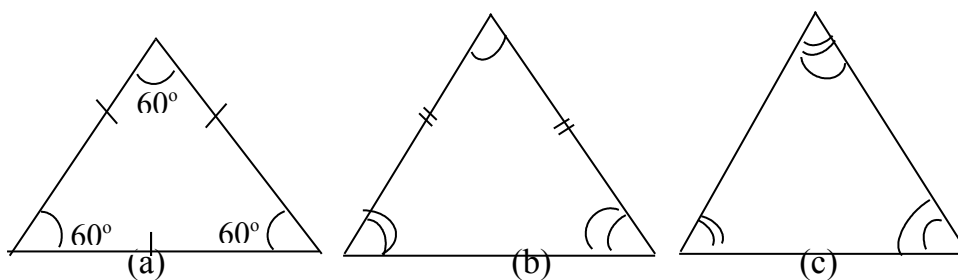
**Fig. 1.13**

- An isosceles triangle has two equal sides and two base angles equal (see fig 1.13 (b))
- A scalene has no equal side and no equal angle. (see fig 1.13c).

When triangles are drawn, all the information about the triangle is usually incorporated into the diagram, equal sides and equal angles are marked in the same way.

- iv) The sum of the three angles of any triangle add up 180° (see fig 1.14 (a)) i.e. $\angle X + \angle Y + \angle Z = 180^\circ$

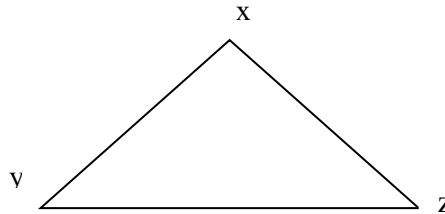

Fig. 1.14(a)

- v) If one side of any triangle is produced, the exterior angle formed equals the sum of the two opposite angles.

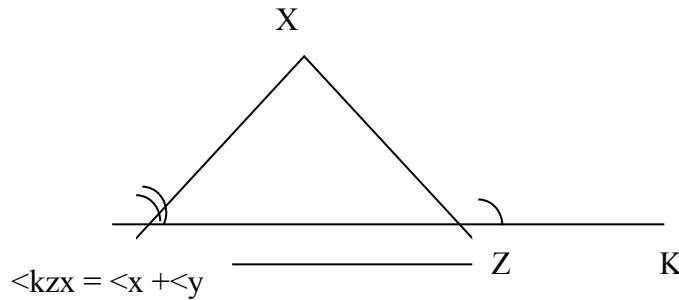
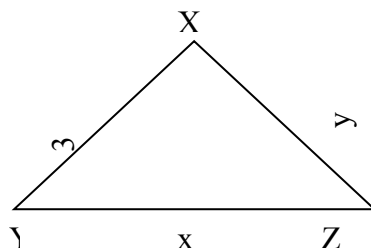
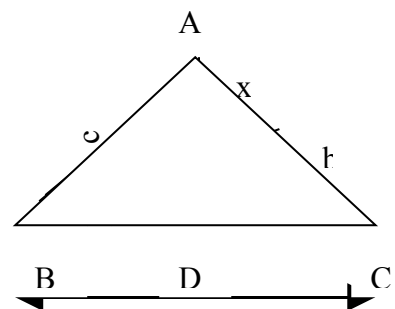

Fig. 1.14 (b)

Students should note that in geometry, capital letters are often used for angles, while the sides opposite are denoted with their small letters, unless otherwise stated. (see fig 1.15(ii)).



(i)



(ii)

Fig 1.15

3.5.3 Area of a Triangle

Let us consider any triangle ABC with the usual notation, BC = a, AB = c and AC = b, the angles are $\angle A$, $\angle B$ and $\angle C$

From fig 1.15 (ii) we can define area of ΔABC
 $= \frac{1}{2}$ base x perpendicular height
 $= \frac{1}{2} \times BC \times AD$

Where AD is the perpendicular height (or the altitude) of the Δ from the base, BC

Thus, Area of $\Delta ABC = \frac{1}{2} BC \times AD$ (i)

If we consider ΔABD , we have that $\sin \angle B = \frac{\text{opposite}}{\text{hypotenuse}}$
 i.e. $\sin B = \frac{AD}{AB}$

Therefore, the altitude; $AD = AB \sin B$

If we substitute this in the above expression (i), we have that the
 Area of $\Delta ABC = \frac{1}{2} BC \times AB \sin B$
 $= \frac{1}{2} a \times c \sin B = \frac{1}{2} ac \sin B$(ii)

If we consider ΔADC , we obtain that

$$\frac{AD}{AC} = \sin C \text{ and}$$

Therefore, $AD = AC \sin C = b \sin C$

Substituting in (i) above, we have

$$\text{Area of } \Delta ABC = \frac{1}{2} (BC \times b \sin C) = \frac{1}{2} a \times b \sin C = \frac{1}{2} ab \sin C$$
..... (iii)

If we consider ΔADC , we obtain that $\frac{AD}{AC} = \sin C$ and

Therefore $AD = AC \sin C = b \sin C$

Substituting in (i) above, we have

$$\text{Area of } \Delta ABC = \frac{1}{2} (BC \times b \sin C) = \frac{1}{2} ab \sin C$$
..... (iii)

If instead of drawing the perpendicular AD, we had drawn the perpendicular BX to AC, we could prove in similar manner that the

$$\text{Area of } \Delta ABC = \frac{1}{2} bc \sin A$$
..... (iv)

Combining equations (ii) (iii) and (iv) we have that the area of $\Delta ABC = \frac{1}{2} ab \sin C = \frac{1}{2} ac \sin B = \frac{1}{2} bc \sin A$.

This formula for the area of a triangle is useful in solving problems in geometry and holds for any kind of triangle be it acute-angled, obtuse-angled or right angled triangle.

Example 1.7.1

In a triangle ABC, AD the altitude of the triangle is 9cm, if BC = 12cm. Find the area of the ΔABC .

Solution

Given AD = 9cm
 BC = 12cm

Required: To find the area of ΔABC
 Area of ABC = $\frac{1}{2}$ base x height
 = $\frac{1}{2} \times 12 \times 9 = 54\text{cm}^2$

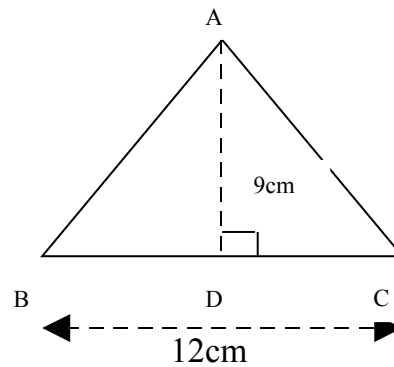

Fig. 1.6

Example 1.7.2

Find the area of XYZ using the formular $\frac{1}{2} ab \sin c$, given that YZ= 10cm and $\angle y = 90^\circ$

Solution

Using the usual notation, here XY=z,
 YZ=x and XZ = y

Therefore,
 Area of $\Delta XYZ = \frac{1}{2} x z \sin Y$
 = $\frac{1}{2} \times 10 \times 8 \times \sin 90^\circ$

But $\sin 90^\circ = 1$
 Therefore, angle xyz = $\frac{1}{2} \times 10 \times 8 \times 1$
 = 40 sq cm^2

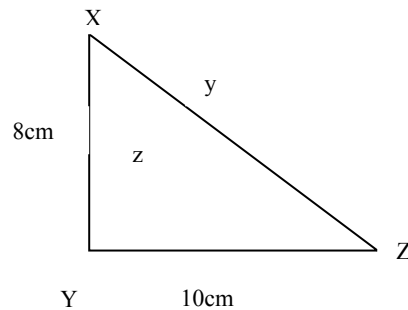

Fig 1.17

SELF ASSESSMENT EXERCISE 2

Find the area of triangle ABC in which a = 5.25cm, b = 7.36cm and c = 3.49 cm.

Consider the triangle ABC, with the usual notation, we define the perimeter of the triangle as 2s

i.e. $2s = a + b + c$
 $s = \frac{1}{2} a + b + c$

It can be shown that the area of triangle $ABC = \sqrt{s(s-a)(s-b)(s-c)}$

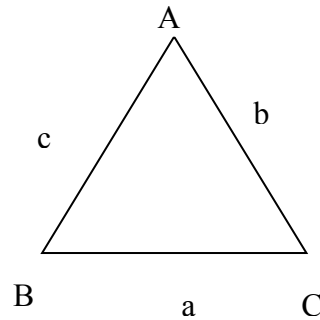

Fig. 1.18

This formula for the area of the Δ is useful especially when no angle size is given, but only the sides of the triangle.

Example 1.7.3 serves to illustrate this:

Example 1.7.3

Find the area of triangle ABC in which $a = 6.55$ cm $b = 9.36$ cm and $c = 5.49$ cm. (see fig 8.19)

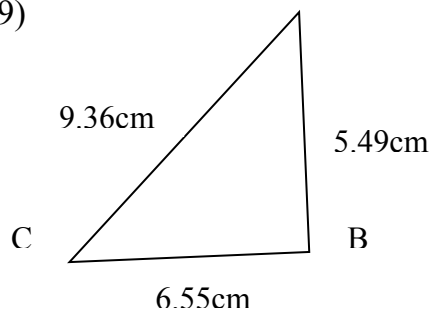

Fig. 1.19

Solution

The perimeter of $\Delta ABC = 2s$

This, $2s = 9.36 + 6.55 + 5.49$ cm

$$= 21.4$$

$$s = \frac{1}{2} \times 21.4 = 10.7$$

$$s - a = 10.7 - 6.55 = 4.15$$

$$s - b = 10.7 - 9.36 = 1.34$$

$$s - c = 10.7 - 5.49 = 5.21$$

$$\text{Therefore, area of } \Delta = \sqrt{s(s-a)(s-b)(s-c)}$$

$$= \sqrt{10.7 \times 4.15 \times 1.34 \times 5.21}$$

$$= 310.01$$

3.6 Congruent Triangles

Definition

When two or more triangles are congruent. Their angles are equal. If one is lifted up, it can be placed exactly over the other. They are also equal.

are said to be congruent if one is lifted up, it can be placed exactly over the other. They are also equal.

3.6.1 Conditions for Congruence

Below are the conditions for the congruence of two triangles.

- i.) If the three sides of one triangle are equal to the three sides of another triangle XYZ, then the triangles are congruent.

This condition is usually represented as Side-Side-Side (SSS) or angle-angle-side (AAS). In the second notation, great care must be taken to ensure that the order of naming the triangles makes corresponding vertices of the two triangles correctly indicated. i.e. vertices A, B, C correspond to vertices X, Y, and Z respectively. Such that $\angle A = \angle X$, $\angle B = \angle Y$ and $\angle C = \angle Z$ while the sides $AB = XY$, $BC = YZ$ and $AC = XZ$. e.t.c fig. 1.20 (i) and (ii) illustrate these conditions.

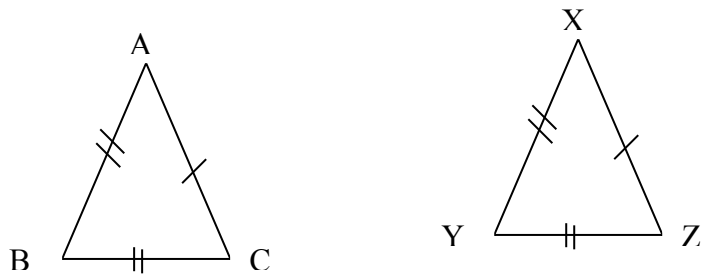

Fig. 1.20

- (ii) If two sides of one triangle DEF are equal to two sides of another triangle PQR, and the angles included by those two pairs of equal sides are equal then the triangles are congruent

Thus, Δ s DEF and PQR are congruent (SAS) or angle DEF and Δ PQR are congruent (SAS). It should be noted that, here (SAS) cannot be written as ASS or SSA because the angle has to be the included angle by the two sides i.e. SAS.

Figure 1.21 illustrate these conditions

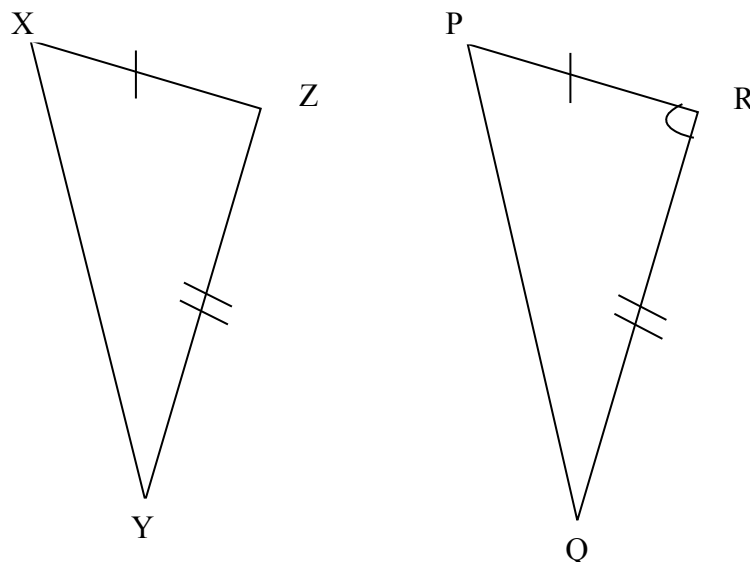

Fig. 1.21

- iii) If two angles of one triangle ABC equals two angles of another JKL and any one side of triangle ABC equals the corresponding side of JKL, then the two triangles are congruent.

This condition is represented by angle, angle side (AAS) or side, (SAA) or even (ASA), because the corresponding sides could be included. We often write it thus, Δs ABC are congruent (AAS) or (SAA) or ΔABC and JKL are congruent JKL (SAA) or (AAS) the equal sides must be corresponding i.e. face equal angles. Figure 1.22 illustrates these conditions

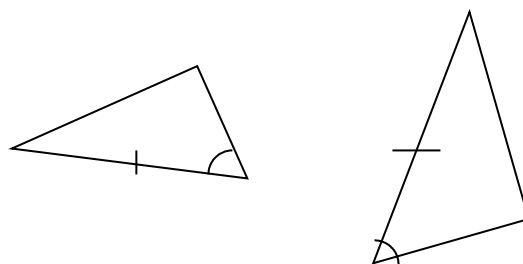

Fig 1.22

- iv) If two right angled triangles have their hypotenuses equal and also one other side of one triangle equal to one other side of the other triangle, then angle s ABC are congruent (RHS)

This condition involves rt \angle , hypotenuse, side- RHS. (See fig. 1.23 for illustration)

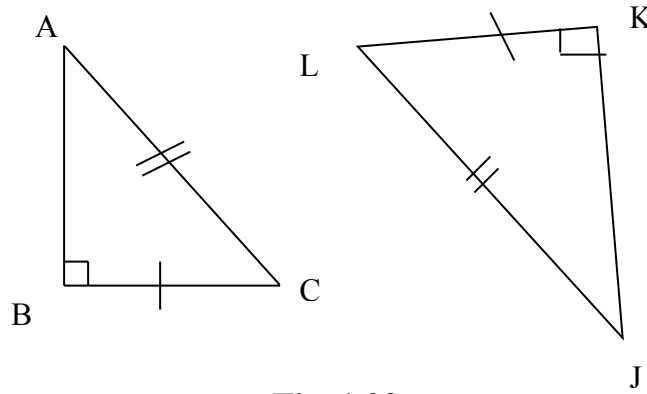

Fig. 1.23

Once any of the four conditions listed above is true of any pair of triangles, the triangles are congruent i.e. they are equal in all respects. Conditions for congruency are useful in proving sides/ angles of triangles equal.

Example 1.8.1

ABCD is a square and QCD is an equilateral triangle and inside the square. Show that $BQ = AQ$.

Solution

See fig. 1.2.4

Given: - a square ABCD and an equilateral ΔDCQ drawn inside it.

Required: - To prove $AQ = BQ$

Poof: - Consider Δ s ABQ and BCQ

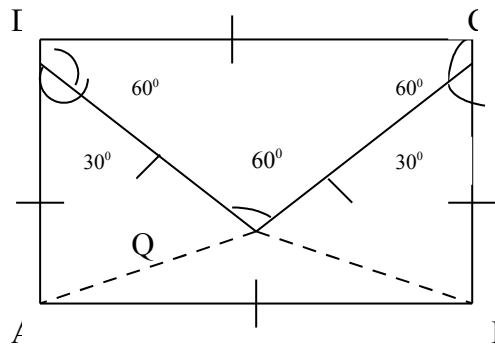

Fig. 1.24

$AD = BC$, sides of a square

$DQ = CQ$ sides of an equilateral triangle

$\angle ADQ = 90^\circ - 60^\circ = 30^\circ = \angle BCQ$

Therefore Δ s ADQ are congruent (SAS)

BCQ

Then, $AQ = BQ$

Example 1.8.2

AB and XY are equal chords of a circle, centre O, prove that $\angle OAB = \angle OXY$

Solution

See fig 8.25

Given: 2 equal chords AB and XY

Centre O

Required: - to prove $\angle OAB = \angle OXY$

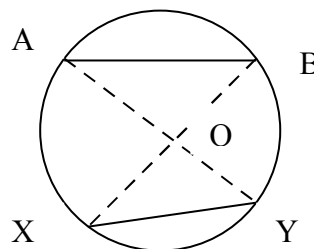

Fig 1.25

Construction needed: - Join O to A, B, X, Y.

Proof: Consider $\triangle AOB$ and $\triangle XOY$

$AB = XY$ given

$AO = XO$ radii of one circle

And $BO = YO$ radii of one circle

Therefore $\triangle AOB$ and $\triangle XOY$ are congruent (SSS)

Hence, $\angle OAB = \angle OXY$

i.e. $\angle OAB = \angle OXY$

SELF ASSESSMENT EXERCISE 3

ABCD is a square. M is the mid-point of AB. Prove that $MD = MC$

3.7 Similar Triangles

When the angles of one triangle are equal to the angles of another triangle the two triangles are said to be similar i.e. their shapes are alike. This does not mean that their sides are equal too, or that they are congruent, rather the ratios of their corresponding sides are equal. The corresponding sides are sides opposite equal angles. e.g. If $\triangle ABC$ and $\triangle XYZ$ are similar, (see figure 1.26), then $\angle A = \angle X$, $\angle B = \angle Y$ and $\angle C = \angle Z$ also the ratio of the corresponding sides are equal

$$\text{i.e. } \frac{AB}{XY} = \frac{AC}{XZ} = \frac{BC}{ZY}$$

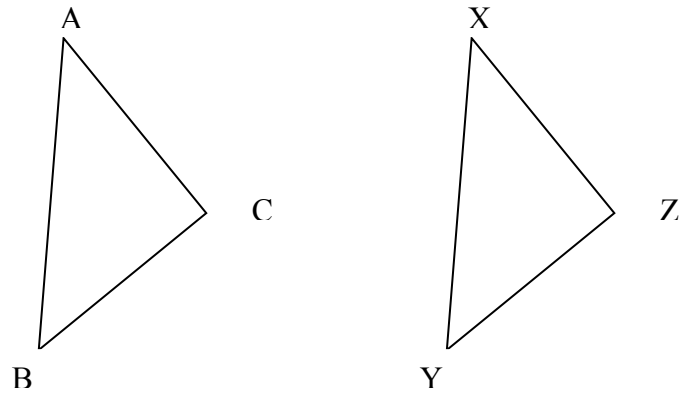
**Fig. 1.26**

In similar vein, if two triangles PQR and XYZ are similar (fig 8.27) the ratio of their areas is equal to the ratio of the squares of the corresponding sides.

$$\frac{\text{Area of PQR}}{\text{Area of XYZ}} = \frac{PQ^2}{XY^2} = \frac{PR^2}{XZ^2} = \frac{QR^2}{YZ^2}$$

**Fig. 1.27**

For similar triangles students should take note of the following points. That two triangles are similar:

- i) If 2 angles of one triangle are equal to 2 angles of the other triangle.
- ii) If the ratios of their corresponding sides are equal
- iii) If the ratio of the areas of the triangles is equal to the ratio of the squares of the corresponding sides.

Similar triangles are also equiangular triangles

Example 1.9.1

Show that triangles DHG and DEF are similar in the fig below.

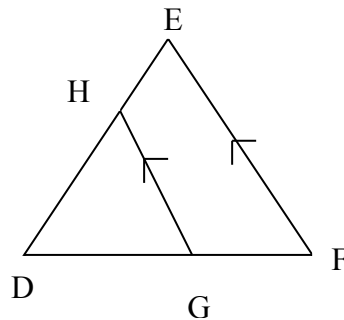

Fig. 1.28

Solution

Given: - The diagram in which $HG \parallel FE$

Required: - To prove that $\triangle DHG$ is similar to $\triangle DEF$

Proof: compare $\triangle DEF$ and $\triangle DHG$

$\angle DEF = \angle DHG$. Corr $\angle s$

Similarly $\angle DFE = \angle DGH$ corr $\angle s$

and $\angle D$ is common to both triangles

Thus, the 3 angles of $\triangle DHG$ are equal to the 3 angles of $\triangle DFE$

Hence, $\triangle DEF$ are similar $\triangle DHG$.

3.8 Pythagoras Theorem

This states that, in a right angled triangle, the square of the hypotenuse is equal to the sum of the squares of the other two sides. Applying the usual notation, i.e. $a^2 = b^2 + c^2$

4.0 CONCLUSION

In this unit, you have learnt that geometry has to do with the study of linear measurement and angular or rotational measurements. By extension, you also learnt that geometry also studies shapes and figures bounded by lines and curves. We then went ahead to discuss different kinds of line and angles and dealt extensively with the kinds and properties of triangles, giving some simple problems and their solutions.

5.0 SUMMARY

In this unit, you have been treated to the following:

- Geometry is a branch of mathematics that deals with the study of linear measurement and angular or rotational measurement
- It also deals with the study of shapes and figures bounded by lines and curves.
- Geometry has a wide range of application in the physical world e.g. engineering, survey, sciences, to mention a few.
- Different kinds of lines exist vertical, horizontal, oblique, parallel, and transversal.
- Angle is a measure of rotation or turning and its measured in degree.
- Different kinds of angles do exist e.g. acute, obtuse, right angle, reflex, adjacent, straight, angles.
- We could also have supplementary and complementary angles.
- A triangle is a closed three-sided figure with three angles.
- There are different kinds of triangles; such as equilateral, isosceles, and scalene triangles.
- Two or more triangles are said to be congruent when they are equal in all respects.
- Two or more triangles are said to be similar not congruent, when their shapes are alike.

6.0 TUTOR-MARKED ASSIGNMENT

1.
 - a) What do you mean by Geometry?
 - b) With the aid of suitable diagrams describe the following kinds of lines.
 - i) Vertical line (ii) horizontal line (iii) parallel line (iv) transversal line (v) oblique line.
2.
 - a) Define an angle. Give 3 examples with illustration.
 - b) Mention and explain 3 kinds of triangles.
 - c) Outline any four conditions for congruency in triangles.
3.
 - a) PQ is a chord of a circle, center O. If N is a point on the chord such that ON is perpendicular to PQ, prove that PN = NQ.
 - b) ABCD is a square and OCD is an equilateral triangle drawn inside the square. Prove that triangles ADB and CBD are congruent.

7.0 REFERENCES/FURTHER READINGS

Olayanju, S. O. and Oyewobi, G. O. (1998). *Geometrical Shapes and Measurement*. Lagos SIBIS Bentures; 40.

Godswill, Osbioma et al (2004). *Science Teachers Association of Nigeria Mathematics for Junior Secondary School 2*. Ibadan University Press.

David-Osuagwu, M. N. Chinwa A. Onyeozili (2004). *New School Mathematics for Senior Secondary Schools*. Africana First Publishers 200-240.

UNIT 4 SOLIDS AND 3- DIMENSIONAL SHAPES

CONTENTS

- 1.0 Introduction
- 2.0 Objectives
- 3.0 Main Content
 - 3.1 Kinds and Properties of Solid Figure or Shapes
 - 3.2 Properties of Solid Shapes
 - 3.3 Modeling of Solid Shapes
- 4.0 Conclusion
- 5.0 Summary
- 6.0 Tutor-Marked Assignment
- 7.0 References/Further Readings

1.0 INTRODUCTION

In your secondary school days or thereabout, you might have been taught different kinds of shapes by your mathematics teacher(s). In this unit, you are still going to learn about the shapes of solids or shapes of 3 dimensional solids. Ordinarily, the study of shapes of figures comes under the branch of mathematics called geometry. Here, shapes of objects or figures such as cuboids, cubes, cylinders spheres, cones and prisms would be examined Particular emphasis shall be placed on the properties of these figures.

2.0 OBJECTIVES

By the end of this unit, students should be able to:

- identify solid figures
- name simple solids shapes
- outline the properties of some solid shapes
- make simple solid geometrical shapes.

3.0 MAIN CONTENT

3.1 Kinds and Properties of Solid Figures or Shapes

In mathematical enterprises, we encounter a number of solid figures or shapes. In fact they come in their various forms. In this section of this unit, you would be exposed to three – dimensional solids or shapes. Particular emphasis shall be placed on their properties and what differentiate these kinds of shapes or objects from plane objects.

Generally, solids are hard objects or figures. They have the following properties.

- (i) They conform to various shapes or possess a number of surfaces
- (ii) They are dimensional
- (iii) They can not be squeezed
- (iv) They are not fluid – like

Examples of solid objects include, stone, cube, cone, cuboids, cylinder, blocks, tins of different shapes etc. solids are different from plane objects in that the latter is flat, two – dimensional and could form part of a solid. Examples of plane objects include the surface of flat table or rectangular floor of a room, triangle, square, trapezium or a circle. In dealing with any of these plane figures or shapes various forms of measurements of their dimensions can be carried out. For example let us consider what kinds of measurement of dimensions of a square can be carried out in order to discover its properties. Such measurement as measurement of all its four sides, the length of its diagonal, measurement of the square corners or the four interior angles, lines of symmetry etc.

In dealing with geometrical shapes, such properties as faces, vertices and edges are often given consideration. Face refers to the front or surface of the object. The vertex are the farthest points of such solid object or the point(s) at which two lines meet, to form an angle or the point that is opposite the base of a shape. Edge refers to the sharpest sides of a solid shape. Figure 2.1 (i) and (ii) illustrate these properties for a cube and a Cuboids.

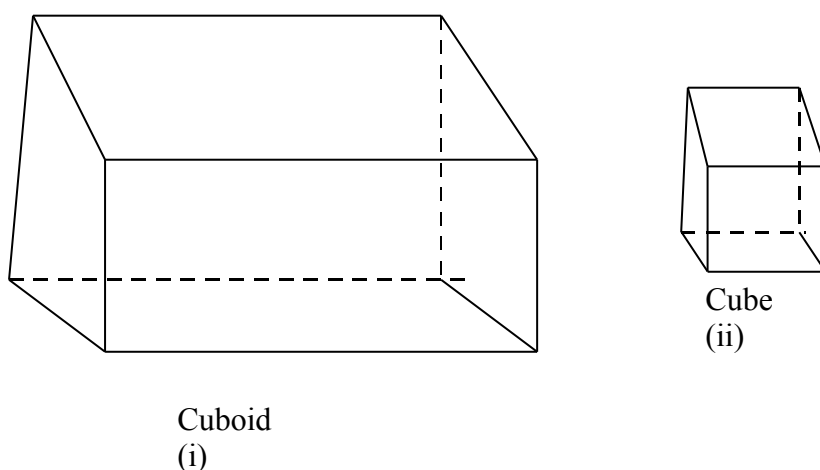

Fig. 2.1

3.2 Properties of Solid Shapes

Let us examine the properties of some of the solid shapes mention in section 3.1 one after the other.

(i) Cuboid

A cuboids is a 3 – dimensional solid with six rectangular sides. They are shapes like carton of chalk, wooden boxes, cement blocks, match boxes, textbooks, empty packet of sugar. A cuboid has six faces, 8 vertices and twelve edges.

(ii) Cube

Cube resembles cuboid in all respects except that cuboid has longer dimensions than cube. In fact, cuboid derive their nomenclature from cube i.e. shape like cube. They are solid objects having six equal faces, twelve edges and eight vertices. Examples of cube are cube of sugar, maggi cube, dice, carton of larger beer etc.

(iii) Cylinders

Cylinders are round objects having round faces (circular faces) and flat tops. Examples of cylinders include tin of milk, a lead pencil, a water pipe, a drum, a cylindrical wood etc.

(iv) Rectangular Based Pyramid

This is an object that has eight edges, five faces, five vertices and a rectangular base.

(v) Rectangular Prism

A prism is a solid shape with a uniform cross-section. Therefore, rectangular prism is an object having rectangle as its cross section. Similarly, the cross-section is a square; the cross section of a cylinder, triangular prism and hexagonal prism are cone, triangle and hexagon respectively.

(vi) Spheres

Spheres are solid shapes that look like the shapes of triangles, balloons, tomatoes and water pots.

(vii) Cones

A cone is a circular based object having only one vertex, one circular edge and two faces. It can be referred to as a circular pyramid. Examples include, the sharpened end of a drawing pencil, a kerosene funnel, and a top of salt measure.

(viii) Tetrahedron

It is a solid object having four faces, six edges and four vertices.

Figures 2.2 (i) – (vii) illustrate some of the solid shapes that we have discussed so far.

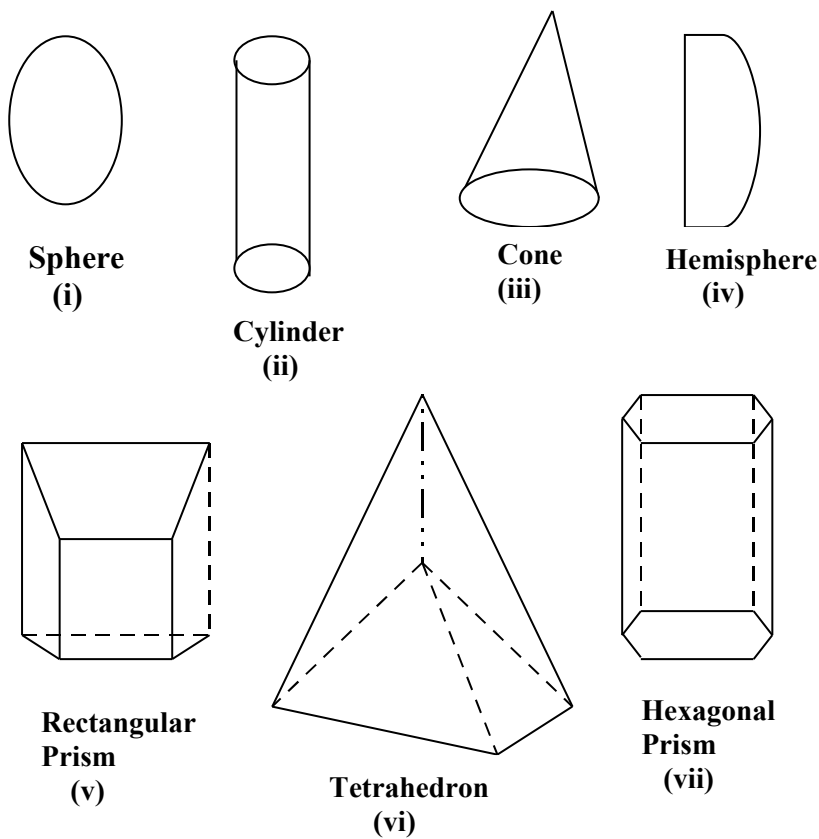

Fig. 2.2 Chart Showing Some Solid Shapes

SELF ASSESSMENT EXERCISE 1

Draw and list the properties of the following solid shapes.

- (i) Cuboids (ii) Cone (iii) Cylinder
 (iv) a tetrahedron.

3.3 Modeling of Solid Shapes

This section is dedicated to making models of some of the solid shapes that were discussed in the preceding section of this unit. In making such models such materials as used calendar, cello tapes, gum, pair of scissors, cardboards, wood, glue and nails are required to make models of these solid shapes or figures. Making models as teachers which many, if not all students offering this course are, would further enhance better understanding of the properties of these shapes. This would also assist learners especially when they come to the problem solving aspect of these solids. The separation or emergence of the given solid is called 'Nets of a solid. Figure 2.3 (i) – (vii) illustrate net of solids for different kinds of shapes.

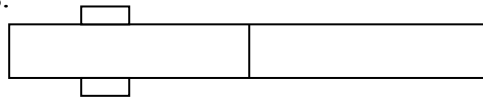

(i) Net of a cube

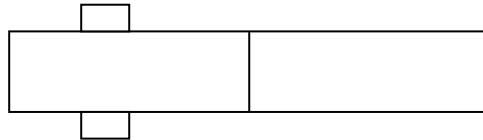

(ii) Net of a cuboid

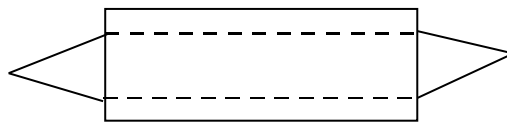

(iii) Net of a triangular prism

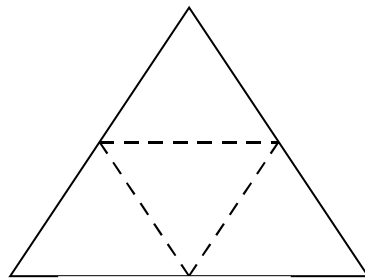

(iv) Net of triangular

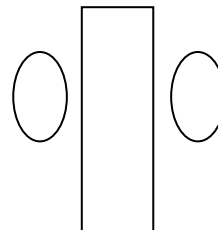

(vi) Net of cylinder

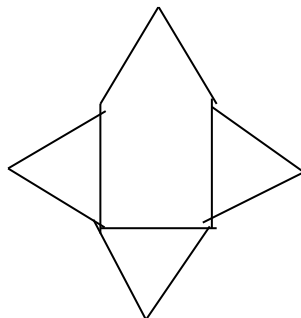

(v) Net of a square based

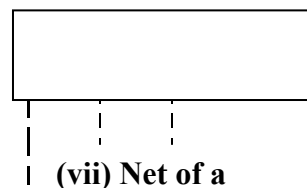

(vii) Net of a match box

Fig. 2.3 Chart Showing the Nets Solids Shapes

SELF ASSESSMENT EXERCISE 2

Given a cardboard sheet, cellotape and a pair of scissors, explain how you would make (i) a cube (ii) a square based pyramid

4.0 CONCLUSION

In this unit you have learnt about solids or shapes of solids, specifically the properties of some solids such as sphere, cone, pyramids to mention a few were discussed. Most especially three main properties were used to describe the nature of these shapes to give a clear understanding of what they are. You were also treated to how some of these shapes could be modeled given simple locally available materials.

5.0 SUMMARY

In this unit, you have learnt that:

- We come into contact with a number of shapes in mathematics.
- Different solids possess different properties, which are peculiar to each of them.
- Majorly, three main properties are used to identify different kinds of solid figures
- These properties include, faces, vertices and edges.
- Some of these shapes can be modeled using certain locally available materials such as cellotape, scissors, cardboards etc.

6.0 TUTOR-MARKED ASSIGNMENT

1. Outline the properties of the following solids (a) Cone (b) Cuboid (c) cylinder (d) rectangular based pyramid (e) tetrahedron.
2. Draw diagrams to show each of the solids in (a) – (e) above.

7.0 REFERENCES/FURTHER READINGS

David Osuagun, M. N, Anemelu, C Onyeozili, I. (2004). *New School Mathematics for Senior Secodnary Schools*. Akure, Africana First Publishers.

Olayanju S. O. & Olosunde, G. R. (2001). *Shapes' Measurement for Schools and College*. Lagos, Sibis Ventures.

UNIT 5 PLANE SHAPES AND THEIR PROPERTIES

CONTENTS

- 1.0 Introduction
- 2.0 Objectives
- 3.0 Main Content
 - 3.1 Meaning and Scope of Plane Shapes
 - 3.2 Circle
 - 3.3 Polygon
 - 3.4 Quadrilateral
 - 3.5 Parallelogram
 - 3.6 Trapezium
 - 3.7 Rectangle
 - 3.8 Rhombus
 - 3.9 Kite
- 4.0 Conclusion
- 5.0 Summary
- 6.0 Tutor-Marked Assignment
- 7.0 References/Further Readings

1.0 INTRODUCTION

In Module 2 Unit 1, a typical example of plane figure i.e. triangle was extensively discussed. In the proceeding unit you also learnt about solids or three dimensional shapes. Here, we are going to concentrate our effort on discussing other plane figures or shapes excluding triangle which has been discussed earlier. In specific terms, the properties and lends of these plane shapes shall be dealt with.

2.0 OBJECTIVES

By the time students go through this unit, they should be able to:

- identify some plane shapes
- get familiar with different kinds and properties of plane shapes
- draw different kinds of plane shapes.

3.0 MAIN CONTENT

3.1 Meaning and Scope of Plane Shapes

Generally, plane shapes are flat figures which one sometimes called two – dimensional (2-D) shapes. Examples of materials in this category include table tops, chalkboard, cardboards, floor tiles, ceiling board, circular objects etc. All these objects have flat shapes known as 2 –

dimensional shapes. Geometrical shapes of interests which we are going to deal with in this unit are circle, polygon, quadrilateral. One other example, which we have treated extensively, is triangle (see unit 1).

3.2 Circle

By definition, a circle is the locus of (or the path traced by) a moving point maintaining equal distance from a fixed point. The distance round this path so traced is called the Circumference of the circle. A circle has other properties which are briefly explained below.

- (i) **Radius:** -This is the line drawn from the centre of a circle to a point on the circumference.
- (ii) **Diameter:** - This is line drawn across a circle through the centre. The diameter bisects a circle into two equal halves. Each part is a semi – circle.
- (iii) **Arc:** - This refers to a part of the circumference of a circle. An arc could be minor or major depending on the size of the arc. Thus, a minor arc is less than half of the circumference of a circle, while a major arc is more than or greater than half of the circumference of a circle.
- (iv) **Chord:** - This is a straight line that touches any two points on the circumference of a circle. A chord divides a circle into two parts. Each part is called a segment. The smaller portion is known as minor segment while the bigger one is known as major segment.
- (v) **Sector:** - A sector of a circle is a plane figure bounded by two radii (plural of radius) and an arc. A sector could be major or minor. A sector is major if it contains a major arc and minor if it contains a minor arc.
- (vi) **Annulus:** - this is a special circle that has two circular surfaces. A typical example of annulus is a pipe. Fig 3.1 illustrates all the above properties of circles.

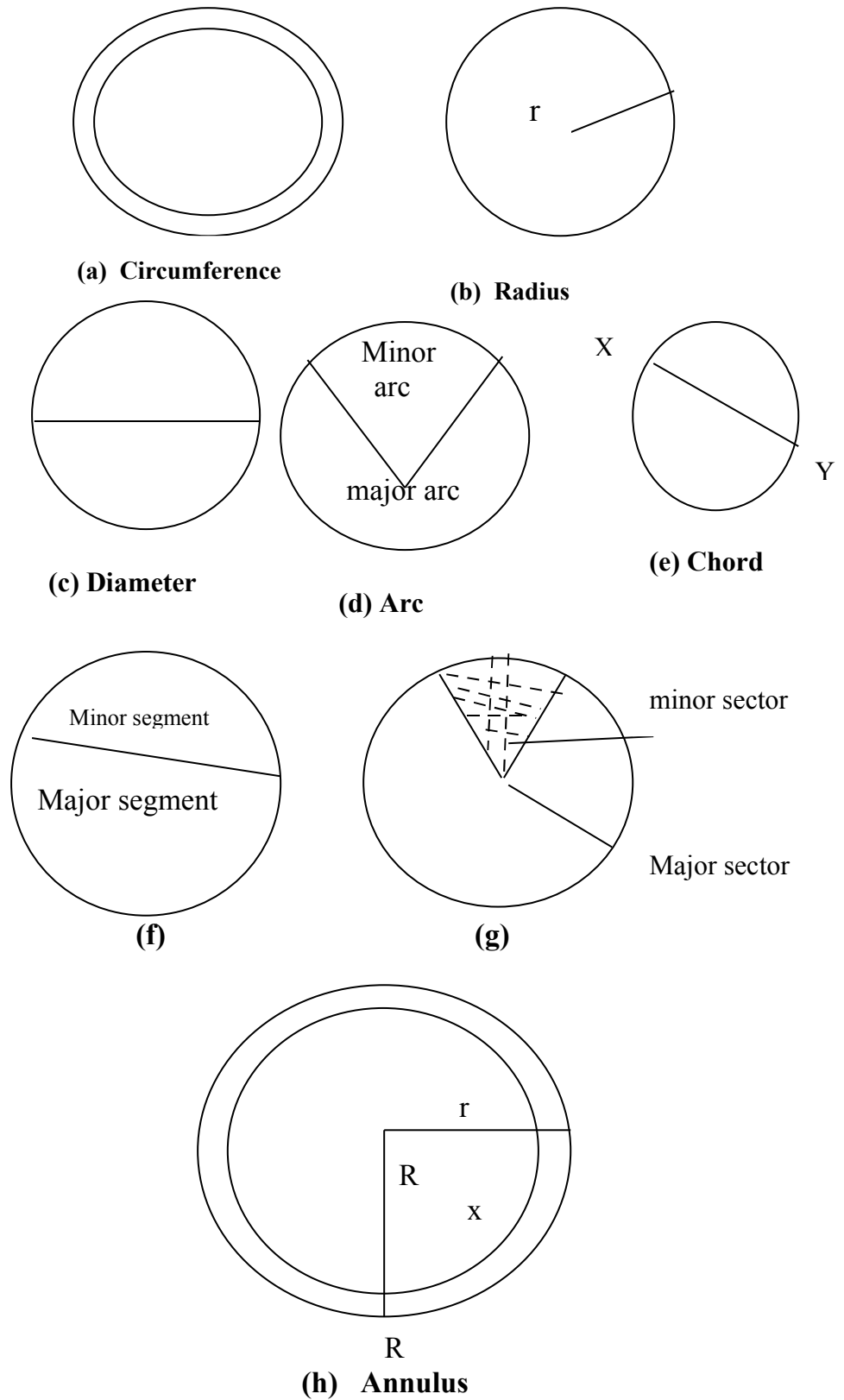

Fig. 3.1 Chart Showing Parts of a Circle

3.3 Polygon

A polygon is any plane shape bounded by straight line segment. The line segment must not cross one another so that a polygon has only interior angles. In addition, two polygons cannot be joined together as a vertex to make any polygon. A polygon is **REGULAR**, if its sides and angles are equal. It is **RENTRANT** if at least one interior angle is greater than 180° and **CONVEX**, if every interior angle is not up to 180° . Figure 3.2 (a) – (c) illustrates some examples of polygons.

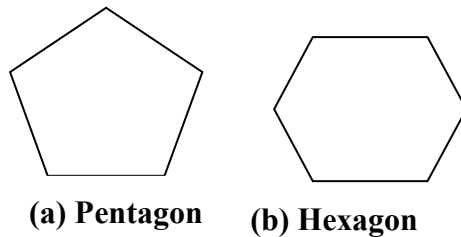

Fig. 3.2

3.4 Quadrilateral

A quadrilateral is a plane shape enclosed by four line segments. Generally, quadrilateral is a four sided solid polygon.

Examples of quadrilateral are the parallelogram, rhombus, and kite. Others include rectangle, squares and trapezia.

SELF ASSESSMENT EXERCISE 1

1. Define a circle.
2. Outline all the properties of a circle.

Having defined what quadrilaterals are, let us now discuss in more details the properties of each of these shapes / figures for better understanding of what each of the shapes represent.

3.5 The Parallelogram

A parallelogram is a quadrilateral (four-sided figure) made up of both pairs of opposite sides that are parallel. Figure 3.3 illustrates a parallelogram.

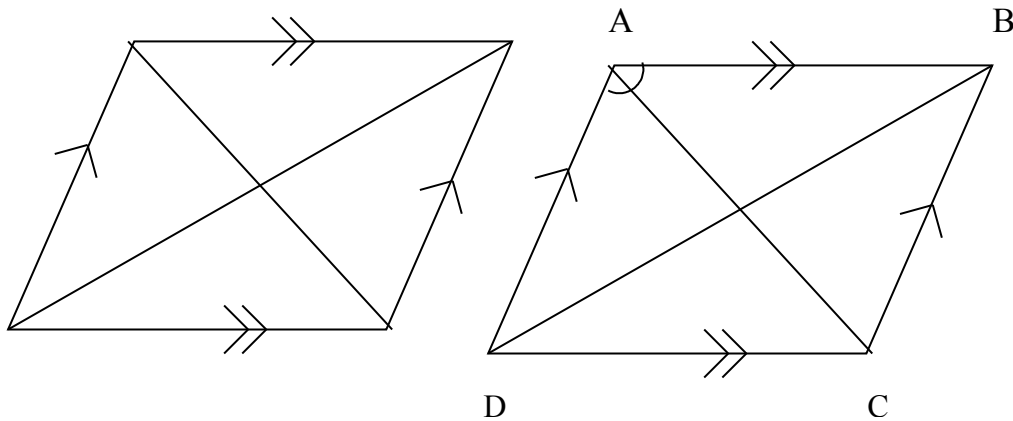

Fig. 3.3

In parallelograms, the following properties also stand out

- (a) The opposite sides are equal
- (b) The opposite sides are equal in length and they are parallel.
- (c) The diagonals bisect each other.
- (d) Each diagonal bisects the parallelogram into congruent triangles.
- (e) The allied angles are supplementary i.e. $\angle A + \angle D = 180^\circ$ $\angle B + \angle C = 180^\circ$, $\angle C + \angle D = 180^\circ$.

3.6 Trapezium

A trapezium of a quadrilateral having a pair of equal opposite sides parallel. If the other pair is equal, then the figure may be called isosceles trapezium. Figure 3.4 illustrates what a trapezium is. Knowledge of trapezia is useful in dealing with cross – sections of cones, pyramids, prisms and other 3 – dimensional objects.

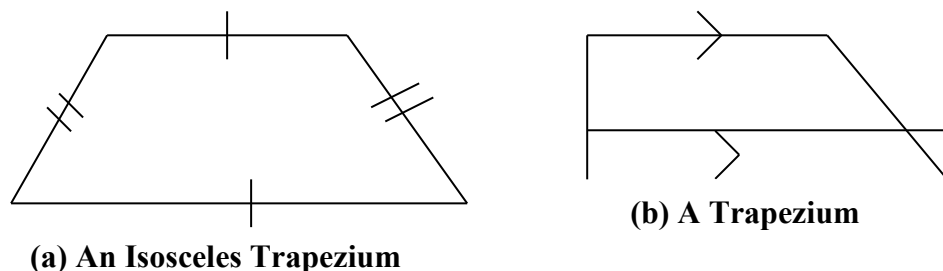

(a) An Isosceles Trapezium **(b) A Trapezium**

Fig. 3.4

Special kinds of Parallelogram

There are three special kinds of parallelograms. These are rhombus, rectangle and square.

3.7 Square

A square is a parallelogram, which has four equal sides. A square has the following angles:

- (i) The angles are all right angles
- (ii) The sides are all equal
- (iii) The diagonals are equal
- (iv) The diagonals bisect each other at right angles
- (v) The diagonals bisect the angles.

In fig 3.5 ABCD is a square

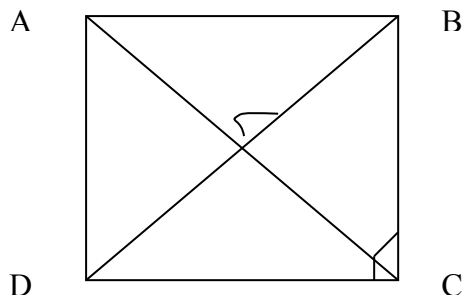

Fig. 3.5

$\angle A = \angle B = \angle C = \angle D = 90^\circ$ and $AB = BC = CD = DA$

Hence, $\angle AOB = \angle BOC = 90^\circ$ and $\angle ADB = \angle CDB$

Also, $AC = BD$ and $AC \perp BD$,

$\angle CBD = \angle ABD = \angle BAC = \angle DAC = \angle BCA = \angle DCA$

3.8 Rectangle

A rectangle is a parallelogram in which all the four angles are right angles. A rectangle has the following properties.

- (i) The angles are right angles
- (ii) The diagonals are equal in length

In figure 3.6 PQRS is a rectangle, where

$PQ = SR$ and $PS = QR$

$\angle P = \angle Q = \angle R = \angle S = 90^\circ$

$PR = QS$ and $QO = SO$, $PO = RO$

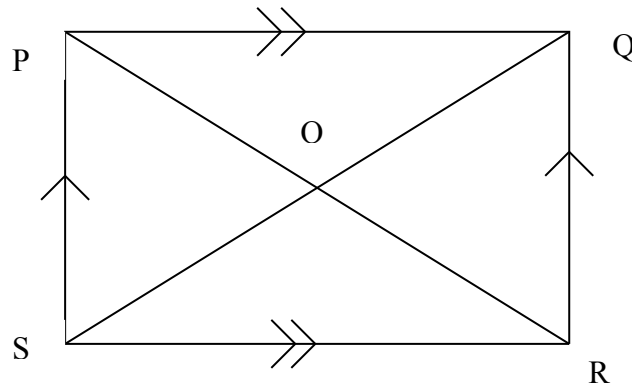

Fig. 3.6

3.9 Rhombus

A rhombus is a parallelogram in which a pair of adjacent sides are equal. A rhombus has the following properties.

- (i) The sides are all equal
- (ii) The diagonals bisect each other at right angles
- (iii) The diagonals bisect the angles.

In figure 3.7 ABCD is a rhombus then $AB = BC = CD = DA$, $AO = CO$ and $BO = DO$.

Also $\angle AOB = \angle BOC = \angle COD = \angle DOA = 90^\circ$

However, students should note these different kinds of parallelograms and their separate properties. This is necessary because the properties are very useful in solving problems. First of all, they are all parallelograms and therefore discussed in this unit. In addition, each of these examples has its own separate properties, which distinguishes each of them from other parallelograms. It is essential for students to know the separate properties as well as the common properties. Once, you have understood this well, there will be no problem dealing with parallelograms. If these figures are defined as parallelograms there is a need to list all the properties of a parallelogram. First and add also the specific properties of the figure.

SELF ASSESSMENT EXERCISE 2

1. What are the differences between a trapezium and a parallelogram?
2. List the properties of a parallelogram and give three examples of special parallelograms.

3.10 Kite

Kite is a quadrilateral with two pairs of equal adjacent sides. It should be noted that in a kite the opposite sides are not equal. Although a kite is not a regular quadrilateral because neither the angles nor the sides are equal; it can be made somewhat regular by drawing the correct diagonal joining the equal angles at B and D, thereby creating two isosceles triangles ABD and CBD. See figure 3.8

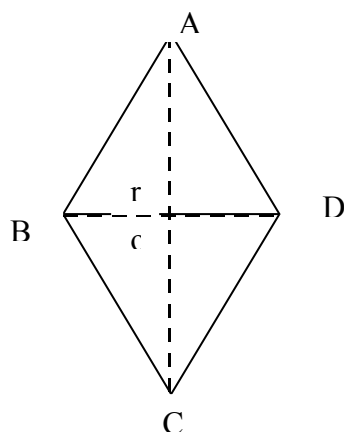

Fig. 3.7 A Kite

Generally, a kite has the following properties:

- (i) It has 2 pairs of equal adjacent sides $AB = AD$ and $CB = CD$
- (ii) The diagonal BD and AC meet each other at right angles i.e. $\angle AOB = 90^\circ$ etc.
- (iii) The correct diagonal cuts it into two isosceles Δ s. Here BD cuts the kite into two isosceles triangle BAD and BCD.

SELF ASSESSMENT EXERCISE 3

1. Why is a kite not a regular quadrilateral?
2. How can you make a kite conform to quadrilateral shapes?

4.0 CONCLUSION

In this unit, you have learnt about various kinds and properties of plane shapes. Specifically you have learnt about circles, polygon, quadrilateral, parallelogram and a kite. Efforts were made to emphasize the general and specific properties of these plane figures and the importance of these properties in problem solving. Application of the knowledge about these properties in solving problems shall be dealt with in subsequent units in this course.

5.0 SUMMARY

Students have been exposed to the following in this unit:

- Plane figures / shapes and flat figures which are called 2 – dimensional (2-D) shapes.
- A plane shape bounded by three or more straight lines is called a polygon.
- Any polygon whose sides are all equal to each other is called a regular polygon; otherwise it is an irregular polygon.
- A four –sided closed figure is called quadrilateral. There are different kinds of quadrilaterals, namely a parallelogram, a kite, a trapezium and other irregular quadrilaterals.
- A parallelogram is a quadrilateral with the opposite sides parallel
- A rectangle is a parallelogram in which all the four angles are right angles and two opposite sides equal.
- A rhombus is a parallelogram in which a pair of adjacent sides are equal
- A kite is a quadrilateral with two pairs of equal adjacent sides.

6.0 TUTOR-MARKED ASSIGNMENT

1. Define (i) a polygon (ii) a quadrilateral (iii) a parallelogram (iv) a trapezium (v) a square (vi) a rectangle (vii) a kite (viii) a rhombus.
2. Outline the properties of (a) Rhombus (b) a square (c) a kite (d) a polygon (e) a quadrilateral

7.0 REFERENCES/FURTHER READINGS

David – Osuagwu, M. N. (2004). *New School Mathematics for Senior Secondary Schools*. Akure Africana First Publishes Ltd. 238 – 241.

Obioma, G. et al (2003). *Man Mathematics for Junior Secondary Schools 2*. Ibadan, University Press PLC 128 – 135.

MODULE 3

Unit 1	Perimeter of Plane Shapes
Unit 2	Areas
Unit 3	Surface Areas of Solid Object (Three Dimensional Objects)
Unit 4	Volume of Simple Solids
Unit 5	Simple Geometric Constructions

UNIT 1 PERIMETER OF PLANE SHAPES**CONTENTS**

1.0	Introduction
2.0	Objectives
3.0	Main Content
3.1	Meaning and Scope of Perimeter
3.2	Parallelogram
3.3	Triangle
3.4	Rectangle
3.5	Polygon
3.5.1	Interior Angles of a Polygon
3.5.2	Determination of the Number of Sides of a Polygon
3.6	Circle
3.6.1	Length of an Arc
3.6.2	Perimeter of a Segment of a Circle
4.0	Conclusion
5.0	Summary
6.0	Tutor-Marked Assignment
7.0	References/Further Readings

1.0 INTRODUCTION

In unit three of this Module, we dealt extensively with the various kinds and properties of plane shapes. Here, we shall see how our knowledge about the properties of these plane shapes can be used to solve problems that both on them with particular reference to the perimeter of these plane shapes.

2.0 OBJECTIVES

By the end of this unit, students should be able to:

- define the word “perimeter” of an object/ figure
- write the correct formula for calculating the perimeter of a given plane shape
- calculate the perimeter of some plane shapes e.g triangle, rectangle polygon e.t.c.

3.0 MAIN CONTENT

3.1 Meaning of and Scope of Perimeter

The word perimeter simply means the distance round an object. So, the perimeter of a plane object refers to the distance round the plane object. This is obtained by summing up the lengths of the sections into which the edge can be divided. Let’s now look at each of the plane shapes discussed in the preceding chapter with a view to determining their perimeters.

3.2 Parallelogram

Considering the parallelogram PQRS below, the perimeter is $x + x + y + y = 2x + 2y = 2(x + y)$.

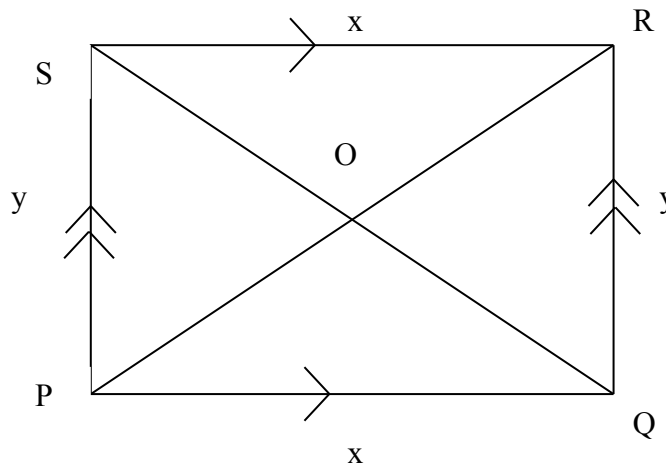

SELF ASSESSMENT EXERCISE 1

Find the perimeter of the parallelograms provided below.

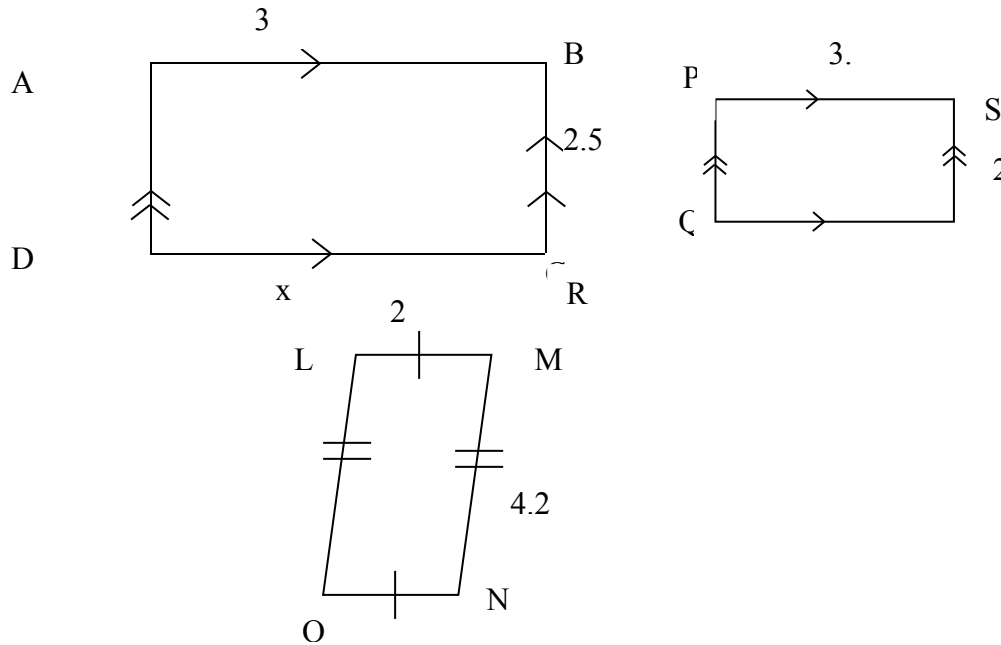

Solutions

- (a) $AB = DC = x$
 And $AD = BC = y$
 Perimeter of ABCD = $2(x+y)$
 $= 2(3+2.5)$
 $= 11\text{cm.}$

- (b) $PS = QR = a = 3.8\text{cm}$
 $PQ = SR = b = 2\text{cm}$
 Perimeter of PQRS = $2(a + b)$
 $= 2(3.8+2)$
 $= 11.6\text{cm}$

- (c) $LO = MN = p = 4.2\text{cm}$
 And $LM = ON = q = 2\text{cm}$
 Perimeter = $2(p+q)$
 $= 2(4.2+ 2)$
 $= 12.4\text{cm}$

3.3 Triangle

For a triangle ABC, the perimeter is obtained by adding the lengths of the three sides (edges) $a + b + c$. (See figure 4.2.)

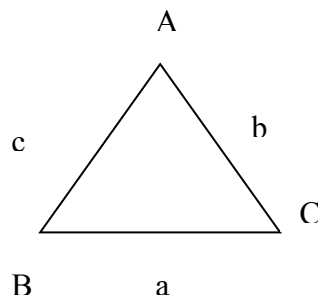
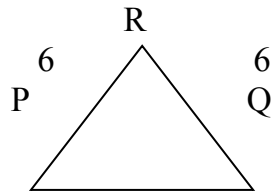

Fig. 4.2

Example 4.4.1

Find the perimeter of the ΔPQR , given that $PQ=9\text{cm}$, $QR=PR=6\text{cm}$.

Solution

Perimeter= $6+9+6=21\text{cm}$.

SELF ASSESSMENT EXERCISE 2

Calculate the perimeter of a ΔABC where $a=10\text{cm}$, $b=8\text{cm}$ and $c=7\text{cm}$.

3.4 Rectangle

In the same vein, the perimeter of a rectangle is determined by calculating the length of the distance round the figure. For example, if x is the length and b is the height of a rectangle ABCD, then the perimeter of the rectangle is $x+b+x+b$ which is equal to $2(x+b)$.

This means that:

$$\text{Perimeter of a rectangle} = 2(x+b)$$

Where x and b are the lengths of the 2 equal opposite sides of the rectangular figure. Figure 4.3 illustrates this.

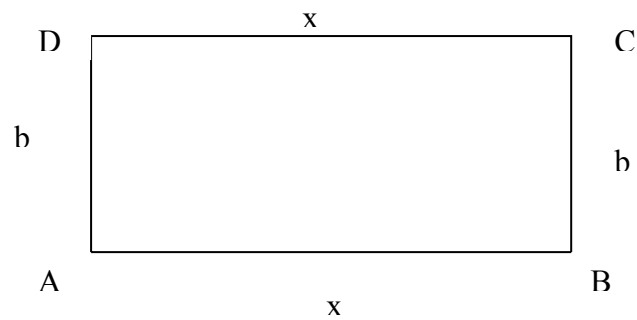
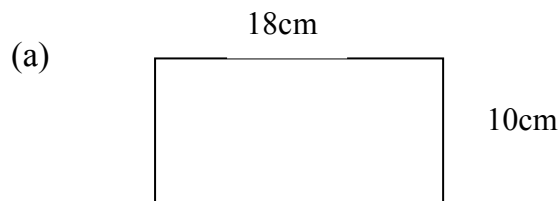

Fig. 4.3

Example 4.5

Find the perimeter of the rectangles with the following dimensions:

- (a) Length, 18cm, width, 10cm
 (b) Length, 10.5cm, width, 4.5cm

Solution

$$\begin{aligned} \text{Perimeter} &= 2(18 + 10) \\ &= 2(28) \\ &= 56\text{cm.} \end{aligned}$$

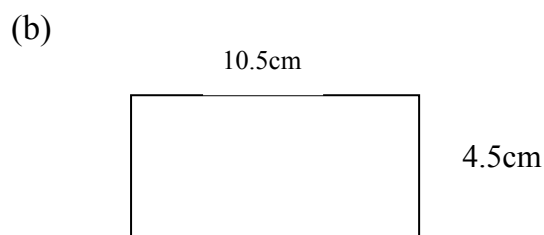

$$\begin{aligned} \text{Perimeter of PQRS} &= 2(10.5 + 4.5) \\ &= 2(15) \\ &= 30\text{cm} \end{aligned}$$

SELF ASSESSMENT EXERCISE 3

The length of a rectangle is three times its breadth. Calculate the breadth if the perimeter is 48cm.

3.5 Polygon

In the preceding unit, it was mentioned that two main types of polygons exist. These, you remember are regular and irregular polygons. In order to determine the perimeter of a polygon whether regular or irregular, students should not forget how to determine the perimeter of such plane shapes such as triangles, square, rectangle etc. which we have treated previously in this unit. This would assist them a great deal in solving similar problems on polygons. In addition, students need to be able to identify the kind of polygon they are dealing with (i.e. whether regular or irregular).

In finding the perimeter of an irregular polygon, you need to measure the lengths of all the sides one after the other, then find the sum. For you to be able to determine the perimeter of a regular polygon, it is much easier. Here, If you know the length of one side, then multiply this length by the number of sides, which the polygon has.

Example 4.7.1

Find the perimeter of the figures below:

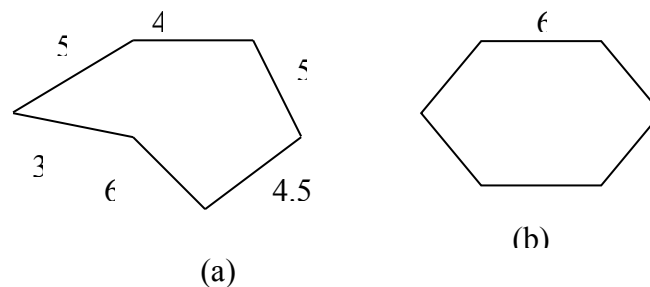

Fig.4.5

- (a) fig. 4.5 is an irregular polygon, hence its perimeter is equal to the sum of the lengths of all the sides.

$$\text{So perimeter} = 5 + 4 + 5 + 3 + 6 + 4.5 = 27.5 \text{ cm}$$

- (b) fig. 4.5(b) is a regular hexagon with six equal sides. Knowing one of the sides then multiplied by the number of sides this gives the perimeter of the figure.

$$\begin{aligned} \text{So perimeter} &= 6(n) \text{ where } n \text{ is the number of sides.} \\ &= 6(6) \text{ cm} = 36 \text{ cm.} \end{aligned}$$

SELF ASSESSMENT EXERCISE 4

Calculate the perimeter of the following figures.

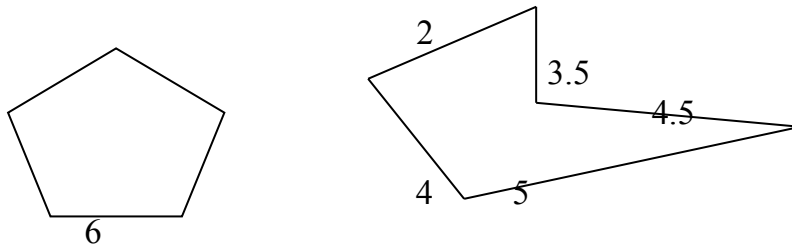
**3.5.1 Interior Angles of a Polygon**

It is possible to determine the sum of the interior angles of a regular polygon. This can be possible if the number of sides is known. For example, to determine the sum of the interior angles of a pentagon, the expression:

$$\begin{aligned} \text{Sum of interior angles of a polygon with } n \text{ sides} &= (n-2) 180^{\circ} \\ \text{So, for a polygon with 5 sides} &= (5-2) 180^{\circ} \\ &= 540^{\circ} \end{aligned}$$

Hence, the sum of the interior angles of a pentagon is 540°

Example 4.7.2

Find the sum of the interior angles of a polygon with 14 sides

Solution

The sum of interior angles of a polygon is given by $(n-2) \times 180^{\circ}$ or $(2n-4)$ right angles.

Where $n=14$

$$\begin{aligned} \text{Then, } (14-2) \times 180^{\circ} &= 12 \times 180^{\circ} \\ &= 2160^{\circ} \end{aligned}$$

So, the sum of interior angles of a 14-sided polygon is 2160°

Students should note the following:

- (i) That if all the sides and all the angles of a polygon are equal, the polygon is said to be regular.
- (ii) an interior angle of a regular polygon is equal to $\frac{n-2 \times 180}{n}$ or $\frac{(2n-4)}{n}$ right angles.

- (iii) The sum of exterior angles of an n -sided polygon is 360° or four right angles.

SELF ASSESSMENT EXERCISE 5

- Find the sum of the interior angles of a 12-sided polygon.
- The sum of six angles of eleven-sided polygon is 1000° . The remaining five angles are equal. Find the size of each of the equal angles.

3.5.2 Determination of the Number of Sides of a Polygon

It is possible to determine the number of sides of a polygon given the sum of the interior angles of such polygon. When this is combined with or equated to the earlier expression used in determining the sum of interior angles of a polygon in section 3.8 (i.e. $(n-2) \times 180^{\circ}$), the number of sides which the polygon has can be easily deduced. Examples 4.7 and 4.8 serve to illustrate this.

Example 4.7.3

Find the number of sides in a polygon, if the sum of the angles is 1800.

Solution

Sum of angles in the polygon = 1800°
 But sum of angles in a polygon = $(n-2) \times 180$
 i.e. $(n-2) \times 180^{\circ} = 1800^{\circ}$
 i.e. $(n-2) = \frac{1800^{\circ}}{180^{\circ}} = 10$
 $n = 10 + 2$
 $= 12$
 Hence, the polygon has 12 sides.

Example 4.7.4

How many sides have a regular polygon if its interior angles are 140° each?

Solution

Each interior angle of an n -sided regular polygon is

$$\frac{(n-2) \times 180}{n}$$

$$\text{i.e. } \frac{n-2 \times 180}{n} = 140^\circ$$

$$(n-2) 180 = 140n$$

$$180n - 360 = 140n$$

$$180n - 140n = 360$$

$$40n = 360$$

$$n = \frac{360}{40} = 9$$

$$40$$

Hence, the polygon has 9 sides (a nonagon).

SELF ASSESSMENT EXERCISE 6

1. Find the number of sides in a polygon, if the sum of its angles is 3060.
2. If the angle of a regular polygon is 162, find the number of sides which the polygon has.

3.6 Circles

In Unit three of this Module, you learnt about a circle and its properties. Then you were exposed to the meaning of sectors and segments. In this section, we shall concentrate more on the perimeter of sectors and segments of a circle. As you have seen under introduction in this unit, perimeter means the distance round an object. So, the perimeter of a sector of a circle is the distance round the sector. This refers to the sum of the lengths of the two radii and the arc, which form the sector. (See figure 4.9). Hence, the perimeter of a sector AOB is the sum of two radii ($2r$) and length of the arc, l , where r , is the radius and l is the length of an arc. Thus, mathematically, expressed:

$$\text{Perimeter of sector AOB} = 2r + l \text{ units}$$

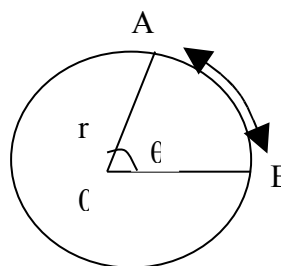
**Fig. 4.8.1**

In a moment, we drive home our

3.6.1 Length of an Arc

shall solve some examples to points.

Remember that in Unit three, you equally learnt about arc(s) in a circle. Here, we shall see how we can determine the length of an arc. However, to determine the length of an arc, the expression $\theta \times 2\pi r/360$ units is normally used. The derivation of this expression is beyond the scope of this course.

In this expression, θ is the angle subtended at the center of the circle and θ is measured in degrees while r , is the radius. If θ is in radians:

$$\text{Length of arc} = \frac{\theta \times 2\pi r}{360} = r\theta$$

Where θ is the radian measured of the angle subtended at the center (it is possible to convert radian to degrees and vice versa. Having known how the length of an arc can be determined, we can now try our hands on some simple examples to buttress our points. (See examples 4.9.1 and 4.9.2).

Example 4.9.1

Find the length of an arc of a circle, radius 5cm which subtends an angle of 50° at the center of the circle.

Solution

Length of arc $\theta \times 2\pi r$ (here θ is in degrees)

We are given $\theta = 50^\circ$ $r = 5\text{cm}$.

See fig 4.9.2

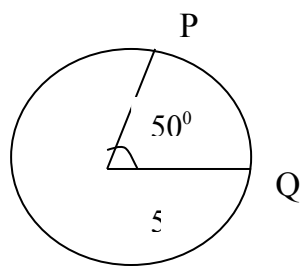

Fig. 4.9.2

Substituting into the expression,

θ

$360 \times 2\pi r$, we have

$$\text{length of arc PQ} = \frac{50 \times 2}{360} \times 5 \times \pi$$

Therefore, length of arc PQ = 25π cm

Students should note that sometimes π can be left in the answer.

Example 4.9.2

Find the length of the major arc, which subtends an angle of circle of radius 5cm (take $\pi = 22/7$).

Solution

Length of major arc = $\theta/360 \times 2\pi r$

Where θ is the angle subtended by the major arc

Here, $\theta = 320^\circ$, $\pi = 22/7$, $r = 5$ cm

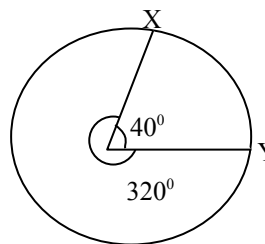

$$\begin{aligned} \text{Therefore, length of arc} \\ &= 320/360 \times 22/7 \times 2 \times 5 \\ &= \frac{32 \times 11 \times 5}{63} \\ &= 27.49\text{cm} \end{aligned}$$

Example 4.9.3

Find the perimeter of the sector of radius 7cm which subtends an angle of (i) 60° (ii) 320° , at the center of the circle (take $\pi = 22/7$).

Solution

(i) Length of arc = $\theta/360 \times 2\pi r$

Where $\theta = 60^\circ$ $r = 7.0\text{cm}$ $\pi = \frac{22}{7}$
 Length of arc = $\frac{60}{360} \times 2 \times \frac{22}{7} \times 7$
 $= \frac{1}{6} \times 2 \times \frac{22}{7} \times 7$
 $= \frac{22}{3} = 7.33\text{cm}$

The perimeter of the sector is $2r + l$, here $r =$ radius, which is 7cm and $l = 7.33\text{cm}$, so the perimeter of the sector which subtends an angle of 60° is.

$(2 \times 7) + 7.33 = 14 + 7.33 = 21.33\text{cm}$.

(ii) Length of arc = $\frac{320}{360} \times 2 \times \frac{22}{7} \times 7$
 $\frac{32}{18} \times 22 = \frac{32 \times 11}{9} = \frac{352}{9}$
 $= 39.1\text{cm}$
 Perimeter of sector is $2r + l$
 $= (7 \times 2) + 39.1\text{cm}$
 $= 14 + 39.1 = 53.1\text{cm}$

3.6.2 Perimeter of a Segment of a Circle

You would recall that the segment of a circle is the portion bounded by a chord and an arc. In figure 4.8.3, it is the shaded portion that is, the segment bounded by arc ACB and chord AB. Before calculating the perimeter of the segment in figure 4.8.3, we need to first calculate the length of the chord (since we already know how to calculate the length of the arc of a circle).

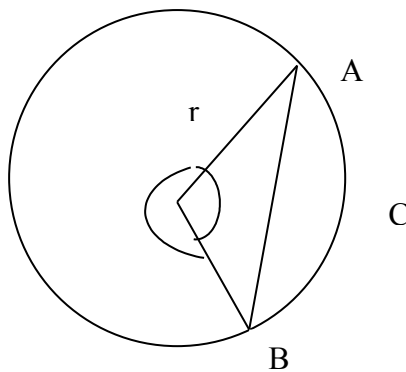
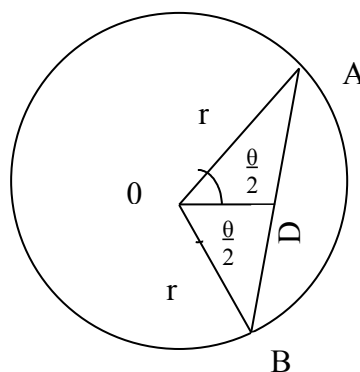

Fig. 4.8.3

In order to find the length of chord AB, the following steps are to be followed.

Therefore $\angle BOD$

$= \angle AOD = \theta/2$



(ii) Using trigonometric ratio:

$$AD/r = \sin \theta/2$$

$$AD = r \sin \theta/2$$

But $AD = DB$ (by construction of the perpendicular bisector)

$$\begin{aligned} \text{Hence, } AB \text{ which is the chord} &= AD + DB \\ &= r \sin \theta/2 + r \sin \theta/2 \\ &= 2r \sin \theta/2 \text{ units} \end{aligned}$$

So, the chord $AB = 2r \sin \theta/2$ units where θ is angle subtended by the chord at the center.

This is the formula for finding the length of any chord of a circle which subtends angle θ at the center of the circle.

Example 4.8.4

Find the length of the chord, which subtends an angle of 80° at the center of a circle of radius 5cm.

Solution

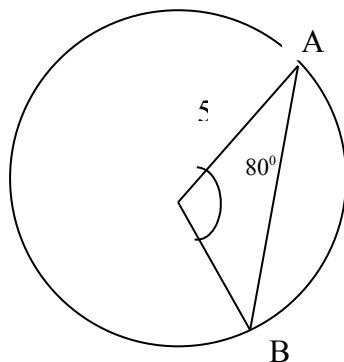

Fig. 4.8.4

Let the chord be AB as in fig 4.8.4

Length of chord $AB = 2r \sin \theta/2$

Here $r = 5\text{cm}$, $\theta = 80^\circ$

Therefore, $\theta/2 = 80/2 = 40^\circ$

Substituting in the above formula

$$\begin{aligned}\text{Length of chord AB} &= 2 \times 5 \sin 40^\circ \\ &= 10 \sin 40^\circ \\ &= 10 \times 0.64 = 6.4\text{cm}\end{aligned}$$

Having determined the length of the chord, we can proceed to find the perimeter of a segment, by adopting the following procedures.

The perimeter of a segment = length of arc of the circle from which the segment is formed plus the length of the chord.

That is, perimeter = length of arc + length of chord

$$\begin{aligned}&= 1 + 2r \sin \theta/2 \\ &= \frac{2\pi r \theta}{360} + 2r \sin \theta/2 \\ &= \theta/360 \times 2\pi r + 2r \sin \theta/2 \text{ units} \\ \theta/180 \times \pi r + 2r \sin \theta/2 \text{ units} &= \frac{\theta}{180} \pi r + r \sin \theta\end{aligned}$$

Example 4.8.4 (b)

If AB is a chord of a circle with center O and radius 6cm. $\angle AOB = 120^\circ$. Calculate the perimeter of the minor segment (Take $\pi = 22/7$).

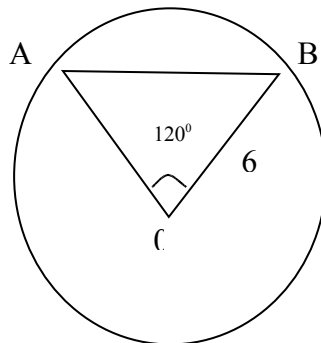

$$\text{Chord AB} = 2r \sin \theta/2$$

$$r = 6\text{cm}, \theta = 120^\circ$$

$$\text{Therefore } \theta/2 = 120^\circ/2 = 60^\circ$$

$$\text{So, chord AB} = 2r \sin 60^\circ$$

$$= (2 \times 6) \sin 60^\circ$$

$$= 12 \sin 60^\circ$$

$$12 \times \frac{\sqrt{3}}{2} = 6\sqrt{3} = 6 \times 1.7320 = 10.39\text{cm}$$

$$\text{Length of arc AB} = 120/360 \times 2 \times 22/7 \times 6$$

$$= 1/3 \times 12 \times 22/7 = 88/7$$

$$= 12.57$$

Therefore, the perimeter of the minor segment =

= length of arc + chord

$$= 12.57 + 10.39$$

= 22.96.cm.

SELF ASSESSMENT EXERCISE 7

XY is a chord of a circle with center O and radius 5cm $\angle XOY = 240^\circ$. Calculate the perimeter of the major segment. (Take $\pi = 22/7$).

4.0 CONCLUSION

Here, in this unit, you have learnt about the perimeter of some plane shapes and figures. In particular you have been exposed to the procedures for the determination of the distance round these plane shapes (perimeter) such as, parallelogram, triangle, rectangle, polygon and circle. You equally, learnt about the calculation of length of arc and a chord of circular objects.

5.0 SUMMARY

In this unit you have been exposed to the following:

- That perimeter refers to the distance round an object or a figure.
- That, for a plane figure the perimeter is the distance round that figure
- The perimeter of a parallelogram is found by the expression $2(L+B)$. it is same for a rectangle.
- For a triangle, the perimeter is determined say for $\triangle ABC$ by $a + b + c$
- For a regular polygon, the perimeter is calculated by multiplying the known side by the number of sides.
- For an irregular polygon, the perimeter is given by the sum of the lengths of all the sides.
- Interior angles of a polygon = $(n - 2) \times 180^\circ$
- An interior angle of a regular polygon is equal to $\frac{n - 2}{n} \times 180^\circ$ or $\frac{(2n - 4)}{n}$ right angle
- The perimeter of sector AOB of a circle is $(2r + l)$
- The length of an arc of a circle is $\frac{\theta}{360} \times 2\pi r$
- The length of a chord is calculate by the expression, $2r \sin \frac{\theta}{2}$ units
- The perimeter of a segment of a circle is determined by $\frac{2\pi r \theta}{360} + 2r \sin \frac{\theta}{2}$

6.0 TUTOR-MARKED ASSIGNMENT

1.
 - a. What do you mean by (i) perimeter of a plane figure (ii) circumference of a circle (iii) segment of a circle (iv) arc of a circle
 - b. Draw diagrams to show the phenomena explained in 1a (i) – (iv) above.
2. A rectangle of 16cm long is equal in area to a square which has a perimeter of 32cm find the width of the rectangle.
3. AB is a chord of a circle with center O and radius 4cm. $\angle AOB = 240^\circ$ calculate the perimeter of the major segment (take $\pi = 22/7$).

7.0 REFERENCES/FURTHER READINGS

- David Osuagun, M. N. (2004). *New School Mathematics for Senior Secondary Schools*. Lagos: Africana First Publishers 306 – 322.
- Olayanju, S. O. & Olosunde, G. R. (2001). *Primary Mathematics Curriculum and Shapes Measurement*. Lagos: SIBIS Ventures, 30 – 49.

UNIT 2 AREAS

CONTENTS

- 1.0 Introduction
- 2.0 Objectives
- 3.0 Main Content
 - 3.1 Meaning and Unit of Area
 - 3.1.1 Units of Area
 - 3.2 Area of Plane Shapes
 - 3.3 Area of Rectangular Shapes
 - 3.4 Area of a Parallelogram
 - 3.5 Area of Trapezium
 - 3.6 Area of Circle
 - 3.6.1 Area of a Sector
- 4.0 Conclusion
- 5.0 Summary
- 6.0 Tutor-Marked Assignment
- 7.0 References/Further Readings

1.0 INTRODUCTION

In the preceding unit you were treated to what perimeters of objects and shapes are, step or procedures to be followed in determining the perimeter of any given shape or figure. In order to drive home the point, such shapes as rectangles, circles etc were considered. In this unit, we shall deal with areas of solid shapes and how we can determine the areas of such shapes or figures. Specifically, reference shall be made to rectangular shapes, topics parallelogram and circular shapes.

2.0 OBJECTIVES

Students should be able to do the following by the end of this unit:

- define the term area of an object
- state the unit for calculating the area of an object
- find the area of triangular shapes
- calculate the area of a trapezium
- find the area of a circular object.

3.0 MAIN CONTENT

3.1 Meaning and Units of Area

The term 'area' is usually conceived as the product of length and breadth of any given shape. In fact, the area of an object is the space occupied by that object. For instance, in figure 5.1 below the area of the rectangle PQRS is the shaded portion as shown.

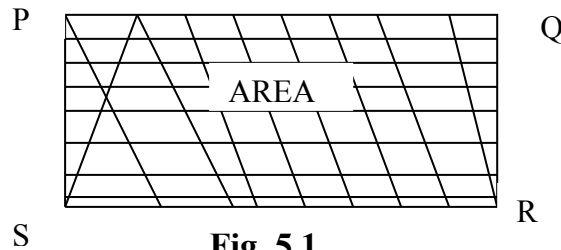

Fig. 5.1

Hence, the area of an object can be taken to be an enclosed region bounded by either straight lines and or curves or arcs. In the case of three-dimensional solids and objects we often talk of total surface area and / or cross-sectional areas of these objects. Such objects include, pyramid, cuboids, cylinders and cones, because the surfaces of each of the objects are made up of plane shapes such as rectangles, squares or triangles. So, finding the area of a prism for example, means finding the area of the triangles and rectangles, which combine to form the prism.

3.1.1 Units of Area

Area of an object is measured in square units. For instance, area can be measured in square millimeters, square centimeters, square meters and square kilometers. Below is an illustration of units for measuring area.

100 square millimeters (mm^2) = 1 square centimeter (cm^2)

100 square centimeters = 1 square decimeter (dm^2).

xvi. square decimeters = 1 square meter (m^2)

100 acres = 1 hectare.

100 hectares = 1 square kilometers (km^2).

$1 \text{ km}^2 = 1000 \times 1000 \text{ m}^2 = 1,000,000 \text{ m}^2$.

$1 \text{ m}^2 = 100 \times 100 \text{ cm}^2 = 10,000 \text{ cm}^2$.

$1 \text{ m}^2 = 1000 \times 1000 \text{ mm}^2 = 1,000,000 \text{ mm}^2$.

3.2 Area of Plane Shapes

Triangles (Revision)

You would recall that in Unit one this Module, we dealt extensively with calculation of areas of triangles. Let's quickly remind ourselves of the different methods of determining the area of triangles as this has the potential of assisting in calculating the areas of some other shapes as discussed under section 5.3.

(a) When the height of the triangle is given

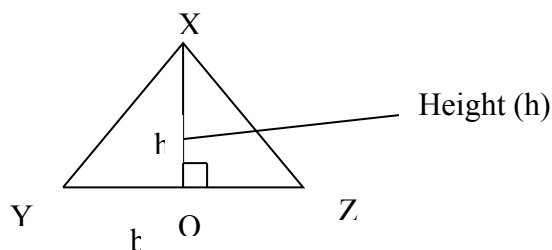

Fig. 5.2

$$\begin{aligned} \text{Area of } \triangle XYZ &= \frac{1}{2} \times \text{base} \times \text{height} \\ &= \frac{1}{2} \times YZ \times XO \\ &= \frac{1}{2} \times bh \text{ sq units.} \end{aligned}$$

(b) when the sides and an inclined angle are given,

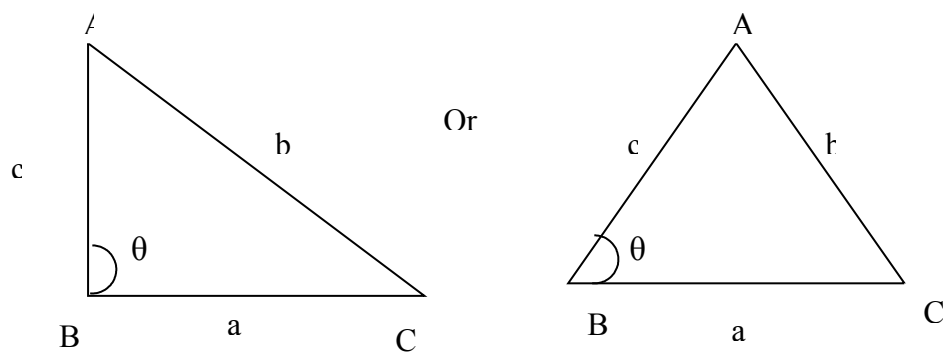

Fig. 5.3

$$\begin{aligned} \text{Area of } \triangle ABC &= \frac{1}{2} \times AB \times BC \sin \theta \\ &= \frac{1}{2} \times c \times a \sin \theta \\ &= \frac{1}{2} \times ac \sin \theta \text{ sq units.} \end{aligned}$$

(c) When the three sides are given, the Hero's formula is used

$$\sqrt{s(s-a)(s-b)(s-c)}$$

$$\sqrt{s(s-a)(s-b)(s-c)} \text{ Square units}$$

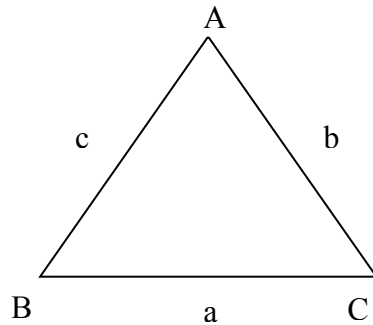

$$\text{The Area of } \triangle ABC = \sqrt{s(s-a)(s-b)(s-c)} \text{ Square units}$$

Where $s = \frac{a+b+c}{2}$ i.e. half the perimeter of the triangle and a, b, c are the Given sides of the triangle.

Example 5.1

Find the area of the Δ below

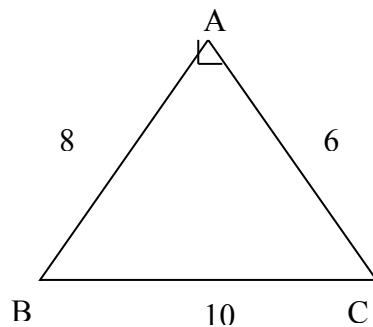

Solution

Because the three sides are given the Hero's formula is applied.

$$\text{Area} = \sqrt{s(s-a)(s-b)(s-c)} \text{ Square units}$$

$$s = \frac{10+6+8}{2} = 12\text{cm.}$$

$$a = 10\text{cm, } b = 6\text{cm, } c = 8\text{cm}$$

then, $s - a = 12 - 10 = 2$, $s - b = 12 - 6 = 6$ and $s - c = 12 - 8 = 4$

$$\begin{aligned} \text{area of } \Delta ABC &= \frac{\sqrt{12 \times 2 \times 6 \times 4}}{\sqrt{12^2 \times 2^2}} \text{ Square unit (cm)} \\ &= 12 \times 2 = 24 \text{ square cm} \end{aligned}$$

Alternatively,

The triangle with sides, 6, 8, and 10 is a right angled triangle

Here $\angle A = 90^\circ$,

Then area of ABC = $\frac{1}{2}$ x base x height

$$= \frac{1}{2} \times 8 \times 6 = 24\text{cm}^2$$

SELF ASSESSMENT EXERCISE 1

- i. Find the area of a right angled triangle with base 10cm and height 4cm.
- ii. Find the area of a triangle with sides $a = 12\text{cm}$ $b = 8\text{cm}$ and $c = 10\text{cm}$.

3.3 Area of Rectangles Shapes

Area of any rectangular shape is usually deduced by multiplying the length and the breadth. As stated in section 3.4, the area of a rectangle is measured in square unit. At times, area of rectangle can be expressed as the product of length and the width in square unit figure 5.4 illustrates this.

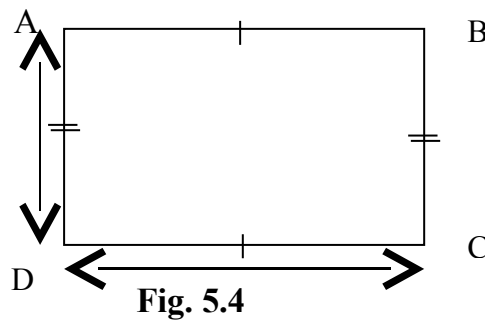

In figure 5.4, area of rectangle ABCD = $AB \times BC$ or $AD \times CD$. This is because $\overline{AB} = \overline{CD}$ = length and $\overline{AD} = \overline{BC}$ width / breadth of the rectangle.

Example 5.2

A rectangular room is 30cm by 20cm, find the area in square metres.

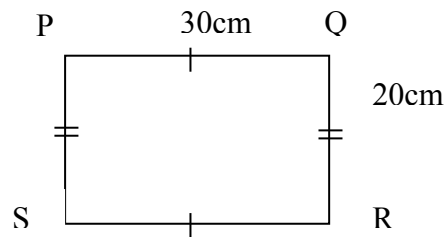
Solution

Length of the room = 30cm

Breadth of the room = 20cm

$$\begin{aligned} \text{Area of rectangle PQRS} &= \text{Length} \times \text{breadth} \\ &= 30 \times 20 \\ &= 600 \text{ square cm i.e. } 600\text{cm}^2. \end{aligned}$$

But $100\text{cm}^2 = 1\text{m}^2$

$$\begin{aligned} \text{Therefore, } 600\text{cm}^2 &= \frac{600}{100} \\ &= 6\text{m}^2. \end{aligned}$$

Example 5.3

The area of a rectangular field is 480m^2 . Find the length in metres if the breadth of the field is $2,400\text{cm}^2$.

Solution

Area of the field = 480m^2

Breadth of the field = $2,400\text{cm} = 24$

$$\begin{aligned} \text{Length of the field} &= \frac{\text{Area}}{\text{Breadth}} = \frac{480\text{m}^2}{24\text{m}} \\ &= 20\text{m} \end{aligned}$$

SELF ASSESSMENT EXERCISE 2

Find the area of a rectangle ABCD whose length is 24dm and the width of 15dm. Give your answer in metres.

3.4 Area of a Parallelogram

In calculating the area a parallelogram let us consider the parallelogram ABCD below with sides x and y and the inclined angle θ and height h . (see figure 5.5), then the area of the parallelogram is equal to:

- (i) base \times height = $AB \times h$
- (ii) $AB \times BC \sin \theta = xy \sin \theta$.

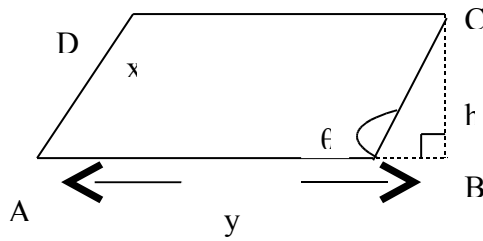

Fig. 5.5

Let us examine some examples to drive home our point.

Example 5.4

Find the area of parallelogram ABCD (See fig. 5.6)

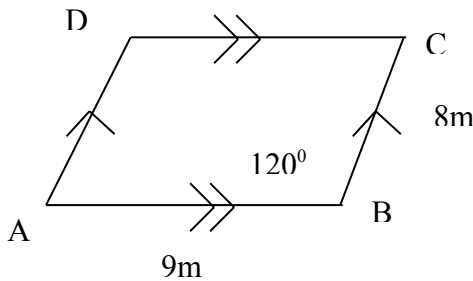

Fig. 5.6

Solution

Area of parallelogram ABCD = $AB \times BC \sin Q$ sq units

Here $AB = 9\text{cm}$, $BC = 8\text{cm}$ and $\sin Q = \sin 120^\circ$

$$\begin{aligned} \text{Therefore, area of parallelogram ABCD} &= 8 \times 9 \sin 120^\circ \\ &= 8 \times 9 \sin 60^\circ \\ &= (\sin 180 - 120)^\circ = \sin 60^\circ. \\ &= 72 \times \frac{\sqrt{3}}{2} \\ &= 36 \sqrt{3} \text{ cm}^2 \end{aligned}$$

Example 5.5

Find the area of the parallelogram show in the figure below.

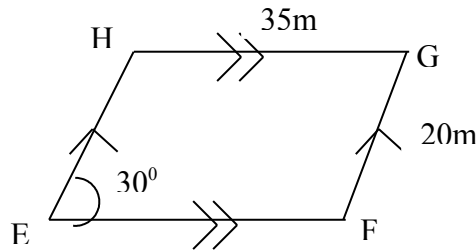

Solution

$$\begin{aligned}
 \text{Area} &= EF \times EH \times \sin 30^\circ \\
 &= 35 \times 20 \times \sin 30^\circ \\
 &= 700 \times 0.5 \\
 &= 350\text{m}^2
 \end{aligned}$$

SELF ASSESSMENT EXERCISE 3

Find the area of a parallelogram with length 20cm, if the corresponding height is 12cm.

3.5 Area of a Trapezium

You would recall that a quadrilateral in which one pair of opposite sides are parallel but not equal is called a trapezium. In this unit other properties of trapezium were discussed. In this section we shall deal with the determination of area of a trapezium. In order to gain a good understanding of how this is done the following steps are due for consideration. (i) Let us consider a figure 15.6, a trapezium; in which AD is parallel to BC, and where AD = a, BC = b and BD is a diagonal.

- (ii) Draw the diagonal BD to divide the figure into two equal triangles. ABD and BCD.
- (iii) Construct the altitudes of these triangles (h) i.e. BE and DF.

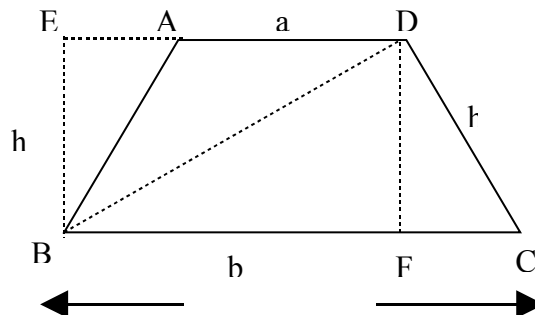

Fig. 5.6

- (iv) Let $EB = DF = h$; the distance between the two parallel sides AD and BC.

- (v) The area of the figure ABCD = Area of $\triangle ABD$ + Area of $\triangle BCD$
 $= \frac{1}{2} a \times h + \frac{1}{2} b \times h$
 $= \frac{h}{2} (a + b) = \frac{1}{2} (a + b) h$. sq units.
- (vi) This implies that, the area of a trapezium is the average of the sum of parallel sides multiplied by the perpendicular distance between them (i.e. height).

That is, Area of trapezium ABCD = $\frac{1}{2}$ sum of parallel sides x perpendicular height.

Let's now look at some examples in order to drive home the point.

Example 5.6

1. In a trapezium ABCD, the sides AD and BC are parallel, BC = 40cm, AD = 30cm and the distance between BC and AD is 20cm. Calculate the area of the trapezium.

Solution

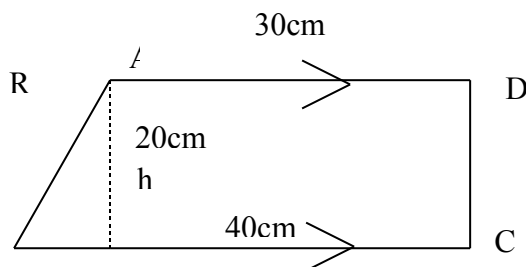

$$\begin{aligned}
 \text{Area of trapezium ABCD} &= \frac{1}{2} AD + BC \times h \\
 &= \frac{1}{2} (40 + 30) \times 20 \\
 &= \frac{1}{2} \times 70 \times 20 \\
 &= 35 \times 20 \text{ square cm.} \\
 &= 700\text{cm}^2.
 \end{aligned}$$

Example 5.7

The area of a trapezium is 128cm^2 and the height is 16cm. If one of the parallel sides is 12cm. Find the length of the other parallel side.

Solution

$$\begin{aligned}
 \text{Area of the trapezium} &= 128\text{cm}^2 \\
 \text{Height of the trapezium} &= 16\text{cm.} \\
 \text{One of the parallel sides} &= 12\text{cm} \\
 \text{Let the other side be } x. & \\
 \text{Area of a trapezium} &= \frac{1}{2} (12 + x) \times 16 = 128\text{cm}^2 \\
 \text{Thus, } (12 + x) \times 8 &= 128\text{cm}^2
 \end{aligned}$$

$$\begin{aligned}
 (12 + x) \times 8 &= 128\text{cm}^2 \\
 96 + 8x &= 128\text{cm}^2 \\
 8x &= 128 - 96 \\
 8x &= 32 \\
 x &= 32/8 = 4\text{cm}
 \end{aligned}$$

Therefore, the length of the other side is 4cm.

SELF ASSESSMENT EXERCISE 4

In a trapezium ABCD, the sides AD and BC are parallel BC = 40cm, AD = 30cm and the distance between BC and AD is 20cm. Calculate the area of the trapezium.

3.6 Area of a Circle

Recall that in Unit three of this Module properties of plane shapes of which circle is one was extensively discussed. Here in this section, we shall look at the procedure to follow in the determination of the area of a circle. Ordinarily, the area of a circle is calculated by using the formula, πr^2 where r stands for the radius of the circle and π is equal to $22/7$ or 3.142. Let us consider some examples to enable us see clearly how this formula is applied. Examples 5.8.1 and 5.8.2 serve to illustrate this.

Example 5.8.1

Find the area of the circle of radius 7cm. (take $\pi = 22/7$)

Solution

$$\begin{aligned}
 \text{Given that, radius} &= 7\text{cm, } \pi = 22/7 \\
 \text{Area of a circle} &= \pi r^2 \\
 &= 22/7 \times 7 \times 7 \\
 &= 22 \times 7 \\
 &= \underline{154\text{cm}^2}
 \end{aligned}$$

Example 5.8.2

If the circumference of a circle is 176cm. Find its area.

Solution

Let's use the given circumference to find the radius first.

Circumference of the circle = 176cm.

$$2 \pi r = 176\text{cm.}$$

$$r = \frac{176 \times 7}{1 \times 22 \times 2} \text{ cm}$$

$$r = 28\text{cm}$$

Area of the circle = πr^2

$$= \frac{22}{7} \times 28 \times 28$$

$$= 24.64\text{cm}^2$$

SELF ASSESSMENT EXERCISE 6

The area of a circle is 616cm^2 . Find its circumference

3.6.1 Area of a Sector

Remember that in Unit thereof this Module on the properties of circle, a sector was defined as a plane figure bounded by two radii and an arc. Based on this background knowledge about what a sector of a circle means, we shall now look at how the area of a sector of a circle can be achieved. Generally, the area of a sector whose radii subtend an angle of θ at the center is given by $\frac{\theta}{360} \pi r^2$. Example 5.8.1 serves to illustrate how the area of a sector is determined.

Example 5.9.1

Find the area of a sector of a circle radius 14cm, which subtends an angle of 60° at the center.

Solution

$$\begin{aligned} \text{Area of a sector} &= \frac{\theta}{360} \times \pi r^2 = \frac{60}{360} \times \frac{22}{7} \times 14 \times 14 \\ &= \frac{22 \times 14}{3} = \frac{308}{3} = 102.7\text{cm}^2 \end{aligned}$$

SELF ASSESSMENT EXERCISE 7

The area of a circle with center O is 36cm^2 . What is the area of sector AOB if $\angle AOB$ is 45° ?

4.0 CONCLUSION

In this unit, you have been exposed to the procedures for determining the area of some plane shapes/figures. In an attempt to do we, the discussed the meaning of area and the unit of area was given in square units Specimen calculations of the areas of rectangle, parallelogram, trapezium, circle and a sector were done to drive home the points.

5.0 SUMMARY

In this unit you have learnt the following:

- The term area is the product of length and breadth of any given shape.
- Specifically, area of an object is the space occupied by that object.
- For three-dimensional solids and objects, we talk of total surface area
- Area is usually measured in square units
- Area of rectangle is determine by the product of length and width (breadth)
- Area of trapezicium is given by $\frac{1}{2} (a + b) \times \text{height}$
- Area of parallelogram = base x height sin θ
- Area of circle is given by πr^2
- Area of a sector is given by $\frac{\theta}{360} \pi r^2$

360

6.0 TUTOR-MARKED ASSIGNMENT

1. Define the area of an object.
2. Find the area of a circle of radius 5cm (take $\pi = 22/7$)
3. Find the area of a trapezium whose 2 parallel sides are 5.6 and 7cm and height of 6cm.

7.0 REFERENCES/FURTHER READINGS

David Osuagwu; M. N. Anemelu, C & Onyeozili, 1. (2004). *New School Mathematics for Senior Secondary Schools*. Lagos: African First Publishers.

Olayanju, S.O & Olosunde, G.R (2001). *Shapes' Measurement for Schools and Colleges*. Lagos: Sibis Ventures.

UNIT 3 SURFACE AREAS OF SOLID OBJECT (THREE DIMENSIONAL OBJECTS)

CONTENTS

- 1.0 Introduction
- 2.0 Objectives
- 3.0 Main Content
 - 3.1 Prism
 - 3.1.1 Surface Area of a Prism
 - 3.2 The Pyramid
 - 3.2.1 Total Surface Area of a Pyramid
 - 3.3 The Cylinder
 - 3.3.1 Total Surface Area of Cylinders
 - 3.4 The Cone
 - 3.4.1 Surface Area of a Cone
 - 3.5 Sphere
 - 3.5.1 Surface Area of a Sphere
- 4.0 Conclusion
- 5.0 Summary
- 6.0 Tutor-Marked Assignment
- 7.0 References/Further Readings

1.0 INTRODUCTION

In Module 1 Unit seven, we dwelt extensively on types and properties of a number of solid objects (or what we called three-dimensional objects). Among these objects are prism, pyramid, cylinder, cone and sphere. Also in the preceding unit, we discussed largely on how to determine the area of some plane shapes/objects. Our knowledge about the areas of these plane shapes would go a long way in assisting us to gain good understanding of the surface area of these 3-dimensional objects; which forms the fulcrum of this present unit.

2.0 OBJECTIVES

At the end of this unit, students should be able to:

- define what a prism is
- mention different kinds of prism
- determine the surface area of a prism
- find the total surface areas of solids such a prism, pyramid etc
- determine the curved and total surface area of a cylinder
- calculate the total surface area of a sphere.

3.0 MAIN CONTENT

3.1 Prism

(a) A prism is a solid with a uniform cross-section of a shape of a triangle or a trapezium or another polygon (see figure 6.1)

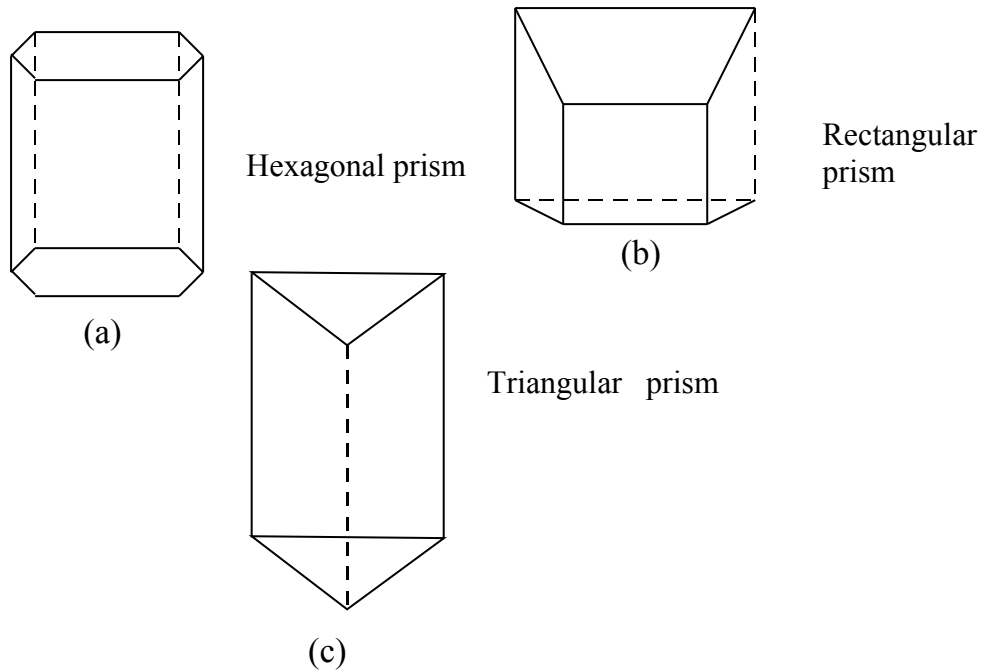

Fig. 6.1

b) Types of Prism

Prisms exist in their various forms. The name associated with each indicates its uniform cross-section. For example triangular prism-a prism whose uniform cross-section is in the shape of triangle (figure 6.1(c)), rectangular prism or cuboid is prism whose uniform cross-section is in the shape of rectangle (figure 6.1(b)) figures 6.1 (a) is an hexagonal. Furthermore, a prism is triangular or quadrangular etc depending on the shape of its cross section-triangle or quadrilateral.

3.1.2 Surface Area of a Prism

Due to the fact that, a prism is a solid we often talk of total surface area and not just area of a prism. The reason is that a prism and other solids are made up of the same or different plane shapes. For example triangular prism, the end shapes are triangle while the side faces are rectangles. The figure 6.2 (a) and (b) illustrate the prism and net prism.

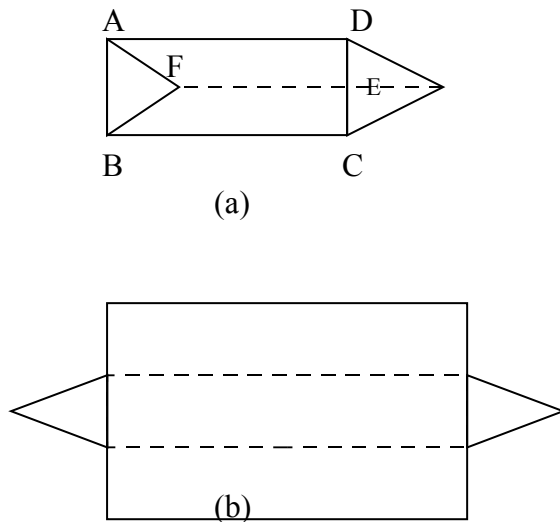

Fig 6.2

The total surface area of a prism = Areas of ABCD + AFED + BCEF + Areas of (Δ s (ABF + DCE))

Let us illustrate this with an example.

Example 6.1

Find the total surface area of the prism shown in figure 6.3

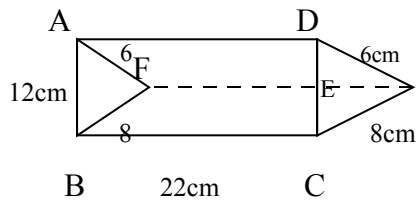

Solution

We need to first find the areas of the individual faces and then sum them up.

$$\text{Area of ABCD} = 22 \times 12 \text{ cm}^2 = 264\text{cm}^2$$

$$\text{Area of AFED} = 6 \times 22 \text{ cm}^2 = 132 \text{ cm}^2$$

$$\text{Area of BCEF} = 8 \times 22 \text{ cm}^2 = 176 \text{ cm}^2$$

$$\text{Area of } \Delta\text{ABF} = \frac{1}{2} \times 8 \times 6 = 24\text{cm}^2$$

$$\text{Area of } \Delta\text{ABF} = \text{Area of } \Delta\text{DCE} = \frac{1}{2} \times 8 \times 6 = 24\text{cm}^2$$

Therefore, the total surface area the triangular prism is $(264 + 132 + 176 + 24 + 24) \text{ cm}^2 = 620\text{cm}^2$

Alternatively,

The length 22cm is common to the three rectangles we have their areas = $22(6+8+12) = 572\text{cm}^2$ as the total area of the three rectangular faces. In finding the area of the triangular faces we can use the Hero's formula

$$\sqrt{s(s-a)(s-b)(s-c)}$$

Where $s = \frac{a + b + c}{2}$ and a, b, c, are the lengths of the sides of the triangle

Thus, $s = \frac{12 + 6 + 8}{2} = \frac{26}{2} = 13\text{cm}$, $s - a = 13 - 6 = 7$, $s - b = 13 - 8 = 5$, $s - c = 13 - 12 = 1$

Area of $\triangle ABF = \sqrt{13 \times 7 \times 5 \times 1} = \sqrt{455} = 21.3\text{cm}^2$
 Area of $\triangle DCE = 21.3\text{cm}^2$

The total surface area of the prism is $572\text{cm}^2 + 21.3 + 21.3 = 615$ which is approximately same as the first answer if it is rounded up.

SELF ASSESSMENT EXERCISE 1

Find the surface area of a triangular prism 10.8 am long and having a triangular face of dimensions 8.8cm by 5.7cm by 6.8cm.

With other forms of prisms, the same steps are followed i.e. by finding the area of all the faces and the two end faces, then sum them up to obtain the total surface area. Students should note how to:

- i) find the areas of the uniform cross-section at both ends
- ii) find the area of the rectangular faces by multiplying the length of the prism with the perimeter of the cross-section and
- iii) sum up (i) and (ii)

Example 6.2

Find the total surface area of the solid shown in the figure 6.3 below:

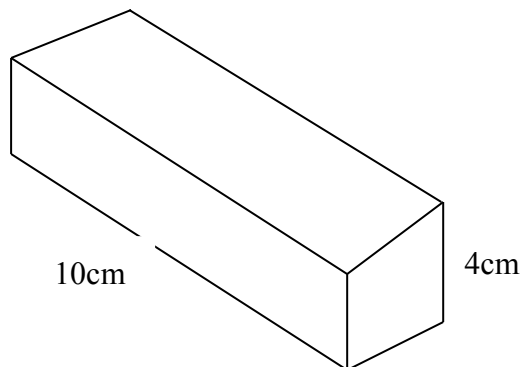

$$\begin{aligned} \text{Area of } A &= 5 \times 4\text{cm}^2 = 20\text{cm}^2 \\ \text{Area of B} &= 10 \times 5\text{cm}^2 = 50\text{cm}^2 \\ \text{Area of C} &= 10 \times 4\text{cm}^2 = 40\text{cm}^2 \\ \text{Area of D} &= 10 \times 5\text{cm}^2 = 50\text{cm}^2 \\ \text{Area of E} &= 10 \times 4\text{cm}^2 = 40\text{cm}^2 \\ \text{Area of F} &= 5 \times 4\text{cm}^2 = 20\text{cm}^2 \\ \text{Therefore, total surface area} &= 220\text{cm}^2 \end{aligned}$$

3.2 The Pyramid

A pyramid is a solid whose base is a polygon and has a common joint point (or vertex). A pyramid could be triangular, quadrangular etc if its base is triangular or quadrangle (quadrilateral) see figure 6.4

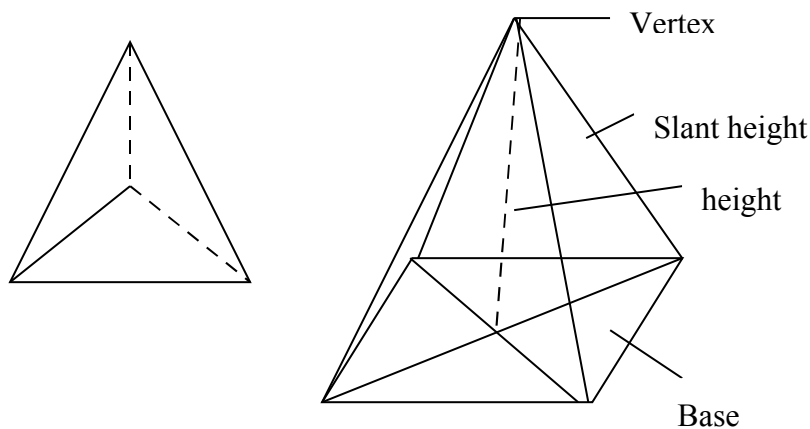

Fig. 6.4

A pyramid is regular if its base is a regular polygon and the perpendicular height falls in the center of the base.

3.2.1 Total Surface Area of a Pyramid

The total surface area of a pyramid is determined by summing up areas of the common shapes that make up the pyramid. The following example, illustrates this:

Example 6.4.1

Find the total surface area of a right pyramid with rectangular base 6cm by 10cm, a height of 8.5cm and a slant edge of 10.20cm

Solution

The total surface area is the sum of the surface area of the five faces namely:

- (i) the rectangular face ABCD
- (ii) the triangular faces VAB, VDC, VBC and VAD. (each face is a right-angled triangle, AB = DC and AD = BC)

If AB = 10cm, then DC = AB = 10cm

If AD = 6cm, then BC = AD = 6cm

Hence area of rectangle base ABCD = 10 x 6 = 60cm²

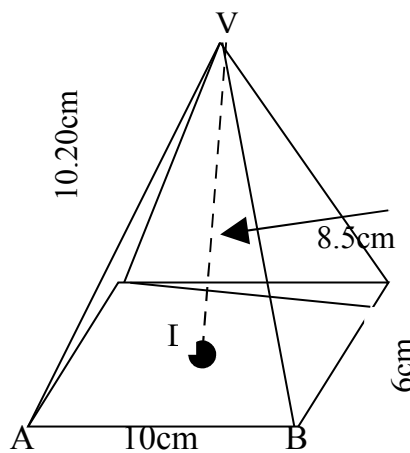

Fig. 6.5

Area of ΔVAB = area of ΔVDC and area of ΔVBC = area of ΔVAD

In fig 6.6 Area of $\Delta VAB = \frac{1}{2} AB \times VP$

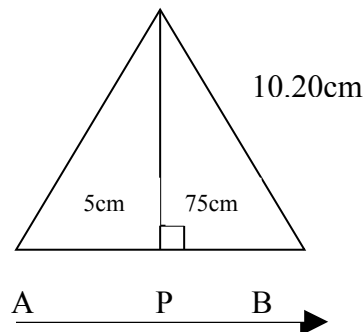

Fig. 6.6

But $(VP)^2 = VB^2 - (PB)^2$ – (Pythagoras theorem)

$$(10.20)^2 - 5^2 = 104.04 - 25$$

$$79.04$$

$$VP = \sqrt{79.04} = 8.89\text{cm}$$

Therefore, Area of $\triangle VAB = \frac{1}{2} AB \times VP$
 $= \frac{1}{2} \times 10 \times 8.89$
 $= 5 \times 8.89$
 $= 44.45\text{cm}^2 = \text{Area of } \triangle VDC$

In figure 6.7 Area of $\triangle VBC = \frac{1}{2} BC \times VF$

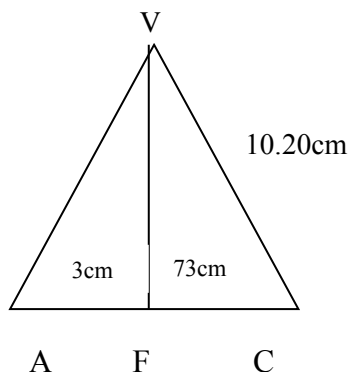

Fig. 6.7

But $VF^2 = (VC)^2 - (FC)^2$
 $= (10.2)^2 - 3^2 = 104.04 - 9 = 95.04\text{cm}^2$
 $VF = \sqrt{95.04} = 9.74\text{cm}$

Therefore, Area of $\triangle VBC = \frac{1}{2} BC \times VF$
 $= \frac{1}{2} \times 6 \times 9.74$
 $= 3 \times 9.74 = 29.22\text{cm}^2$
 $= \text{Area of } \triangle VAD$

Area of rectangular base $ABCD = 10 \times 6 = 60\text{cm}^2$

Therefore, the total surface area of the pyramid
 $= \{(44.45 + 44.45) + (29.22 + 29.22) + 60\}$
 $= (88.90 + 58.44 + 60)$
 $= 207.34\text{cm}^2$

SELF ASSESSMENT EXERCISE 2

In figure 6.8, find

- i. the length of a slant edge
- ii. the surface area of a right pyramid with a rectangular base measuring 10cm by 12cm. The height of the pyramid is 16cm

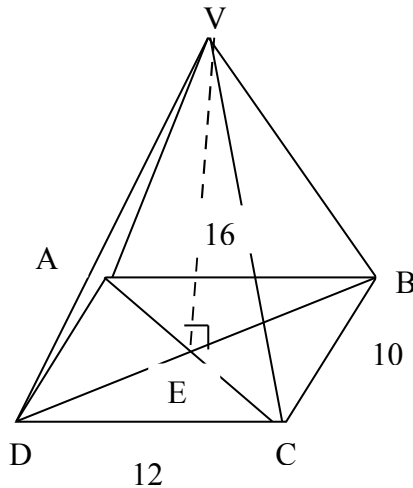

Fig. 6.8

3.3 The Cylinder

A cylinder is a solid of uniform circular cross-section. Several examples of objects that are cylindrical in shape abound around us. Examples of such objects include unsharpened pencil like HB or 2B pencils; tin of milk or tomatoes, garden rollers converting, drum to mention a few.

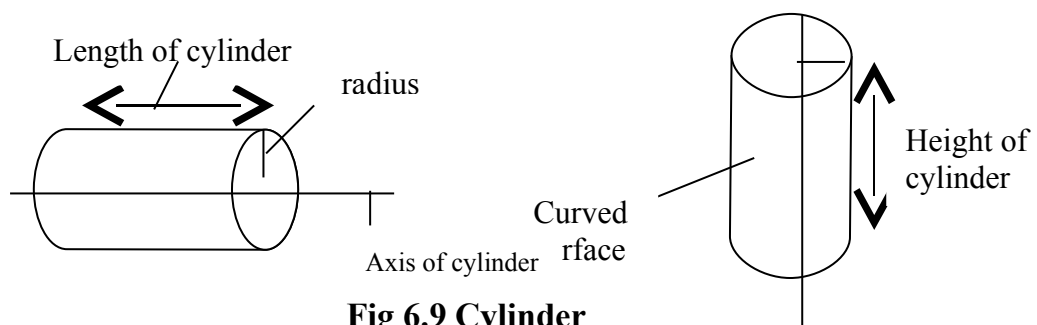

Fig 6.9 Cylinder

In figure 6.9 the radius of the cylinder is the radius of the circular cross-section and the length or height of the cylinder is the distance between the two circular end faces of the cylinder.

3.3.1 Total Surface Area of Cylinders

There are two kinds of cylinders to be discussed in this section namely:

- i) a closed cylinder and
- ii) an open cylinder

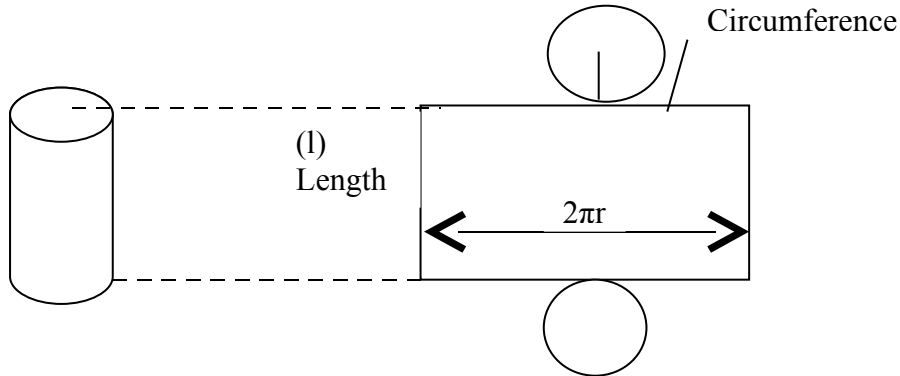

FFig. 6.10: Closed Cylinder

a) Total surface Area of a Closed Cylinder

The total surface area of a closed cylinder is made up of the sum of the areas of (i) the curved surface and (ii) the two circular end faces. (see fig 6.10(a)).

The curved surface when opened out is a rectangle (see fig 6.10 (b)). This rectangle has length, which is equal to the circumference of the end face.

Therefore, Area of the curved surface of cylinder.

= area of rectangle of dimensions length (l) and width (circumference of base) $2\pi r = 2\pi r l$ sq unit

Area of the two circular end faces = twice the area of one circular face = $2\pi r^2$ sq units

Hence the total surface area of the closed cylinder = $2\pi l + 2\pi r^2$ sq units.

Simplifying by factorization, have.

$$2\pi r l + 2\pi r^2 = 2\pi r (l+r) \text{ sq units.}$$

Where l is the length of cylinder and r is the radius of the circular end face.

Example 6.3

- a) Calculate the total surface area of a closed cylinder whose radius is 3.5cm and height is 7cm

Solution

$$\begin{aligned} \text{Total surface area of the cylinder} &= 2\pi r (r + h) \\ &= 2 \times \frac{22}{7} \times 3.5 (3.5 + 7) \\ &= 22 (3.5 + 7) \\ &= 22 (10.5) \\ &= 231\text{cm}^2 \end{aligned}$$

- b) If the total surface area of a solid cylinder of base radius 7cm is 440cm^2 calculate the height of the cylinder.

Solution

$$\text{Surface area} = 2\pi r (r + h), \text{ i.e. } 440 = 2 \times \frac{22}{7} \times 7 (7 + h) = 44 (7 + h)$$

$$\frac{440}{44} = 7 + h$$

$$10 = 7 + h$$

$$h = 10 - 7 = 3\text{cm}$$

Hence, the height of the cylinder is 3cm

It should be noted that, a cylinder may be closed only at one end. In such a situation, the total surface area is given by

$$\begin{aligned} \text{Area of curved surface} + \text{area of one circular end face} \\ &= 2\pi r l + \pi r^2 \text{ sq units} \\ &= 2\pi r (2l + r) \text{ sq units.} \end{aligned}$$

(b) Total Surface Area of an Open Cylinder

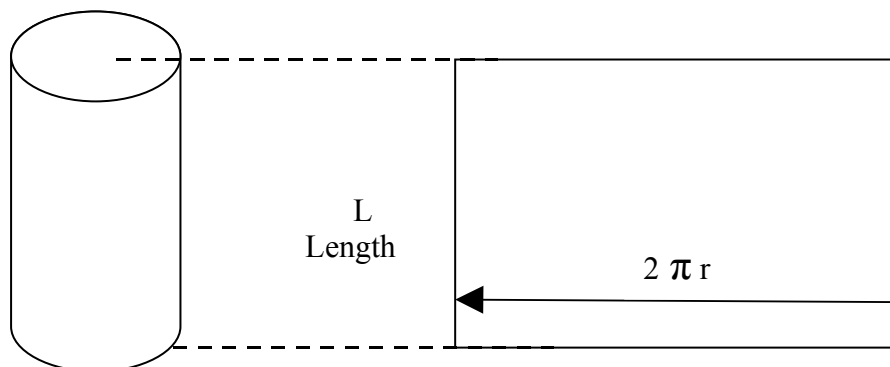

(a) Open Cylinder

(b) Net of Open Cylinder

Fig. 6.11

The total surface area of an open cylinder is the area of the curved surface which is the area of the rectangle shown in the net (fig. 6.11(b)).

Sometimes, it is possible to have a thick hollow cylinder as shown in fig.

(c) The Total Surface Area Is the Sum Of

- (i) the area of the external curved surface
- (ii) the area of the internal curved surface
- (iii) the area of the end annular faces shaded in fig 6.12 (b) (showing cross section).

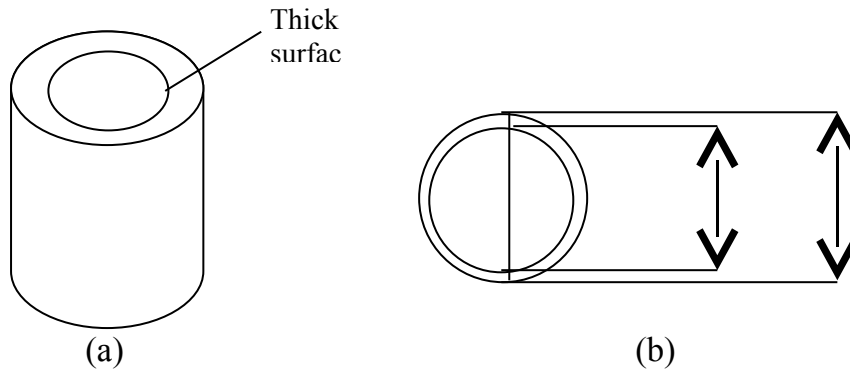

Fig. 6.12

Example 6.4

Find the total surface area of a culvert ring 6.0cm long external diameter 36cm and internal diameter 20cm (take $\pi = 3.14$)/

Solution

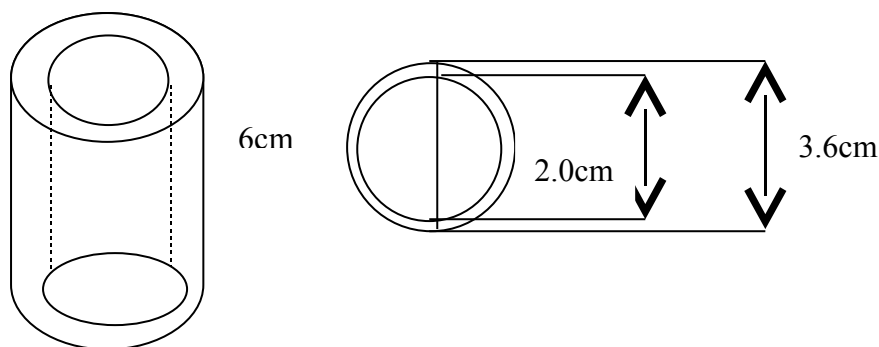

Fig. 6.13

The total surface area is the sum of

- (i) the area of the external curved surface length 6.0cm
- (ii) the area of the internal curved length 20cm
- (iii) the area of the two end surfaces showing the radii as shaded in 6.13 showing the cross-section about

r_1 , = the radius of the external circle = $3.6/2 = 1.8\text{cm}$

r_2 = the radius of the internal circle = $2.0/2 = 1.0\text{cm}$

$\pi = 3.142$ and $l = 6.0\text{cm}$

Therefore, area of external curved surface = $2\pi r_1 l$
 $= 2 \times 3.142 \times 1.8 \times 6\text{cm}^2$
 $= 6.28 \times 1.8 \times 6$
 $= 67.82\text{cm}^2$

Area of internal curved surface = $2\pi r_2 l$
 $= 2 \times 3.14 \times 1.0 \times 6\text{cm}^2$
 $= 6.28 \times 1 \times 6$
 $= 37.68 \text{ cm}^2$

Area of one annulus = area of external circle – area of internal circle
 $= \pi r_1^2 - \pi r_2^2 = \pi(r_1^2 - r_2^2)$
 $= \pi (r_1 + r_2) (r_1 - r_2)$
 $= 3.14 (1.8 + 1.0) (1.8 - 1.0)$
 $= 3.14 (2.8) (0.8)$
 $= 7.03 \text{ cm}^2$
 Area of 2 annuli = $2 \times 7.03 \text{ cm}^2$
 $= 14.06\text{cm}^2$

Therefore, the total surface area of the culvet ring
 $= 67.82 + 37.68 + 14.06$
 $= 225.06 \text{ cm}^2$

SELF ASSESSMENT EXERCISE 3

- i. Calculate the area of the curved surface of a cylinder of radius 7cm and height 10cm.
- ii. Calculate the total surface area of a solid cylinder of radius 2.8cm and height 10cm.

3.4 The Cone

A cone is a figure with circular base and its sides slanting to a common point or vertex. (see fig 6.14) typical examples include chiese hat or snail shell

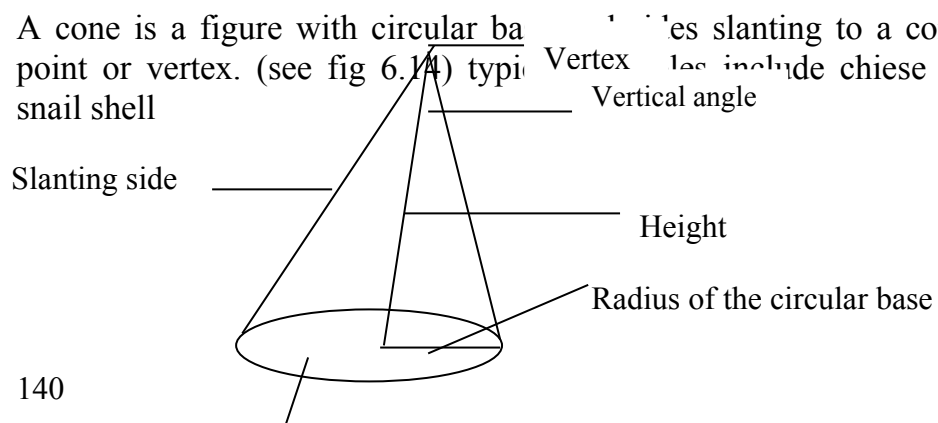

Fig. 6.14**3.4.1 Surface Area of A Cone**

Since a cone is formed from a sector of a circle, then the surface area of a cone is equal to the area of the sector that formed it.

The total surface area of a cone is the sum of (i) the curved surface area $\pi r l$ sq units and (ii) the area of the base of the cone πr^2 sq units.

The total surface area of a cone is $(\pi r^2 + \pi r l)$ sq unit
 $= \pi r (r + l)$ sq unit

Students should note that:

- i) When the total surface area of a cone is required the base is included.
- ii) When only the word surface area is used, it excludes the base.

Some simple examples would suffice to buttress the points which we are trying to put across.

Example 6.5

The slant edge of a right circular cone is 8cm and the diameter of the circular base is 6cm. Calculate the total surface area of the cone (take $\pi = 22/7$).

Solution

Fig. 6.15

Let $r = 6/2\text{cm} = 3\text{cm}$ and $l = 8\text{cm}$

$$\begin{aligned} \text{i) Area of the circular base} &= \pi r^2 \\ &= \frac{22}{7} \times 3 \times 3 = \frac{66}{7} \times 3 = \frac{198}{7} \\ &= 28.3\text{cm}^2 \end{aligned}$$

$$\begin{aligned} \text{ii) Area of the curved surface} &= \pi r l = \frac{22}{7} \times 3 \times 8 \\ &= \frac{528}{7} = 75.4\text{cm}^2 \end{aligned}$$

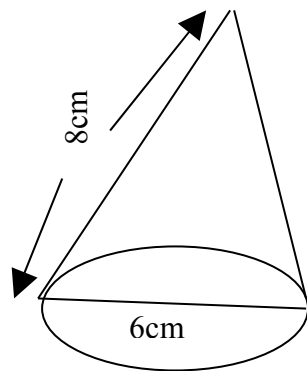
$$\begin{aligned} \text{The total surface area} &= (28.3 + 75.4)\text{cm}^2 \\ &= 103.7\text{cm}^2 \end{aligned}$$

SELF ASSESSMENT EXERCISE 4

Find the curved surface and total surface area of a cone of height 5 cm and radius 4cm (take $\pi = 22/7$)

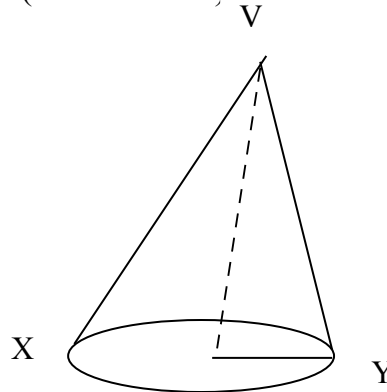
**Fig. 6.6.2**

3.5 Sphere

A sphere is the locus of points in space equidistant from one point called the center of the sphere. It should be noted that a sphere is different from a circle in that, the sphere is the locus of a point in space while the circle is the locus of a point in a plane. Examples of spherical objects are oranges, footballs, volleyball, basket balls, net balls etc.

when a sphere is divided into two equal sections, each half is known as a hemisphere.

3.5.1 Surface Area of a Sphere

In order to determine the surface area of the sphere, the expression,

The surface area of the sphere = $4\pi r^2$

This is the formula that is usually found in our textbooks as the surface area of a sphere. Hence this formula is employed whenever we are asked to calculate the surface area of a sphere

Example 6.6

Find the surface area of a sphere of diameter 56cm (take $\pi = 22/7$).

Solution

Surface area of a sphere = $4\pi r^2$ sq units

r = radius of sphere = $56/2 = 28$ cm and $\pi = 22/7$

Therefore, area of the sphere = $4 \times 22/7 \times (28)^2$ cm²

$$\begin{aligned} &= 4 \times \frac{22}{7} \times 28 \times 28 \text{ cm}^2 \\ &= 4 \times 4 \times 22 \times 28 \text{ cm}^2 \\ &= 9856 \text{ cm}^2 \end{aligned}$$

Example 6.7

Find the radius of a sphere whose surface area is 16100 cm² (take $\pi = 22/7$).

Solution

Surface area of sphere = $4\pi r^2$ sq units

There, $4\pi r^2 = 16100$ cm²

$$\pi r^2 = \frac{16100}{4} = 4025$$

$$r^2 = \frac{4025}{\pi} = 4025 \times \frac{7}{22} = 1280.6$$

$$r = \sqrt{1280.6} = 35.8 \text{ cm}$$

SELF ASSESSMENT EXERCISE 5

- i. Find the surface area of a sphere of diameter 28cm (take $\pi = 22/7$).
- ii. Determine the radius of a sphere whose surface area is 18400cm^2 ($\pi = 22/7$).

4.0 CONCLUSION

In this unit, you have been exposed to the methods and procedures for calculating the surface areas and curved surface areas of solid objects (especially 3 dimensional objects). These include prism, pyramid, cylinders and cones. You also learnt about the total surface areas of spheres. Our understanding of the areas of plane shapes was used to provide basis for the learning of the content of this unit.

5.0 SUMMARY

In this unit you have learnt about the following:

- The total surface area of a prism is given by the sum of the area of the rectangles and the triangle that make up the prism, say in a triangular prism
- The total surface area of a rectangular prism is the sum of the areas of all the rectangular plane shapes that make up the prism.
- The total surface area of a pyramid with rectangular base is the sum of the areas of the five faces namely (i) the rectangular face (ii) the triangular faces.
- There exist two forms of cylinders viz, closed and open cylinders
- The total surface area of a closed cylinder is $2\pi(r + h)$
- The total surface area of a cone is the sum of the area of the circular base πr^2 and area of the curved surface $\pi r l$

6.0 TUTOR-MARKED ASSESSMENT

1. Define (i) a Cone (ii) a sphere (iii) a pyramid (iv) a cylinder.
2. Distinguish clearly between a sphere and a circle.
3. Find the radius of a sphere whose surface area is 15400cm^2 (take $\pi = 22/7$).
4. Calculate the total surface area of a cone with slanting edge of 10cm, and circular base diameter of 6cm.

7.0 REFERENCES/FURTHER READINGS

Olayanju, S. O. and Oyewobi, G. O. (1998). *Geometrical Shape and Measurements*. Lagos: SIBIS Ventures.

Osiagwu D. M. N. Anemeli C. and Onyeozili I, (2004). *New school Mathematic for Senior Secondary Schools*. African a First Publishers Limited.

UNIT 4 VOLUME OF SIMPLE SOLIDS

CONTENTS

- 1.0 Introduction
- 2.0 Objectives
- 3.0 Main Content
 - 3.1 Meaning of Volume
 - 3.2 Volume of Prism
 - 3.3 Volume of Cylinder
 - 3.4 Volume of Cone
 - 3.5 Volume of Pyramid
 - 3.6 Volume of Sphere
- 4.0 Conclusion
- 5.0 Summary
- 6.0 Tutor-Marked Assignment
- 7.0 References/Further Readings

1.0 INTRODUCTION

In Unit six of this Module, our effort was directed at determining the surface areas, curved surface areas and total surface areas of three dimensional solids. These include prisms, cylinders, cone with the volumes and the determination of the volumes of these objects and figures.

2.0 OBJECTIVES

At the end of this unit, students should be able to:

- defined volume of a solid object
- derive the formula for the volume of prism
- apply this formula to calculate the volume of a prism
- determine the volume of a cylinder
- determine the volume of a cone
- calculate the volume of a pyramid
- find the volume of a sphere.

3.0 MAIN CONTENT

3.1 Meaning of Volume

In the simplest sense, volume of a solid refers to the space occupied by that solid. It can also be defined as the space a substance occupied in a container or the amount of substance in a container. Volume involves 3-dimensional objects but not two dimensional objects (I.e. plane objects/figures have no depth).

3.2 Volume of Prism

The volume of a prism is the area of its cross-section multiplied by the distance between the end faces. For instance, the volume of triangular prism is equal to the area of cross section x distance between the end faces (see fig 7.1) = area of $\Delta CDE \times BE$

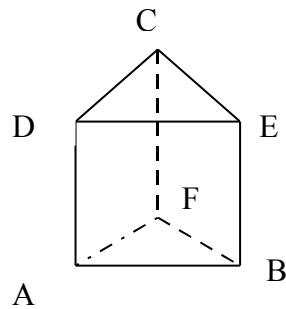
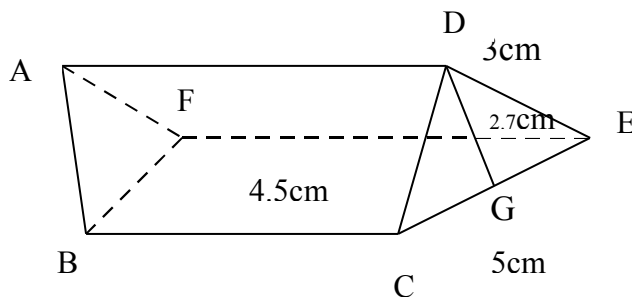

Fig. 7.1 Triangular Prism

Example 7.1

Find the volume of the triangular prism in the diagram below:



Solution

Volume of prism = area of cross section x distance between the end faces. Here the end faces are triangles: so the area of CDE will be calculated thus:

$$\begin{aligned} \text{Area of CDE} &= \frac{1}{2} \times CE \times DG, \text{ where DG is the height of the } \Delta \\ &= \frac{1}{2} \times 5 \times 2.7 \text{ cm}^2 = \underline{13.5} \text{ cm}^2 \\ &= 6.75 \text{ cm}^2 \end{aligned}$$

$$\begin{aligned} \text{Volume of prism} &= \text{Area of } \Delta \text{ CDE} \times BC. \\ &= 6.75 \times 4.5 \text{ cm}^3 \\ &= 30.375 \text{ cm}^3 \end{aligned}$$

Therefore, the volume of triangular prism = 30.4cm^3

Example 7.2

The cross section of a trapezoidal prism 9.6cm long is as given in the diagram (fig 7.3). Find the volume of the prism

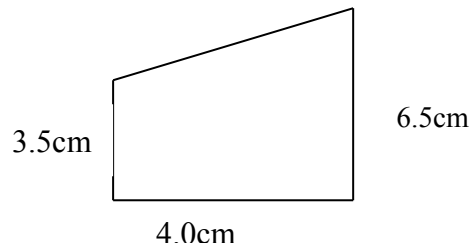

Fig 7.3

Solution

Volume of prism = area of cross-section \times distance between the end faces

Area of cross-section = area of trapezium

= $\frac{1}{2}$ (sum of parallel sides \times height)

= $\frac{1}{2}$ sum of parallel sides \times height).

= $\frac{1}{2}$ (3.5 + 6.5) \times 4.0cm.

= $\frac{1}{2}$ (10) \times 4.0

= 5 \times 4

= 20cm^2 .

Therefore, the volume of prism = $20\text{cm}^2 \times 9.0$ where 9.0 is the distance between the end faces or the length of the solid.

$$20 \times 9.0 = 180\text{cm}^3$$

SELF ASSESSMENT EXERCISE 1

- i. Find the volume of a triangular prism, 10.5cm long and having triangular face of dimensions 9.8cm by 5.8cm and 6.8cm.
- ii. The figure below shows the cross section of a trapezoidal prism 8.5cm long. Find the volume

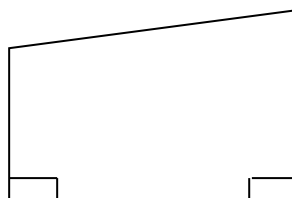

4.5

3.5

3.6

Fig 7.4**3.3 Volume of Cylinder**

As discussed in Unit six of this Module, there are two main kinds of cylinder

- (i) Right Circular cylinder
- (ii) Thick hollow cylinder

- (a) The right circular cylinder (see fig 7.5) is a solid of uniform cross section is a circle. Thus, if the height of a cylinder = h units and the base radius = r units, then the volume of the cylinder,

Area of base x height

$\pi r^2 \times h$ cubic units

$\pi r^2 \times h$ cubic units

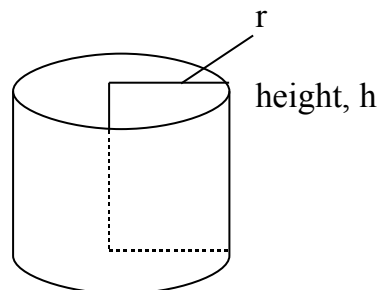
**Fig 7.5****Example 7.3**

Find the volume of a closed cylinder of radius 4.5cm and length 8.5 (take $\pi r = 3.14$).

Solution

Volume = area of base x height

$$= \pi r^2 \times h$$

$$= \pi r^2 \times (4.5)^2 \times 8.5 \text{ cm}^3$$

$$= 3.14 \times (4.5)^2 \times 8.5 \text{ cm}^3$$

$$= 540.5 \text{ cm}^3$$

(b) Thick hollow cylinder

In the case of a thick hollow cylinder, the volume of the cylinders is equal to the difference between the two cylinders formed within (see fig. 7.6)

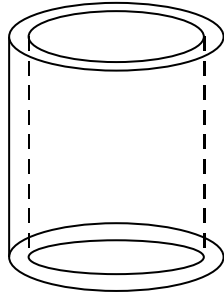

Fig. 7.6: Thick Hollow Cylinder

Example 7.4

Find the volume of the cylindrical tubes of length 5cm, external diameter 3.6 cm and internal diameter 2.4cm.

Solution

Volume of cylindrical tube = volume of cylinder of diameter 3.6cm –
volume of cylinder of diameter 2.4cm

$$\text{External radius } r_1 = \frac{3.6}{2} = 1.8 \text{ cm}$$

$$\text{Internal radius } r_2 = \frac{2.4}{2} = 1.2 \text{ cm}$$

$$\text{Volume of cylinder of radius 1.8cm} = \pi r^2 h$$

$$\text{Volume of cylinder of radius 1.2cm} = \pi r^2 h$$

$$\text{Therefore, volume of cylinder} = \pi r^2 h - \pi r^2 h \text{ cubic units}$$

$$= \pi h (r^2 - r^2) \text{ cubic units}$$

$$= (3.14 \times 5) (1.8)^2 - (1.2)^2 \text{ cubic unit}$$

$$= 15.7 (3.24 - 1.44) \text{ cubic unit}$$

$$= (15.7 \times 1.8) \text{ cm}^3$$

$$= 28.26 \text{ cm}^3$$

$$\text{Approximately} = 28.3 \text{ cm}^3 \text{ (1.d.p.)}$$

SELF ASSESSMENT EXERCISE 2

- i. Calculate the volume of a cylindrical object with base diameter of 8cm and length 8cm.
- ii. Find the volume of a culvert ring of length 10cm, external diameter 6.4cm and internal diameter of 4.6cm

a. Volume of Cone

In Unit six of this Module, you have learnt that a cone is a shape with two surfaces, the base and the curved surface. In order to have a good understanding of how the formula for the volume of a cone is determined, let us construct a model of a cone and a cylinder with equal base and equal height. Fill the cone with sand and empty it into the cylinder. It will be seen that the cylinder is thrice the volume of a cone.

Now the volume of cylinder as seen earlier = $\pi r^2 h$.

Therefore, the volume of a cone = $\frac{1}{2} \pi r^2 h$

Examples 7.5 and 7.6 suffice to further buttress the application of this relation.

Example 7.5

Find the volume of a right-circular cone of slant edge 10.6 and base diameter of 5.6cm (take $\pi = 3.14$).

Solution

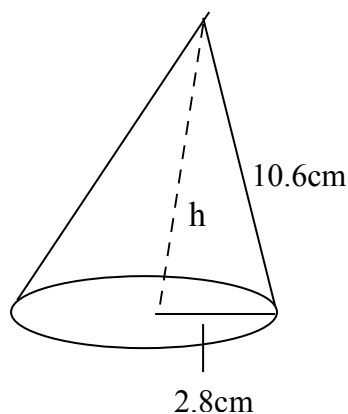

$$\begin{aligned}
 h^2 &= (10.6)^2 - (2.8)^2 \\
 &= (10.6 + 2.8)(10.6 - 2.8) \\
 &= (13.4)(7.8) \\
 h &= \sqrt{104.5} \\
 &= 10.2\text{cm.}
 \end{aligned}$$

2. Volume of cone = $\frac{1}{3} \pi r^2 h$
 $= \frac{1}{3} \times 3.14 \times (2.8)^2 \times 10.2$

$$= 1/3 \times 251.1$$

$$= 83.70\text{cm}^3$$

Example 7.6

The slanting side of a cone is 10cm long. The base radius is 8cm calculate the volume of the cone.

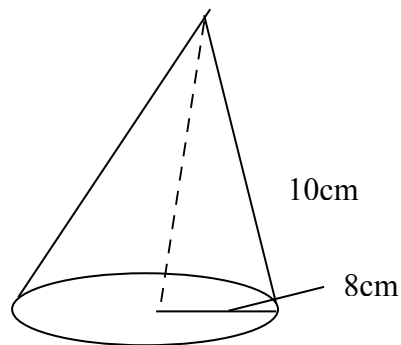
Solution

$$\text{Volume of cone} = 1/3 \pi r^2 h$$

$$\text{But } h^2 = 10^2 - 8^2 = 100 - 64$$

$$= 36$$

$$h = \sqrt{36} = 6$$

$$\text{Now } r = 8\text{cm}$$

$$\text{Volume of the cone} = 1/3 \times 3.14 \times 8 \times 8 \times 6$$

$$= 40.92\text{cm}^3$$

SELF ASSESSMENT EXERCISE 3

The slant side of a cone is 10cm long. The basic radius is 6cm. Calculate the volume of the cone.

b. Volume of Pyramid

A pyramid as we have seen earlier on, is shaped almost like a cone having a polygonal base (see figure 7.6), while the cone has a circular base then the volume of the pyramid is also $1/3$ base area \times height

Therefore, volume of pyramid = $1/3$ the product of base area \times height

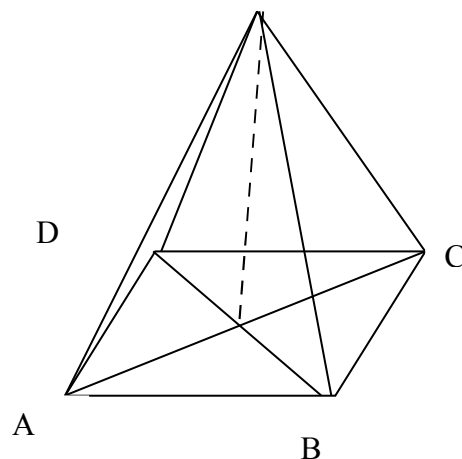

Fig. 7.6

Example 7.7

Find the volume of the right pyramid with vertex v and a rectangular base measuring 6.4cm by 5cm and a height of 9cm in figure 14.7.

Solution

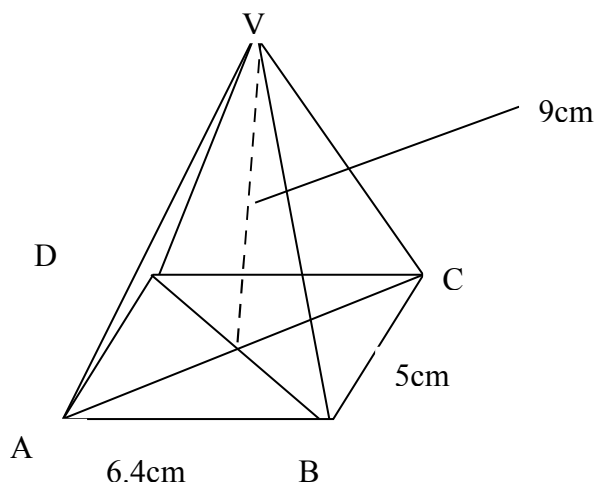

Fig. 7.7

$$\begin{aligned}
 \text{Volume of pyramid} &= \frac{1}{3} \text{ area of base} \times \text{height} \\
 &= \frac{1}{3} AB \times BC \times VE \\
 &= \frac{1}{3} 6.4 \times 5 \times 9 \\
 &= 6.4 \times 5 \times 3 \\
 &= 6.4 \times 15 \\
 &= 96\text{cm}^3
 \end{aligned}$$

Example 7.8

Find the volume of a pyramid with a triangular base of sides 8cm by 5cm by 9cm and a height 11.6cm.

Solution

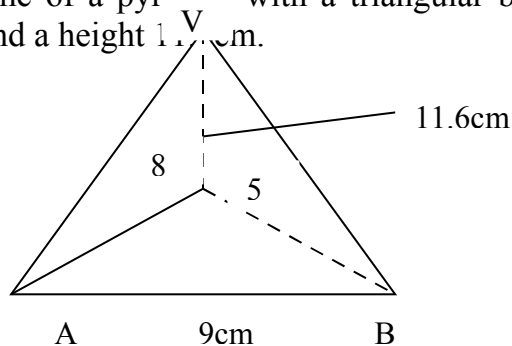

Fig 7.8

Using the Hero's formula for finding the area of a triangle

$$\text{Area of ABC} = \sqrt{s(s-a)(s-b)(s-c)}$$

$$\text{Where } s = \frac{a + b + c}{2} = \frac{9 + 5 + 8}{2} = \underline{11} = 11\text{cm}$$

$$\begin{aligned} \text{Area of ABC} &= \sqrt{11(11-9)(11+8)(11-5)} \\ &= \sqrt{11(2)(3)(6)} \\ &= \sqrt{11 \times 36} \\ &= \sqrt{396} \\ &= 19.90 \text{ cm}^2 \end{aligned}$$

$$\begin{aligned} \text{Volume of pyramid} &= \frac{1}{3} \times \text{base area} \times \text{height} \\ &= \frac{1}{3} \times 19.90 \times 11.6 \\ &= \underline{\underline{230.84}} \\ &= 76.95 \text{ cm}^3 \end{aligned}$$

SELF ASSESSMENT EXERCISE 4

Find the volume of a right pyramid with a square base if the height is 15.7cm and the length of a slant edge is 18.2cm.

c. Volume of Sphere

In order to determine the volume of a sphere, let us carry out the following activities. This would assist in having clearer view about how the formula for calculating the volume of a sphere is arrived at. Now cut a hollow ball vertically and horizontally into 4 equal with 2 open surfaces as shown in figure 7.8 below:

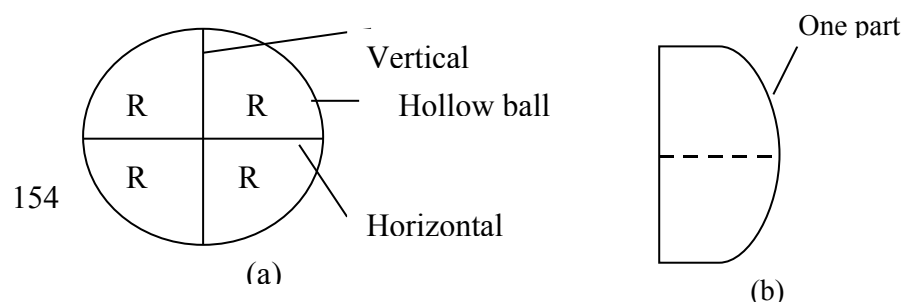

Fig. 7.8

Then take one part and join the two surfaces to form a solid that resembles a cone. Note that the radius of the ball R is equal to the height h and the base radius r of the cone formed (i.e. $R = h = r$). But the volume of a cone = $\frac{1}{3} \pi r^2 h$, where h is the height and r is the base radius of the cone.

So, the volume of the cone formed = $\frac{1}{3} \pi R^3$ (since $R = h = r$)
 Since there are 4 equal parts of the ball, there are 4 such cones.

Therefore, volume of the entire ball = $4 \times \frac{1}{3} \pi R^3 = \frac{4}{3} \pi R^3$ cubic unit.

Since a ball is spherical, it follows therefore that the volume of a sphere is derived thus.

Hence volume of sphere = $\frac{4}{3} \pi R^3$ cubic unit, where R is the radius of the sphere.

Let's now solve one or two examples to actually drive home the point.

Example 7.9

Calculate the volume of a sphere with radius 6.4cm (take $\pi = 3.14$).

Solution

$$\begin{aligned} \text{Volume of sphere} &= \frac{4}{3} \pi r^3 \text{ cubic units.} \\ &= \frac{4}{3} \times 3.14 \times (6.4)^3 \text{ cm}^3 \\ &= \frac{4 \times 823.13}{3} = \frac{3292.5}{3} \\ &= 1097.5 \text{ cm}^3 \end{aligned}$$

Example 7.10

Calculate the volume of a material in a hollow hemisphere of external diameter 16cm and internal diameter 14cm (take $\pi = 3.14$).

Solution

A hemisphere = $\frac{1}{2}$ of a sphere.

The internal diameters of the hollow hemisphere are equal to the diameter of the cavity.

Therefore radius of cavity $r_2 = 14/2 = 7$ cm

External radius of the hemisphere $r_1 = 16/2 = 8$ cm

Volume of the hemisphere in the hollow hemisphere = $\frac{1}{2}$ (volume of the sphere radius 8cm volume of the sphere radius

$$\begin{aligned}
 &= \frac{1}{2} (4/3 \pi r_1^3 - 4/3 \pi r_2^3) \text{ cubic unit} \\
 &= \frac{1}{2} \times 4/3 \pi (r_1^3 - r_2^3) \\
 &= \frac{1}{2} \times 4/3 \times 3.14 (8^3 - 7^3) \\
 &= 2/3 \times 3.14 (512 - 343) \\
 &= \frac{6.28 \times 169}{3} = \frac{1061.32}{3} \\
 &= 353.77
 \end{aligned}$$

Therefore, the volume of materials in the hollow hemisphere is 353.77cm^3 .

SELF ASSESSMENT EXERCISE 5

- i. Calculate the volume of the sphere with radius 4.2 (take $\pi = 3.14$).
- ii. Determine the volume of materials in a hollow hemisphere of external diameter 18cm and the internal diameter 16cm (take $\pi = 3.14$).

4.0 CONCLUSION

In this unit you have learnt about volumes of solids 3-dimensional figures. You have equally learnt about the procedures for determining the volumes of these objects. You also gained the idea about how the formula for finding the volumes of these dimensional solids were arrived at while typical examples of how the formulae could be applied were also treated to drive home the points.

5.0 SUMMARY

In this unit you have been exposed to the following:

- That the volume of a particular solid is the space occupied by the solid.
- Volume of a triangular prism = area of triangular base x height
- Volume of a trapezoidal prism = area of cross section (trapezium) x dist between end faces
- Volume of a cylinder = $\pi r^2 h$
- Volume of a hollow cylinder = difference between the volumes of the external cylinder and internal cylinders
- Volume of a cone = $\frac{1}{2} \pi r h$
- Volume of a pyramid = $\frac{1}{3}$ x base area x height
- Volume of a sphere = $\frac{4}{3} \pi r^3$

6.0 TUTOR-MARKED ASSIGNMENT

1. Define volume of a solid
2. The diameter of a cylindrical tin is 6cm and the height is 16cm. What is the volume of the tin? (take $\pi = 3.14$)
3. Find the volume of a sphere with the following dimensions (i.e. diameter) $\pi = 3.14$
 - (i) 8.6 cm
 - (ii) 6.4 cm

7.0 REFERENCES/FURTHER READINGS

Obiona G et al (1994). *STAN Mathematics for Junior Secondary Schools*. University Press.

David-Osiagwu, M. N. Anemelu, C. and Onyeozili (2004). *New School Mathematics for Senior Secondary Schools*. Lagos: Africana First Publishers.

UNIT 5 SIMPLE GEOMETRIC CONSTRUCTIONS

CONTENTS

- 1.0 Introduction
- 2.0 Objectives
- 3.0 Main Content
 - 3.1 Bisection of a Straight Line
 - 3.2 Bisection of an Angle
 - 3.3 Construction of a Perpendicular to a line
 - 3.4 Construction of Angle 90°
 - 3.5 Construction of Angle 60°
 - 3.6 Construction of Equilateral Triangle
 - 3.7 Construction of Isosceles Triangle
 - 3.8 Construction of a Scalene Triangle
 - 3.9 Points to Note on Construction of Triangles
 - 3.10 Construction of Angle is Equal to a Given Angle
 - 3.11 More Constructions
 - 3.12 Locus of a Point
- 4.0 Conclusion
- 5.0 Summary
- 6.0 Tutor-Marked Assignment
- 7.0 References/Further Readings

1.0 INTRODUCTION

In the last few units of this course, efforts have been made to discuss into some details line, figures and shapes of solid objects. This unit is going to be dedicated to simple constructions. This is borne out of the need for students offering this course to know about simple constructions. It is also important for students to note that the difference between the terms ‘draw’ and ‘construct’ in geometry is that in ‘construct’ only the ruler and a pair of compasses are used while in “draw” any instrument considered necessary in making such drawing can be used. So, in this unit our focus is on construction and perhaps loci.

2.0 OBJECTIVES

At the end of this unit, students should be able to:

- distinguish between drawing and construction
- bisect any given line or angle
- construct a triangle
- define the locus of a point
- give some examples of common 2-dimensional loci.

3.0 MAIN CONTENT

3.1 Bisection of a Straight Line

In order to bisect a given straight line, you would need a ruler and a pair of compasses. In order to carry out the bisection the following procedural steps are followed

Given: A straight line.

Required: - To bisect it, i.e. to divide it into two equal parts.

Construction: - With A as the center and any convenient radius, make arc of a circle above and below the line AB. Then with B as center and the same radius make an arc above and below to cut the first set of arc at X and Y respectively. This is as shown in figure 8.1. Then join XY to cut the line AB through O. The line is bisected at O i.e. $AO = BO$

The line XY is sometimes called the perpendicular bisector of the line AB. This is because $\angle ADX = \angle BOX = 90^\circ$ (rt angle).

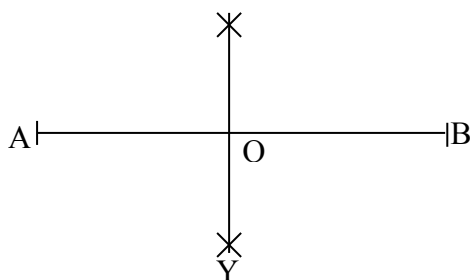

Fig. 8.1

3.2 Bisection of an Angle

In constructing a line to bisect an angle as in section 8.3, a pair of compasses, a ruler and sharpened pencil will be required. The following procedural steps are followed

Giving $\angle ABC$

Required: - to bisect the $\angle ABC$

Construction: - With B as center and any reasonable radius make arcs to cut the lines AB and AC at M and N respectively with M as center and any convenient radius make an arc of a circle. With N as center and the same radius make another arc to cut the first arc at Q, (see figure 8.2) join BQ. The line BQ is called a bisector of $\angle ABC$. It bisects $\angle ABC$. This means that $\angle ABQ = \angle CBQ$

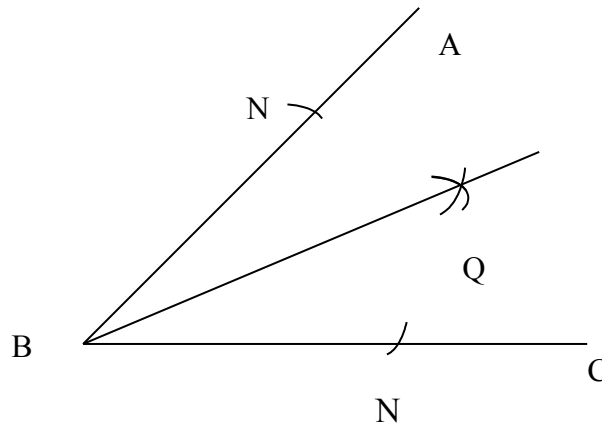

Fig 8.2

SELF ASSESSMENT EXERCISE 1

- i. Draw any angle of your choice and show the bisector of the angle
- ii. State the procedure for arriving at this bisection.

3.3 Construction of a Perpendicular to a Line

In doing this kind of construction, there are two possibilities. The perpendicular line can be from

- i) a point X to the line
- ii) a point X outside the line

The same set of materials or construction instruments are needed as those in the preceding sections.

- i) a perpendicular from a point X on the line

Let the line be AB. With X as center and a reasonable radius, draw arcs to cut AB at M and N. Then with M and N as centers and same radius, draw arcs to meet at Y. Then join XY. XY is the required perpendicular from the point XY to AB. (see fig 8.3)

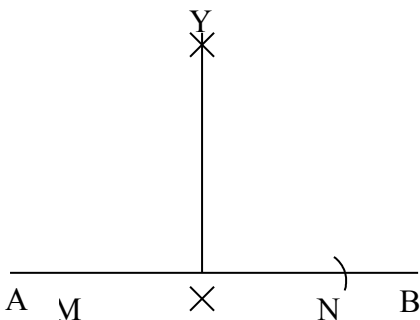

Fig. 8.3

ii) A perpendicular from a point X outside the line

Let the line be AB with X as center and any convenient (or reasonable) radius make an arc, cutting the line AB at P and Q. Then, with P and Q as centers and the same radius make arcs cutting each other at Y (see figure 8.4). Then join XY. XY is the required perpendicular to the line AB.

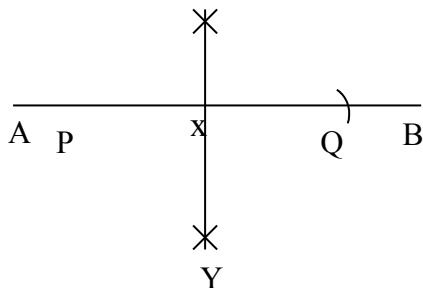

Fig. 8.4

3.4 Construction of Angle 90°

Students should note that the constructions of an Angle of 90° uses the same method used for the construction of a perpendicular to a line. Shown in figure 8.3 since $\angle YXB = 90^\circ$.

3.5 Constructions of Angle 60°

Draw a line of reasonable length AB with A as center and a convenient radius make an arc of a circle cutting the line AB at S. with S as center and the same radius make another arc cutting the first arc at T (see figure 8.5). Then join AT. $\angle TAS$ is 60°

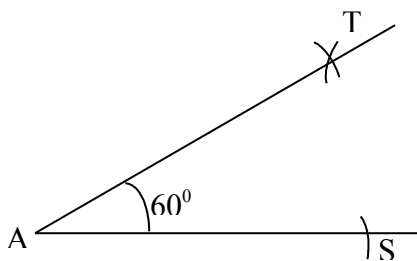

Fig. 8.5

3.6 Construction of an Equilateral Triangle

This is same as the construction of an angle of 60° but here join ST as well as AT. The triangle AST is equilateral. As equilateral triangle is a triangle with all angles equal

Construction of an Angle of 120°

The procedure for the construction of an angle 120° is given thus:

Draw line of reasonable length AB. with center A and with convenient radius draw an arc to cut line AB at X.

With X as center and same radius AX draw another arc to intersect the first at Y. With Y as the center and same radius AX, draw the third arc to meet the first E. Then join EA (see fig 8.9) ($\angle BAE$ is 120°).

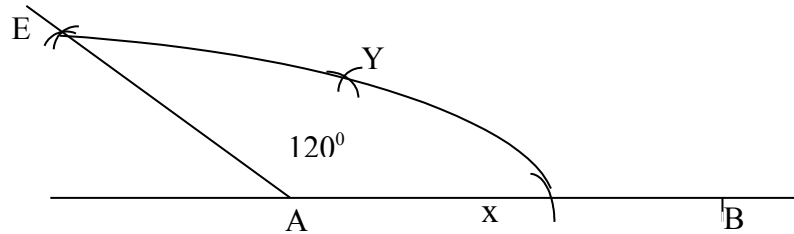

Fig. 8.6

SELF ASSESSMENT EXERCISE 2

Describe how you would construct angle 120° .

3.7 Construction of an Isosceles Triangle

An isosceles triangle is a Δ with two of its three sides equal and the two angles facing the equal sides, equal too. Let's now try to construct this kind of triangle.

Given: -A line A B.

Construction: -with A as center and any suitable radius not equal to AB, make an arc of a circle, with B as center and the same radius make another arc cutting the first arc at C then join AC and CB. ΔABC is an isosceles and $AC = BC$, radii of equal circle see fig 8.7.

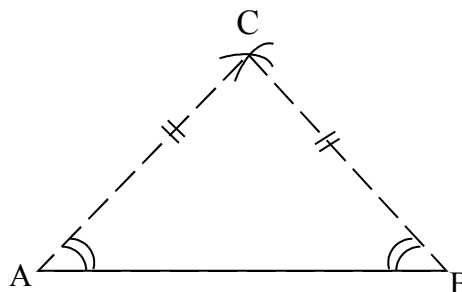

Fig. 8.7

- a) Construction of an Angle of 30°

First construct an angle of 60° (see figure 8.5), then bisect the angle (see figure 8.2)

$\angle QAC = 30^\circ$ and $\angle CAR = 30^\circ$ see figure 8.8

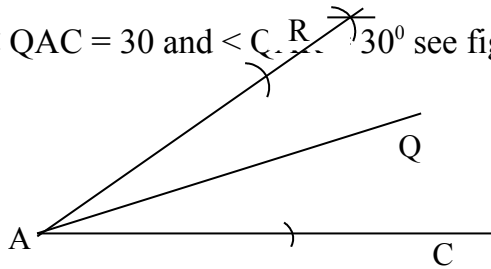

Fig 8.8

- b) Construction of an angle of 45°

Here first construct an angle YXB of 90° (see fig. 8.8)

Then bisect it (see figure 8.2) $\angle PXY = \angle PXB = 45^\circ$ see figure 8.9

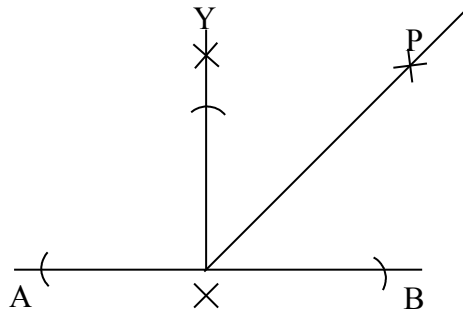

Fig. 8.9

SELF ASSESSMENT EXERCISE 3

Draw a line segment of any length, draw

- i) A perpendicular on the line.
- ii) A perpendicular from a point outside the line.

3.8 Construction of a Scalene Triangle

In a scalene triangle all the three sides have different length. Procedure for the construction of this type of triangle is described as follow:

Given: - A line AB

Required: -To constructs a scalene triangle on it.

Construction:- With A as center and any reasonable radius not equal to AB, make an arc. With AB as center and another radius different from the first one, but still not equal to AB, make another arc cutting the first arc at C (see fig 8.10). Join AC, ABC is scalene and $AB \neq AC \neq BC$.

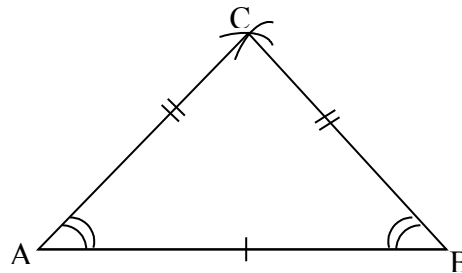

Fig 8.10: A Scalene Triangle

3.9 Points to Note on Construction of Triangles

In the construction of triangles, three measures or elements out of the six elements of a triangle (i.e. 3 sides and 3 angles) must be given. One of the given elements must be a side. Once 3 elements including at least one side of any triangle are known the triangle can be constructed. Going by the series of constructions, which we have treated in this unit, students should by now be able to construct the following angles by following the steps discussed so far or their combinations - an angle of 30° , 45° , 60° , 90° .

Angle of 120° (see fig. 8.6).

135° – A combination of $<90^\circ$ and $<45^\circ$ on a straight line. Thus by successive bisections and combination of the above angle a student can obtain angles of 15° , $22\frac{1}{2}^\circ$, $67\frac{1}{2}^\circ$, 75° and even smaller or larger angles

SELF ASSESSMENT EXERCISE 4

Construct a triangle XYZ such that $XY = 10\text{cm}$, $XZ = 8\text{cm}$ and angle $XYZ = 105^\circ$; Determine the length of YX.

3.10 Construction of an Angle Equal to a Given Angle

Let angle CAB be the given angle. Draw any straight line XY with A and X as centre and any same suitable radius draw two arcs cutting AB and AC at P and Q respectively and XY at O. Then with O as center and PQ as radius, draw an arc cutting the arc on XY at Z. Join XZ and produce to K. Angle KXY = Angle CAB (see figure 811).

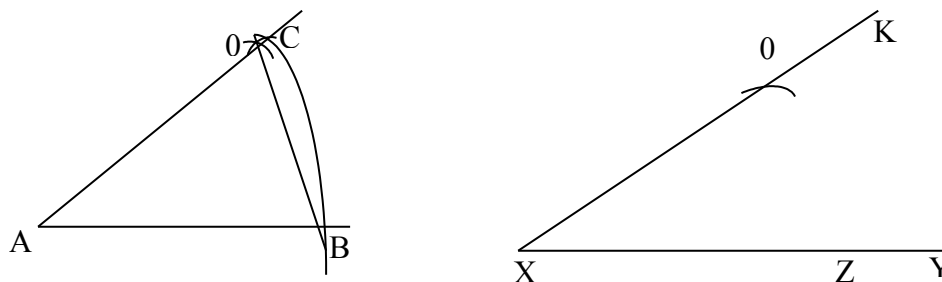

Fig 8.11

3.11 More Constructions

(a) **To Construct a Line Parallel to a given Line passing through a given Point**

Let AB be the given line and X the given point. Take any point Y on AB join XY. At the point X construct an angle YXQ to the angle BYX using the method of construction for an equal angle above. The other arm QX of $\angle YXQ$ is parallel to AB since equal angles are alternate to each other. (see figure 8.12).

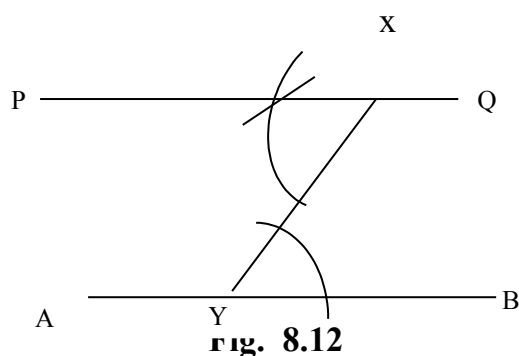

Fig. 8.12

Alternatively, the construction of a line parallel to a given line and passing through a given point can be carried out by using rules and a set-square. The method is as shown in figure 8.13. This is done by putting a set square so that one edge is along the ruler and one edge along AB, the given line. (see figure 8.13). Slide the set-square along the ruler as shown in the figure until the edge to the set-square originally placed

along AB passes through X. Draw the line along the edge of the set square. The line PXQ is parallel to AB.

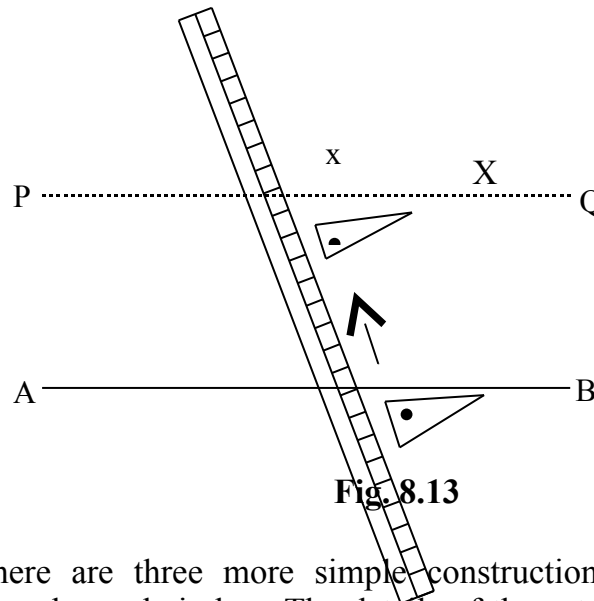

Fig. 8.13

- (b) There are three more simple constructions, which deal with triangles and circles. The details of those types of constructions will not be dealt with here in this course. In some other courses, the details of these constructions would be extensively treated. These constructions are.
- i) The circumscribed circle of a given triangle
 - ii) The inscribed circle of a given triangle and
 - iii) The E-scribed or escribed circle of a given triangle

Let us now define each of these kinds of constructions as shown in figures 8.14.1, 8.14.2 and 8.14.3.

Definitions

- i) The circumscribed circle of a triangle ABC is the circle passing through the vertices A, B, and C of the triangle ABC and circumscribing or enclosing the triangle. In simple term, the circle is regarded as the circum-circle. This is shown in figure 8.14.1

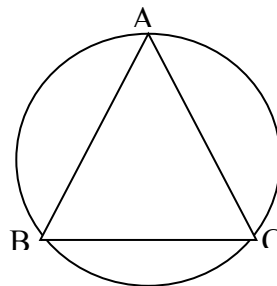

Fig. 8.14.1

- ii) The inscribed circle of a triangle XYZ is the circle which is inscribed or enclosed by the triangle and having the sides X, YZ and ZX of the triangle as tangents to the circle. This inscribed circle is called the in-circle. See figure 8.14.2.

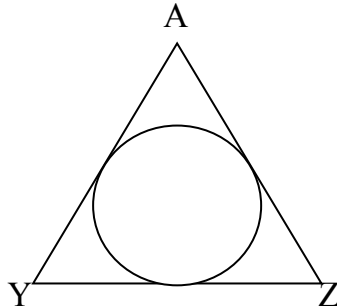

Fig. 8.14.2

- iii) The E-scribed circle of a triangle ABC is the circle outside the triangle as shown in figure 8.15 with the three sides of the triangle (some produced) as tangents to the circle. The circle is exterior to the triangle and called the ex-scribed circle. While there can be only one circum-circle and only one in-circle for any triangle there are three possible ascribed circles to any triangle since any two of the 3 sides can be produced (see figure 8.16). In the simplest sense, the escribed circle can be called the e-circle. In order to distinguish which of the three possible e-circles is meant we associate the e-circle with the unproduced side of the triangle, which is its tangent (i.e. the side of the triangle not produced). For example, figure 8.16 show the circle center, X is escribed to the side AC of the triangle while the circle center Y is scribed to the side AB and the circle center Z escribed to the side BC.

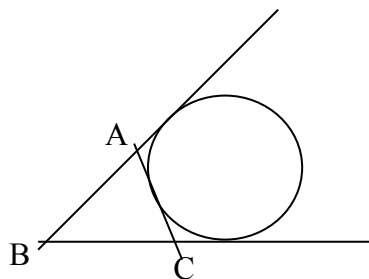

Fig. 8.15

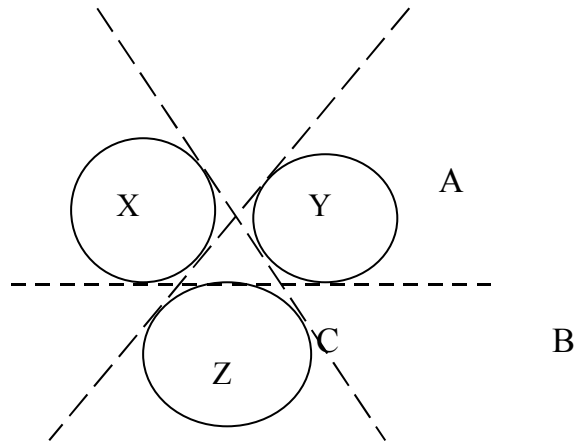

Fig. 8.16

3.12 Locus of a Point

The locus of a point is the path traced by that point under specific conditions. All points on that path satisfy the specific condition(s). The plural of locus is loci.

Example of some common 2-dimensional loci

- (i) The locus of a point which moves with a constant distance from a fixed point in a plane is a circle; with the fixed point as the center and the constant distance as the radius. This is illustrated in figure 8.17.

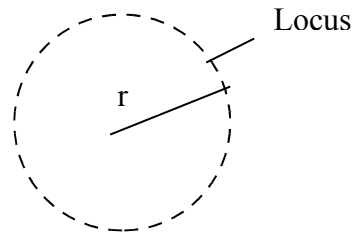

Fig. 8.17

- (ii) If the point can move anywhere in space with the constant distance from a fixed point O , then the locus is a sphere with O as the center, and r , the constant distance as the radius of the sphere.
- (iii) The locus of a point in a plane, which is always equidistant from two fixed points, is the perpendicular bisector of the line joining the two points. (see fig. 8.18).



Fig 8.18

- (iv) The locus of a point in the plane which is equidistant from two given intersecting lines ABC and XBY (see fig. 8.19) is the pair of dotted lines PBQ and SBT which bisect the angles between ABC and XBY i.e. loci, these loci are the angular bisectors of these angles between the lines.

Note that, these loci, i.e. lines are perpendicular to each other. Thus, if PQ and ST as in fig 8.19 bisect angles YBC and ABY respectively then PQ is perpendicular to ST.

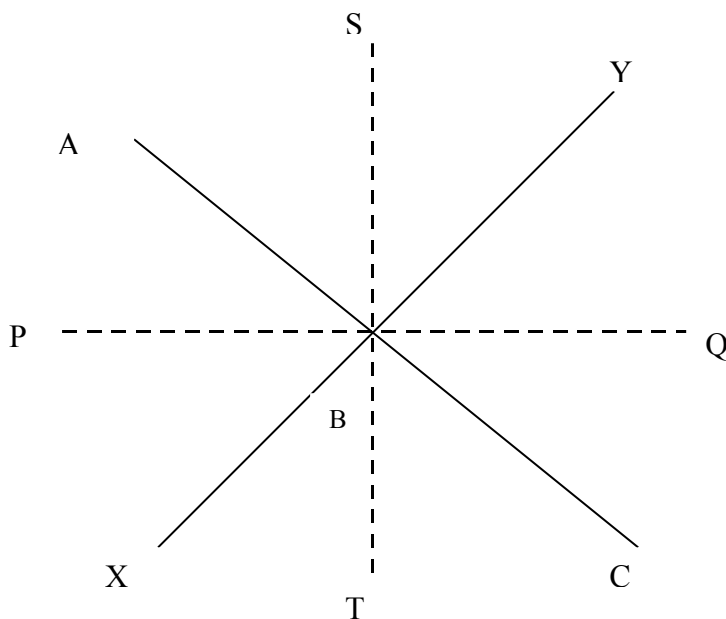

Fig 8.19

SELF ASSESSMENT EXERCISE 5

Describe the following loci and also sketch them

- The locus of a point P which moves on one side only of a straight line AB so that the angle XPY is constant
- If the constant angle in (a) above is a right angle, what is the locus?

4.0 CONCLUSION

In this unit, we have discussed simple treatment of constructions in relation to the demand of this course. Other forms of more complex constructions transcends the scope of this course. Hence, their exclusion from our discussion in this course. Students who are interested in learning these more complex constructions could consult some of the suggested readings at the end of this unit. Efforts were also made at defining and discussing some simple forms of loci of points.

5.0 SUMMARY

In this unit you have learnt about the following.

- That in construction only ruler and a pair of compasses are used as against drawing that involves specific instrument necessary for making such drawings
- In construction, the following are possible:
 - Bisection of a straight line
 - Construction of a perpendicular to a line
 - Bisection of an angle
 - Construction of angles such as 45° , 60° , 90° , etc.
 - Bisection of angles
 - Construction of triangles such as equilateral, scalene and isosceles triangles
 - Construction of parallel lines

That a locus of a point is the path traced by that point under specific conditions

- That the locus of a point, which moves with a constant distance, from a fixed point in a plane is a circle.

The locus of a point that can move anywhere in space with the constant distance from a fixed point O , is a sphere with the center O

The locus of a point in a plane, which is always equidistant from two fixed points, is the perpendicular bisector of the two points. The locus of a point which is equidistant from two given intersecting lines are the angular bisectors of the angle between the lines.

6.0 TUTOR-MARKED ASSIGNMENT

1. Distinguish between 'construction' and 'drawing'.
2. With a pair of compasses, ruler and sharpened pencil construct the following angles (a) 60° (b) 120° .
3.
 - a) what is the locus of a point?
 - b) sketch the locus of a point in space moving with a constant distance from that fixed point. Name the product.

7.0 REFERENCES/FURTHER READINGS

David –Obiagwu M. N, Anemelu Chinwa and Onyeozili, I. (2004). *New School Mathematics for Senior Secondary Schools*. Lagos: African First Publishers.

Olayanju, S. O. and Olaosunde, G. R. (2001). *Teaching Primary Mathematics Curriculum and Shapes Measurement*. Lagos: SIBIS Ventures.