



NATIONAL OPEN UNIVERSITY OF NIGERIA

SCHOOL OF SCIENCE AND TECHNOLOGY

COURSE CODE: CIT 656

COURSE TITLE: OPERATIONS RESEARCH

CIT 656 OPERATIONS RESEARCH

COURSE GUIDE



NATIONAL OPEN UNIVERSITY OF NIGERIA

Course Code	CIT 656
Course Title	Operations Research
Writer Team	Arowolo O. School of Science and Technology Lagos State Polytechnics. Ikorodu.
Content Editor	Dr. Abiola B. School of Science and Technology National Open University of Nigeria



NATIONAL OPEN UNIVERSITY OF NIGERIA

Contents

Introduction

The Course

Course Aims and Objectives

Working through the Course

Course material

Study Units

Textbooks

Assessment

Tutor Marked Assignment

End of Course Examination

Summary

INTRODUCTION

You would have become familiar with basic Operations Research concepts introduced to you in your undergraduate course and which ostensibly has encouraged you to develop an enquiring attitude towards Operations Research applications which abound and decisions based on these principles which affect the decisions you make every single day.

It is the objectives of this course to build upon the prior lessons learnt, and formally to introduce to you the more advanced concepts with the view to reinforcing your understanding and placing you in a pivotal position to intellectually understand developmental work and research in the rapidly advancing field of Operations Research.

THE COURSE: CIT 656 OPERATIONS RESEARCH

This course comprises a total of fifteen Units distributed across three modules as follows:

Module 1 is composed of 5 Units

Module 2 is composed of 5 Units

Module 3 is composed of 5 Units

Module 1 guides you into the realm of Operations Research by explaining different approaches to Operations Research problems solving before delving fully into the concepts of Operations Research which is the primary concern of Unit 1. Unit 2 treats Modeling, while Unit 3, 4 and 5 take you through progressively advanced levels of Linear Programming.

In Module 2, Units 1 2 and 3 expound on Integer Programming, Dynamic Programming and Goal Programming respectively while Unit 4 revisits Transportation Model which you certainly must have encountered. This module is concluded with the Assignment Model and discusses amongst others the two methods of enumeration and reduced matrix which are very crucial in solving Assignment problems.

The final Module further exposes you to Inventory, Network Analysis, Sequencing, Line Waiting and Replacement. Take note that the topics in Module 3 particularly, and the problems solved as illustrative of the concepts introduced exposes you to a higher level of appreciation of the impact of, and the universality of Operation Research on our lives.

COURSE AIMS AND OBJECTIVES

The aim of CIT 656 is to further intimate you with Operations Research, acquaint you with the mathematical calculations and the practical approximations of the idealised theorems which lets you establish their practicable applications and indispensability in the real world always bearing in mind the practical limitations of the concepts idealised in the real world..

You in turn shall be required to conscientiously and diligently work through this course and upon completion of this course, you should be able to:

- Understand the meaning of Operations Research
- Highlight the historical development of Operations Research
- Describe the scientific nature of Operations Research
- Identify the importance and uses of Operations Research with respect to the various topics to be treated in the study
- State the limitations of Operations Research
- State the meaning of model in Operations Research
- Describe the various types of model
- Describe how to construct a model
- State some standard Operations Research model
- State the usefulness of linear programming in operations research
- State the properties of a linear programming model
- Identify some areas of application of linear programming
- Formulate a linear programming model
- State the usual assumptions of a linear programming model
- Solve a two-variable linear programming model graphically
- Preparation of LPD for use of simplex
- Understanding of the need of use of simplex

- Steps involved in using a simplex method.
- Preparing a simplex Table and understanding its various components.
- Demonstrating the use of simplex method for solving a LLP
- Solving LPP using maximization problem
- Understand optimal – dual concept
- Understand dual formulation procedure
- Interpret dual programming model
- Solve LP problems using duality
- Understand limitations of integer programming
- Identify the methods of integer programming
- Formulate integer programming model
- Solve IP problems using branch and bond method
- Understand the terminologies used in dynamic programming
- Identify the methods of dynamic programming
- Formulate dynamic programming model
- Solve dynamic programming problems using branch and bond method
- Understand the concept of goal programming
- Use multiple goals as goal programming problem
- Formulate goal programming model
- Solve goal programming problems graphically
- Understand limitations of integer programming
- Identify the methods of integer programming
- Formulate integer programming model

- Solve IP problems using branch and bound method
- Understand the concept of assignment model
- Solve assignment by enumeration method
- Solve assignment by Hungarian method
- Explain the concept of inventory
- Identify different types of inventory
- State the main reason for holding stock
- Define some important terminologies
- Identify the different EOQ model
- Determine the EOQ graphically and by use of model
- Differentiate the types of inventory control systems
- Critical Path Method (*CPM*)
- Programme Evaluation and Review Technique (*PERT*)
- Critical Path Planning (*CPP*)
- Critical Path Analysis (*CPA*)
- Critical Path Scheduling (*CPS*)
- Minimal Spanning Tree
- Shortest routes problems
- Describe the concept of sequencing
- State the assumptions made in the sequencing problem
- Define the terminologies used sequencing problem
- Do “Processing Job through different number of machine”

- Do “Processing of two job through m machines and n job through m machines
- Appreciate situations in which queuing problems are generated
- Learning to set objectives for the operation of queuing
- Understand standard queuing language and symbols.
- Understanding operating characteristics of queuing.
- Solving queuing problems in single-channel and multiple-channel situations
- Understand the advantages and limitations of queuing systems.
- Understanding that depreciable assets have to be replaced
- Formulation of assumption of Replacement Theory
- Understanding replacement policy for such items whose maintenances cost increases with time and also the money value changes with time (at constant rate)
- understand the mechanism of system failing suddenly
- Discuss group replacement policy

WORKING THROUGH THE COURSE

This course requires you to spend quality time to read. Whereas the content of this course is quite comprehensive, it is presented in clear language with lots of illustrations that you can easily relate to. The presentation style is qualitative and descriptive. This is deliberate and it is to ensure that your attention in the course content is sustained as a terser approach can easily “frighten” particularly when new concepts are being introduced.

You should take full advantage of the tutorial sessions because this is a veritable forum for you to “rub minds” with your peers – which provides you valuable feedback as you have the opportunity of comparing knowledge with your course mates.

COURSE MATERIAL

You will be provided course material prior to commencement of this course, which will comprise your Course Guide as well as your Study Units. You will receive a list of recommended textbooks which shall be an invaluable asset for your course material. These textbooks are however not compulsory.

STUDY UNITS

You will find listed below the study units which are contained in this course and you will observe that there are three modules. Each module comprises five Units each.

Module 1

- Unit 1 Concepts of Operations Research
- Unit 2 Modeling
- Unit 3 Linear Programming 1
- Unit 4 Linear Programming 2
- Unit 5 Linear Programming 3

Module 2

Unit 1	Integer Programming
Unit 2	Dynamic Programming
Unit 3	Goal Programming
Unit 4	Transportation
Unit 5	Assignment

Module 3 LINEAR INTEGRATED CIRCUITS

Unit 1	Inventory Model
Unit 2	Network Analysis
Unit 3	Sequencing Problem
Unit 4	Waiting Line
Unit 5	Replacement

TEXTBOOKS

There are more recent editions of some of the recommended textbooks and you are advised to consult the newer editions for your further reading.

Operations Research. By Prem Kumar Gupta and D.S. Hira

Operations Research. (Problem Solvers) By Research and Education Association.

Statistics and Operations Research. By Debashis Dutta

Operations Research By). O.T. Arowolo and G.O. Lawal

ASSESSMENT

Assessment of your performance is partly through Tutor Marked Assessment which you can refer to as TMA, and partly through the End of Course Examinations.

TUTOR MARKED ASSIGNMENT

This is basically Continuous Assessment which accounts for 30% of your total score. During this course you will be given 4 Tutor Marked Assignments and you must answer three of them to qualify to sit for the end of year examinations. Tutor Marked Assignments are provided by your Course Facilitator and you must return the answered Tutor Marked Assignments back to your Course Facilitator within the stipulated period.

END OF COURSE EXAMINATION

You must sit for the End of Course Examination which accounts for 70% of your score upon completion of this course. You will be notified in advance of the date, time and the venue for the examinations which may, or may not coincide with National Open University of Nigeria semester examination.

SUMMARY

Each of the three modules of this course has been designed to stimulate your interest in Operations Research and particularly its applications, while each Unit may be conceived as a conceptual building block in the study and practical application of Operations Research.

Module 1 commences with the Concepts of Operations Research and progresses through Modeling to Linear Programming which span the last three Units of this Module in advancing progression.

Module 2 treats three types of Programming; Integer Programming, Dynamic Programming and Goal Programming which serves as a foundation for the applications which are treated by this Module. These are the classical applications which are quite visible in daily life. The first being Transportation and the second Assignment and both of which essentially have optimisation as their goals

Module 3 continues where Module 2 stops and treats Inventory Model, Network Analysis, Sequencing Problem, Waiting Line and Replacement; all of which have significant practical application value.

It is essential to emphasise the need for you to take seriously the contents of the three Modules, particularly Modules 2 and 3 as you can and indeed will see them at work around you every day.

Needless to state that this course will change the way you see the world around you and my advice to you is that you make sure that you have enough referential and study material available and at your disposal, and you must devote sufficient **QUALITY TIME** to your studies.

I wish you the best of luck.

Course Code

CIT 656

Course Title	Operations Research
Writer Team	Arowolo O. School of Science and Technology Lagos State Polytechnics. Ikorodu.
Content Editor	Dr. Abiola B. School of Science and Technology National Open University of Nigeria



NATIONAL OPEN UNIVERSITY OF NIGERIA

UNIT 1 Concepts of Operations Research

CONTENTS

1.0	Introduction
2.0	Objective
3.0	Main Content
3.1	Definition of O.R
3.2	Historical Background of O.R
3.3	Basic facts about O.R as a concept
3.4	O.R. as an adaptation of the Scientific Approach
3.5	Role of O.R. in Business
3.6	Limitations of O.R.
4.0	Conclusion
5.0	Summary
6.0	Tutor Marked Assignment
7.0	References/Further Readings

1.0 INTRODUCTION

Operations Research has existed since the beginning of recorded history. As far back as World War II, operations research techniques have been developed to assist the Military during the war. Today, many organizations employ a staff of operation researcher or management science personnel or consultants to apply the principles of operations research to management problems.

There are actually several approaches in interpreting, analyzing and solving business problems; viz:

- i. The Conventional Approach: This involves following past techniques and solutions to solving present problems. This method if state; it offers little or nothing to the advancement in management.
- ii. The Observation Approach: A method of watching and learning from other managers in similar situation.
- iii. Systematic/Scientific Approach: Utilizes concept of theoretical systems, which may be some what different from the actual problem under study. This is the operations research method of solving management problem.

The successful use of operations research techniques usually results in a solution that is timely, accurate, flexible, economical, reliable and easy to understand and use. We will be familiar with the limitations, assumption and specific applicability of the techniques.

2.0 OBJECTIVES

By the end of this unit the reader will be able to:

- * Understand the meaning of Operations Research
- * Highlight the historical development of Operations Research
- * Describe the scientific nature of Operations Research
- * Identify the importance and uses of Operations Research with respect to the various topics to be treated in the study
- * State the limitations of Operations Research

3.0 MAIN TEXT

3.1 Definition

Defining Operations Research itself is very difficult. Like many other subjects that developed pragmatically and shade imperceptibly into adjoining subjects, it is more easily recognized than defined.

Generally speaking, operations research is an approach to the analysis of operations that to a greater or lesser extent adopts:

- i. Scientific method (observation, hypothesis, deduction and experimentation as far as possible).
- ii. The explicit formulation of complex relationships.
- iii. An inter-disciplinary nature.
- iv. A non-partisan attitude.

Operational Research can also be regarded as a scientific approach to the analysis and solution of management problem.

The council of the United Kingdom Operational Research Society defines Operational Research as “the attack of modern science on complex problems, arising in the direction and management of large systems of men, machines, materials and money in industry, business, government and defence. It goes on to state the distinctive approach as to develop a scientific model of the system; incorporating measurement of factors such as chance and risk, in order to predict and compare the outcomes of alternative decisions, strategies and controls. The purpose is to help management to determine its policy and action scientifically”.

It is also worth pointing out that an Operations Research project is often a team effort that involved people drawn from many different backgrounds including: Accountants, Engineers, Mathematicians, Statisticians and Scientist as well as the operations research experts themselves.

3.2 Historical Background of O.R

Pre-World war II: The roots of OR are as old as science and society. Though

the roots of OR extend to even early 1800s, it was in 1885 when Ferderick W. Taylor emphasized the application of scientific analysis to methods of production, that the real start took place.

Another man of early scientific management era was Henry L. Gantt. Most job-scheduling methods at that time were rather haphazard. A job, for instance, may be processed on a machine without trouble but then wait for days for acceptance by the next machine. Gantt mapped each job from machine to machine, minimizing every delay. Now with the Gantt procedure it is possible to plan machine loadings months in advance and still quote delivery dates accurately.

In 1917, A.K.Erlang, a Danish mathematician, published his work on the problem of congestion of telephone traffic. The difficulty was that during busy periods, telephone operators were made, resulting in delayed calls. A few years after years after its appearance, his work was accepted by the British Post Office as the basis for calculating circuit facilities.

The well known economic order quantity model is attributed to F.W. Harris, who published his work on the area of inventory control in 1915.

During the 1930s, H.C. Levinson, an American astronomer, applied scientific analysis to the problems of merchandising. His work included scientific study of customers' buying habits, response to advertising and relation of environment to the type of article sold.

However, it was the First Industrial Revolution which contributed mainly towards the development of OR. Before this revolution, most of the industries were small scale, employing only a handful of men. The advent of machine tools-the replacement of man by machine as a source of power and improved means of transportation and communication resulted in fast flourishing industry. It became increasingly difficult for a single man to perform all the managerial functions (of planning, sale, purchase, production, etc.). Consequently, a division of management function took place. Managers of production, marketing, finance, personnel, research and development etc., began to appear. With further industrial growth, further subdivisions of management functions took place. For example ,production department was sub-divided into sections like maintenance, quality control, procurement, production planning, etc.

World War II: During World War II, the military management in England called on a team of scientists to study the strategic and tactical problems of air and land defence. This team was under the direction of Professor P.M.S. Blackett of University of Manchester and a former naval officer. "Blackett circus", as the group was called,

included three physiologists, two mathematical physicists, one astrophysicist, one army officer, one surveyor, one general physicist and two mathematicians. Many of these problems were of the executive type. The objective was to find out the most effective allocation of limited military resources to the military operations and to the activities within each operation. The application included the effective use of newly invented radar, allocation of British Air Force Planes to missions and the determination of best patterns for searching submarines. This group of scientists formed the first OR team.

The name operations research (or operational research) was apparently coined because the team was carrying out research on (military) operation. the encouraging results of these effort led to the information of more such teams in British armed services and the use of scientific teams soon spread to western allies-the united states, Canada and France. thus through this science of operation research originated in England,the united states soon took the lead.in united state these OR teams helped in developing strategies from mining operations, inventing new flight patterns and planning of sea mines.

- (b) Post-world war II : immediately after the war,the success of military teams attracted the attention of industrial managers who were seeking solutions to their problems. Industrial operation research in U.K. and U.S.A. developed along different lines. In U.K., the critical economic situation required drastic increase in production efficiency and creation of new markets.nationalisation of a few key industries further increased the potential field for OR. Consequently OR soon spread from military to government, industrial, social and economic planning.

In U.S.A.the situation was different. Impressed by its dramatic success in U.K., defence operations research in U.S.A was increased. Most of the war experienced OR workers remained in military service. Industrial executives did not call for much help because they were returning to the peace-time situation and many of them believed that it was merely a new application of an old technique. Operation research by a variety of names in that country such as operational analysis, operation evaluation, systems analysis, system evaluation, system research and management science.

The progress of industrial operational research in U.S.A. was due to advent of second industrial revolution which resulted in *automation*-the replacement of man by machine as a *source of control*.the new revolution began around 1940s when electronic computers became commercially available. The electronic brains processed tremendous computational speed and information storage. But for these digital computers, operation research with its complex computational problems could not have achieved its promising place in all kinds of operational environments.

In 1950, OR was introduced as a subject for academic study in American universities since then this subject has been gaining ever increasing importance for the students of Mathematics, Statistics, Commerce, Economics, Management and Engineering. To increase the impact of operation research, the Operations Research Society of America was formed in 1950. In 1953, the Institute of Management Sciences (IMS) was established. Other countries followed suit and in 1959 International Federation of OR began to appear. Some of them (in English) are:

- *Operations Research
- *Opsearch
- *Operational Research Quarterly
- *Management Science
- *Transportation Science
- * Mathematics of Operations Research
- * International Journal of Game Theory, etc.

Today, the impact of operations research can be felt in many areas. This is shown by the ever increasing number of educational institutions offering this subject at degree level. Of late, OR activities have spread to diverse fields such as hospitals, libraries, Planning, transportation systems, management, defence, etc.

3.3 Basic facts about O.R as a concept

The following are basic facts about Operations Research:

- It is a science-based approach to analyzing problems and decision situations to aid solving such problems and decision-making. It is therefore a practical activity, although based on the theoretical construction and analysis.
- It is an approach and an aid to problem-solving and decision-making.
- Its distinctive approach is facts-finding and modeling.
- It examines functional relations (i.e. functions of a system and their related components) from a system overview.
- It utilizes interdisciplinary mixed-team approach to solving management problems.
- It adopts the planned approach (updated scientific method which reflects technological advancement as the computer) to management problems.
- It helps to discover new problems as one problem is being solved.

3.4. O.R. as an adaptation of the Scientific Approach

Operations Research is most fundamentally science-based. It is so by adoption and adapting the scientific approach in analyzing operational decision problems. (These are problems involved in carrying out operations). The way operations research is the adoption and adaptation of the scientific approach is as follows:

i. Definition of Problem

This involves the development of a clear and concise statement of the problem at hand. This gives direction and meaning to other steps.

In defining the problem, it is important that the whole system be examined critically in order to recognize all the areas that could be affected by any decision taking. It is essential to examine the symptoms and true causes of the problem when defining the issue.

Note that when the problem is difficult to qualify, it may be necessary to develop specific and measurable objectives that may not solve the real problem.

ii. Construction of a Model

This step involves the construction of a suitable model (usually mathematical), which is a representation of the problem at hand.

It might be of a functional nature as in linear programming or have a logical structure as in simulation and algorithms.

E.g. Minimize: $C = 4x + 5y$

Subject to: $x + 3y \geq 6$

$x + y \geq 3$

$x, y \geq 0$, which is a linear programming model.

iii. Data Collection

It involves obtaining quantitative data either from existing records or a new survey that fits well into the constructed model of the problem.

iv. Developing a Solution

This involves the manipulation of the model to arrive at the best (optimal) solution to the problem. It may require solving some mathematical equations for optimal decisions as in calculus or linear programming models. It may also be a logical approach or a functional approach which does not require solving a mathematical equation, such as in queuing theory. The optimal solution is then determined by some criteria.

v. Testing the Model and its Solution

This involves determining the accuracy or the completeness of the data used in the model because inaccurate data leads to inaccurate solutions. If the model can adequately predict the effect of the changes in the system, however simple it may be, it is acceptable.

vi. Interpretation of the Results/Establishment of Controls

This involves determining the implication of the solutions to the system. In most cases, a solution to a problem will result in a kind of action or change in the organization. The implication of these actions or changes must be determined and analyzed before results are implemented. This analysis (sensitivity analysis) determines how much the solution changes if there were changes in model or in the input data. Controls are therefore established so that changes that make a significant difference in solution are recognized and taken into account.

vii. Implementation of Model

This is the process of incorporating the solution into the system, which is carried out by the personnel already working in the area and not the Operations Research team.

The solution to the problem has to be translated to a set of operating instructions which can be handled by the personnel involved.

Flow Chart Showing the Stages in Operations Research

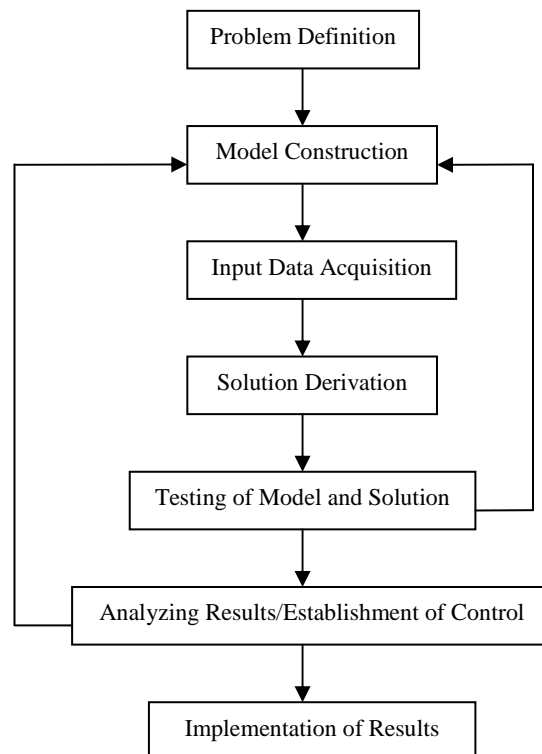

3.5 Role of Operations Research in Business

Operations Research help to determines the information requirements that enable the best decisions to be made, subject to cost constraints and to formulation of rules or procedures for making these operating decisions. It is also concern with improving the day-to-day efficiency of a company's operation.

Business areas where Operations Research is applicable includes:

- i. Stock re-ordering policies.
- ii. Transport schedules.
- iii. Product mix.
- iv. Production flows.
- v. Allocation problems i.e. which jobs should be allocated to which machines.

- vi. Time wasted queuing at issuing, counters.
- vii. Scheduling of activities in a complex project.
- viii. General congestion problem.

3.6 Limitations of Operations Research

- i. It is often difficult to balance the requirement of reality and those of simplicity.
- ii. The quality of data collection may be poor and/or inaccurate.
- iii. In many cases, the solution of Operations Research problem is restricted by the lack of suitable solution techniques.
- iv. The derived solution may be sub-optimal i.e. the boundaries of the problem may be open.
- v. An Operations Research model is static but the solution it imitates is dynamics.
- vi. Conflict between conclusion reached by the Operations Research analyst and the opinion of time managers as to the best course of action.

3.7 Use of Computer

The computer as we all know is the major modern in information technology equipment. One of its uses, which most people in our part of the world are not yet attuned to, is problem-solving. Operations research uses the computer in this regard.

The following process is useful in this regard.

- i. Identifying situation e.g. production planning.
- ii. A number of activities to be performed e.g. tables, chairs, doors to be made. Generalizing term is j , the variable representing the magnitude of j th activity is X_j .
- iii. A number of resources with general term i and available quantity b_i .
- iv. Profit yield per unit of j th activity - C_j .
- v. Amount of i th resource required by 1 unit of j th activity - a_{ij} .
- vi. Obtain the model:

The logic of the situation can be studied to achieve the famous linear programming model:

$$\text{Maximize: } Z = \sum C_j X_j$$

$$\text{Subject to: } \sum a_{ij} X_j \leq b_i, v_i$$

$$X_j \geq 0.$$

- vii. Solve the model by using the computer that has software for solving linear programming model of our size. The computer, after keying the data will give the solution.

EXAMPLE (A Break Even Model)

The sales manager of Turnover Limited maintains he could increase the sales turnover (in units) of any of the company's product by 50 percent if he was authorized to give a 10% price discount and place appropriate additional advertising matter. The Board wish to know the maximum additional advertising expense they can incur in respect of any given product without the manager's proposal resulting in a smaller profit.

SOLUTION

This situation can be modeled as follows:

Let p be the current production selling price, m be the product marginal cost and, q be the current turnover (in units).

The current product contribution is:

$$q(p - m) \text{ and}$$

the new product contribution net of the additional advertising is:
 $1.5q(0.9p - m) - \text{cost of additional advertising.}$

Since at the worst, these two contributions must equal each other to make proposal viable, then:

$$q(p - m) = 1.5q(0.9p - m) - \text{cost of additional advertising.}$$

Cost of additional advertising is:

$$\begin{aligned} 1.5q(0.9p - m) - q(p - m) &= 1.35qp - 1.5qm - qp + qm \\ &= q(0.35p - 0.5m). \end{aligned}$$

Since we can put this expression in a more useful form by taking $1/2$ out of the brackets, we have:

Maximum additional advertising cost to be:

$$\frac{n}{2}(0.7 \times 10 - 4).$$

The Board now have a useful model, for if one of their products has a marginal cost #4 and sells 10,000 units at #10, then:

Maximum additional product advertising cost is:

$$\frac{10,000}{2}(0.7 \times 10 - 4) = \$15,000.$$

The model, however, goes further than this, for it also tells the Board that any product with a marginal cost of 70% or more of the selling price must never be subjected to the sales manager's proposal. This follows from the fact that if $M > 0.7p$, a negative result i.e. the additional advertising would need to be negative. It would, then, be impossible to allow the manager any additional advertising expenditure.

4.0 CONCLUSION

This unit introduce you to the formal study of Operations Research. However , what has been discussed is not exhaustive. Further reading is hereby recommended.

5.0 SUMMARY

- Operations Research is scientific in nature and is closely related to management science.
- Operations Research has some limitations
- Effective use of Operations Research involves people working as team to solve identified problems

6.0 TUTOR MARKED ASSIGNMENT

- (1). Explain the term Operations Research
- (2). Describe the role, methodology and limitations of Operations Research

7.0 REFRENCES/FURTHER READING

1. Operations Research. By Prem Kumar Gupta and D.S. Hira
2. Operations Research. (Problem Solvers) By Research and Education Association.
3. Statistics and Operations Research. By Debashis Dutta
4. Operations Research By). O.T. Arowolo and G.O. Lawal

UNIT 2 Modeling in Operations Research

CONTENTS

- 1.0** Introduction
- 2.0** Objectives
- 3.0** Main Text
 - 3.1** Types of Models
 - 3.2** Types of Mathematical Model
 - 3.3** Structure of O.R. mathematical Model
 - 3.4** How to construct a model
 - 3.5** Standard O.R. model
- 4.0** Conclusion
- 5.0** Summary
- 6.0** Tutor Marked Assignment
- 7.0** References/ Further Readings

1.0 INTRODUCTION

Modeling is fundamental to the Operations Research approach. It is a way of representing the behaviour of a situation to enable us deduce what is best to do about the system. Models are therefore tools for representing a situation to understand it and for reasoning about it.

If for instance, the relationship between the demand for an item and time is found to be represent able by a seasonal pattern, then we can use the representation to identify when it is best for us to trade in the item. This is the kind of thing operations research disciplines us to do as an objective and rational way of tackling situations.

The model we build must be based on the facts of the situation being modeled, only being represented in a convenient way either for better comprehension or for reasoning with or to communicate with. The facts are usually in terms of:

- i. What the under acting entities are e.g. item and time in the above example.
- ii. How the entity interrelate e.g. seasonal relationship between the item and time in the above example, in which relationship we call time series.

A major merit in modelling is that knowledge gain about a model framework can be used in understand, communicating, and/or reasoning about other situation that can be modelled using the same framework. Hence, for instance knowledge generally gain about network model framework is adaptable for me in studying and analyzing projects, decision networks, road network, etc. This approach is a generalizing one and therefore, it is efficient.

2.0. OBJECTIVES

At the end of this unit you will be able to :

- State the meaning of model in Operations Research
- Describe the various types of model
- Describe how to construct a model
- State some standard Operations Research model

3.0 . MAIN TEXT

3.1 Types of Models

1. Symbolic or Mathematical Model

This is the most important type of model. Mathematical modeling focuses on creating a mathematical representation of management problems in organizations. All the variables in a particular problem are expressed mathematically. The model then provides different outcomes, which will result from the different choices the management wishes to use. The best outcome in a particular situation will help the management in decision-making. These models use set of mathematical symbols and hence are also called symbolic models.

The variables in many business and industry situations can be related together by mathematical equations. To understand the concepts of symbolic or mathematical model, visualize a balance sheet or profit and loss account as a symbolic representation of the budget. Similarly, the demand curve in economics can be seen as symbolic representation of the buyers' behaviour at varying price levels.

2. Simulation Models

In Simulation model, the behaviour of the system under study is 'initiated' over a period of time'. Simulation models do not need mathematical variables to be related in the form of equations, normally, these models are used for solving such problems that cannot be solved mathematically. Simulation is a general technique, which helps us in developing dynamic models, which are similar to the real process. Developing

good simulation models is difficult because 'creating' a real life situation to perfection is extremely difficult.

3. Iconic Models

These models represent the physical simulations to the real life system under. Physical dimensions are scaled up or down to simplify the actual characteristic and specifications of the system. Preparation of prototype models for say an automobile or 3-D plant layout are some examples of iconic models.

4. Analog Model

They are not the exact replica. Like the iconic models these are smaller, simple physical system as compared to the real life system which are complex. These models are used to explain an actual system by analog.

5. Deterministic Model

When the change of one variable has a certain or define change in the outcome, the model is called a deterministic model. Infact, everything is absolutely clearly defined and the results are known. Economic Order Quantity (EOQ) is a deterministic model, as economic lot size can be exactly known, with change in one of the variables in the EOQ formula.

3.2 Types of Mathematical Models

Mathematical models can be classified in several ways. These include the following:

Probabilistic versus Deterministic

Models that incorporate uncertainty in terms of probabilities of future event occurring are probabilistic ones, while those that assume certain knowledge of such events are deterministic ones.

Deterministic models predict the exact outcome of a situation because it is based on certain known laws.

Probabilistic models deals with situation that are random in character and can predict the outcome within a certain stated or known degree of accuracy.

For example, in a project management situation, the critical path method (*CPM*) uses a deterministic network model in which the durations of the activities are assumed to be known for certain. Whereas, the program evaluation and review technique (*PERT*) uses a model that incorporates some probability distribution of the durations.

Qualitative Versus Quantitative

Mathematical models are essentially symbolic and structural. Where the entities involved are kinds of things or attributes rather than the quantities in which they exist, then we have a qualitative model.

Quantitative models, on the other hand involve quantities of attributes as the interacting entities.

Qualitative (or conceptual) models are often starting points in formulating quantitative models. Inventory and linear programming mathematical models involve such qualitative frameworks as starting points.

Linear versus Non-linear

A mathematical model is normally put in the form of relationships between the quantitative variables. The relationships could be linear or non-linear. They are linear when changes in the independent or input variables result in constant proportional changes in the dependent, or output variables.

The graphs of such relationships are in the form of straight lines. The linearity property is one of constant return to scale.

Examples of linear relationship are:

$$y = 4x + 2$$

$$y = 5 + 5w + 3x$$

While examples of non-linear relationships are:

$$y = 6 + 5x + x^2$$

$$y = xz^2 + 3x^2 + 5z + 2$$

Static versus Dynamic

Models that assume that the situation being represented will not change, at least in its essential features, within the operational period, are static ones. While those that incorporate changes are dynamic ones. In this respect, linear programming models that use only one set of values of the input variables are static, while dynamic programming that use only one set of values of the input variables that change over time are dynamic.

Standard versus Custom-made Models

Standard models are format for representing recurring features and relationships. They are usually put in generalized forms. They are used in appropriate specific situations by replacing the features in the models with the corresponding features in the real, particular situation. There are several such models that are in use in operations research. Linear programming models are an example of standard models.

Custom-made models, on the other hand are obtained specially for specific situations. This has to be done when no standard model framework exists, or is known to be reasonably appropriate for the specific situation. We refer to such modelling as being from fundamentals.

Analytic versus Simulation

An analytic model is one that represents the relationship between the variables in the form of formulas. Linear programming model is an example.

A simulation model, on the other hand, describes the process involved in a simulation, indicating the mathematical relationships that exist at each stage.

In this sense, simulation is an imitation of the step-by-step process involved in the build-up of system relationships. We shall return to the subject of simulation later.

3.3 Structure of Operations Research Mathematical Models

Operations Research Mathematical Models are decision problem models in the following general form:

Entity	Representation
Objective	E
Factors:	
1. Controllable (or decision) variables	X_i
2. Uncontrollable variables	Y_i
Structure	$E = f(X_i, Y_i)$

Each model will have entities in them that are in the foregoing categories.

In a simple inventory situation for example, the interacting entities are the following:

Entity	Symbol
Total cost	TC
Order quantity	Q
Purchase cost	C_p
Ordering cost	C_o
Holding cost	C_h
Demand	D

The conceptual model can then be put into symbolic (mathematical) form as follows:

$$TC = DC_p + \frac{D}{q}C_o + qC_pC_h.$$

Thus, we see that

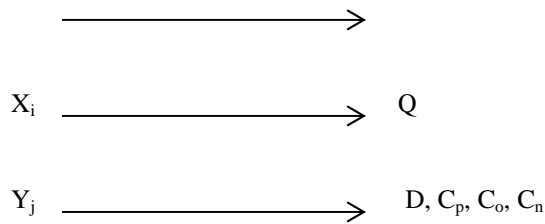

Solving a mathematical model involves deducing what values of the decision (controllable) variables will yield best result.

We can apply appropriate pure mathematics method to make such deductions. In the case of the simple inventory model, the method of calculus is used in solving optimization problem involved to yield the famous Economic Order Quantity (*EOQ*) formula:

$$Q = \sqrt{\frac{2DC_o}{C_p C_h}}$$

3.4 How to Construct a Model

To construct a model. You need to observe real-word problem and make assumptions about influencing factors. This is called abstraction.



You must know enough about the mechanics of mathematics to derive results from model.

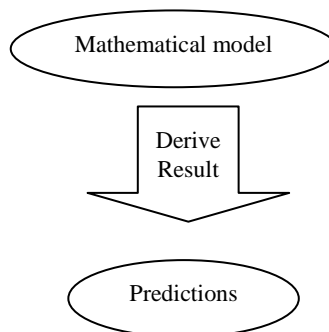

The next step is to gather data. Does the prediction given by the model fit all the known data? If not, you will use the data to modify the assumptions used to create the model. This is an ongoing process.

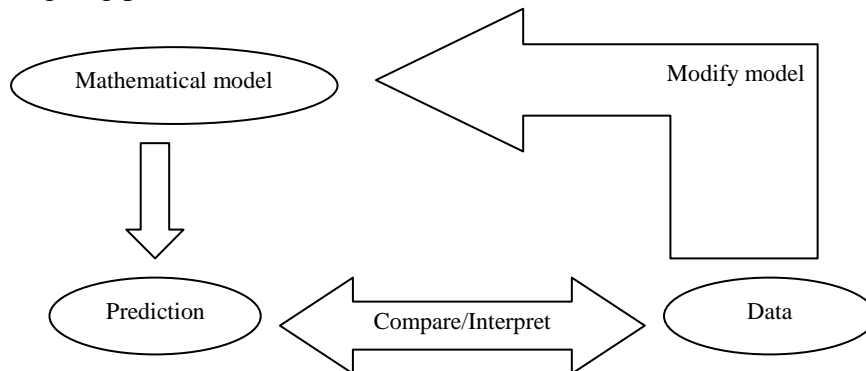

3.5 Standard Operations Research Models

Operations Research practice over the years has led to the identification of problems that recur in diverse situations. Ways of representing (modelling) them have been developed and techniques for solving them also developed. These problem types are called prototypes. While models for representing them bear specific names and so also are the techniques for solving them. The table below summarizes the common prototypes, their nature, model and techniques for handling them.

Major prototypes and common techniques available for solving them.

Prototype	Nature	Common Solution Technique
Allocation and its extensions e.g. Transportation	How best to allocate limited resources to activities	<ol style="list-style-type: none"> 1. Mathematical programming e.g. Linear programming, integer programming, goal programming. 2. Specific techniques e.g. Transportation Techniques, Assignment Techniques.
Inventory	Determining optimal order quantity in a situation requiring purchase to store pending usage	<ol style="list-style-type: none"> 1. Inventory theory techniques e.g. the (<i>EOQ</i>) method. 2. Simulation.
Waiting lines	What best level of facilities will minimize cost of queues, or what order of service will do so	<ol style="list-style-type: none"> 1. Queuing theory 2. Simulation
Coordination and Extension	How best to manage pre-set sequencing of jobs or activities e.g. comprising a projector an assembly line	<ol style="list-style-type: none"> 1. Network techniques e.g. <i>CPM</i> and <i>PERT</i>. 2. Line balancing techniques.
Replacement; including general maintenance	Maintenance of operating units through replacement and/or servicing	<ol style="list-style-type: none"> 1. Replacement techniques 2. Maintenance techniques 3. Simulation 4. Manpower management models
Competition	What strategy is best to adopt in a conflict e.g. competitive situation	<ol style="list-style-type: none"> 1. Game theory 2. Hyper games 3. Meta games

4.0. CONCLUSION

As in the summary.

5.0. SUMMARY

- * Models help to simplify complex situation for ease of understanding and evolving solution to problems.
- * The component of an operations research model are variable and Parameter.
- * Mathematical Model are the widely use operations research model

6.0. TUTOR MARKED ASSIGNMENT

- 1.(a) Explain the term models in operations research
(b) Enumerate the types of models used in operations research.
2. In a particular one product company, it has been noted that the value of sales per day is given by the expression :
 $\{ \#1000 - \text{selling price per unit} \}$ If daily fixed cost amount to $\#1000$ and the variable cost per unit is $\#2$, then, prepare a profit model

7.0. References/ Further Readings

1. Operations Research. By Prem Kumar Gupta and D.S. Hira
2. Operations Research. (Problem Solvers) By Research and Education Association.
5. Statistics and Operations Research. By Debashis Dutta
6. Operations Research By). O.T. Arowolo and G.O. Lawal

UNIT 3 LINEAR PROGRAMMING (LP) 1

1.0 Introduction

2.0 Objective

3.0 Main Content

3.1 Application of LP to Business

3.2 Properties of LP Model

3.3 Assumption of LP

3.4 Formulation of LP Model

3.5 Examples on Formulation of LP Model

3.6 Graphical Solution of Linear Programming Problems

3.7 Linear Programming Theorem

4.0 Conclusion

5.0 Summary

6.0 Tutor Marked Assignment

7.0 Reference/ Further Readings

1.0. INTRODUCTION

Many management decisions involve trying to make the most effective use of organization resources. These resources include Machinery, Labours, Money, Time, Warehouse space or Raw materials to produce goods (machinery, furniture, food or cooking) or service (schedules for machinery and production advertising policies or investment decision).

Linear Programming (LP) is a widely used mathematical techniques designed to help managers in planning and decision making relative to resource allocations.

2.0. OBJECTIVE

By the end of this unit you should be able to :

- State the usefulness of linear programming in operations research
- State the properties of a linear programming model

- Identify some areas of application of linear programming
- Formulate a linear programming model
- State the usual assumptions of a linear programming model
- Solve a two-variable linear programming model graphically

3.0. MAIN TEXT

3.1. Application of Linear Programming to Business

i. Product-Mix

Use in the selection of the product-mix in a factory to make best use of machine and machine hours available while maximizing profit, that is, to find out which product to include in production plan and in what quantities that should be produced.

ii. Blending Problems

Use for the selection of different blends of raw materials to produce the best combinations at minimum cost e.g. food drinks, etc.

iii. Production Scheduled

Use to develop a production scheduled that will satisfy future demands for a firm's product and at the same time minimize production and inventory cost.

iv. Production Quantity

Use in determination of how much quantity to produce of different grades of petroleum product (say) to yield maximum profit.

v. Distribution System

Use in determining a distribution system that will minimize total shipping cost from several warehouses to various market locations.

vi. Limited Advertisement

Use in the allocation of limited advertising budget among radio, TV and newspaper spots in order to maximize the returns on investment.

vii. Investment

Use in selecting investment port-folio from a variety of stocks and bonds available in such a way as to maximize the returns on investment.

viii. Work Scheduled

Use in the development of a work scheduled that allows a large restaurant to meet staff needs at all hours of the day, while minimizing the total number of employees.

3.2 Properties of Linear Programming Model

All linear programming models have four basic properties in common. They are:

- i. All LP models seek to maximize or minimize some quantity, usually profit or costs.
- ii. All LP models have constraints or limitations that limit the degree to which the objective can be pursued. E.g. deciding how many units of product in a product line to be produced is restricted to the manpower and machinery available.
- iii. There must be alternative course of action to choose from e.g. if there are 4 different products, management may decide (using LP) how to allocate limited resources among them.
- iv. Objectives and constraints in LP model must be expressed in linear equations and inequalities.

3.3 Assumption of Linear Programming

- i. **Certainty**
We assume that numbers in the objective and constraints are known with certainty and do not change during the period being studied.

- ii. Proportionality
We are sure that proportionality exists in the objective and the constraints. This means that, if production of one unit of product uses two of a particular scarce resource; then making five units of that product uses ten resources.
- iii. Additivity
This means that the total of all activities equals the sum of each individual activity.
- iv. Divisibility
This means that solution may take fractional values and need not be in whole numbers (integers). If a fraction of a product cannot be produced, integer programming problem exist.
- v. Non-negativity
We assume that all answers or variables are non-negative. Negative values of physical quantities are an impossible solution.

3.4 Formulation of Linear Programming Model

Linear programming problems are optimization problem which are stated verbally or in words. The following steps can be used to formulate the model of any optimization problem.

Step 1

Choose variables and notations that will be used to form the objective and constraints functions.

Step 2

Identify the objective function to either maximize or minimize e.g. maximizes profit or minimizes cost.

Step 3

Develop mathematical relationships to describe objective and constraints.

3.5 Examples on Formulation Linear Programming Models

EXAMPLE 1 (Allocation of Resources in Production)

A farmer has 100 acres on which to plant two crops: corn or wheat. To produce these crops, there are certain expenses as shown in the table.

Item	Cost per Acre (#)
Corn	
Seed	12
Fertilizer	58
Planting/care/harvesting	50
Total	120
Wheat	
Seed	40
Fertilizer	80
Planting/care/harvesting	90
Total	210

After the harvest, the farmer must store the crops awaiting proper market conditions. Each acre yields an average of 110 bushels of corn or 30 bushels of wheat. The limitations of resources are as follows:

Available capital: #15,000.

Available storage facilities: 4,000 bushels.

If net profit (the profit after all expenses have been subtracted) per bushel of corn is \$1.30 and for wheat is \$2.00, how should the farmer plant the 100 acres to maximize the profits?

SOLUTION

To formulate a mathematical model, begin by letting:

x = Number of acres to be planted in corn.

y = Number of acres to be planted in wheat.

There are certain limitations or constraints.

- The number of acres planted cannot be negative, so
 $x \geq 0$
 $y \geq 0$

- The amount of available land is 100 acres:

$$x + y \leq 100.$$

Why not $x + y = 100$? it might be more profitable for the farmer to leave some land out of production i.e. it is not necessary to plant all the land.

- We also know that:

Expenses for planting the corn = $120x$.

Expenses for planting the wheat = $210y$.

The total expenses cannot exceed \$15,000:

This is the available capital:

$$120x + 210y \leq 15000$$

- The yields are::

Yield of acreage planted in corn = $110x$.

Yield of acreage planted wheat = $30y$.

The total yield cannot exceed the storage capacity of 4,000 bushels:

$$110x + 30y \leq 4000.$$

Summary of constraints:

$$x + y \leq 100$$

[Available land]

$$120x + 210y \leq 15000$$

[Available capital]

$$110x + 30y \leq 4000$$

[Storage capacity]

$$x \geq 0$$

[Non-negativity]

$$y \geq 0$$

[Non-negativity]

- Now, let P represent total profit. The farmer wants to maximize the profit, P.

$$\begin{aligned} \text{Profit from corn} &= \text{value} \cdot \text{amount} \\ &= 1.30 \cdot 110x \\ &= 143x. \end{aligned}$$

$$\begin{aligned} \text{Profit from wheat} &= \text{value} \cdot \text{amount} \\ &= 2.00 \cdot 30y \\ &= 60y. \end{aligned}$$

$$P = \text{profit from corn} + \text{profit from wheat} = 143x + 60y.$$

The linear programming model is stated as follows:

$$\text{Maximize: } P = 143x + 60y \quad [\text{Available land}]$$

Subject to:

$$x + y \leq 100 \quad [\text{Available land}]$$

$$120x + 210y \leq 15000 \quad [\text{Available capital}]$$

$$110x + 30y \leq 4000 \quad [\text{Storage capacity}]$$

$$x \geq 0 \quad [\text{Non-negativity}]$$

$$y \geq 0 \quad [\text{Non-negativity}]$$

EXAMPLE 2 (Allocation of Resources in Manufacturing)

ONIJOGBO manufactures two types of settee; half-upholstered and full-upholstered. The contribution per unit to profit is #80 for half-upholstered and #90 for full-upholstered. The amount of materials needed per product and maximum available materials are given below:

Product	Unit of Material		
	Wood	Foam	Cover
Half-upholstered	2	2	5
Full-upholstered	1	4	5
Maximum available	12	24	35

Required: formulate the linear programming model for the above problem.

SOLUTION

We want to maximize the profit, P. There are two types of items, half-upholstered and full-upholstered.

Let, x = Number of half-upholstered produced.

y = Number of full-upholstered produced.

Then,

Profit from half-upholstered = $\$80x$.

Profit from full-upholstered = $\$90y$.

P = profit from half-upholstered + profit from full-upholstered

$$P = \$80x + \$90y .$$

The constraints are:

i. Non-negativity

$$x \geq 0$$

$$y \geq 0$$

The number of product must be non-negative.

ii. Wood Material

$2x$ = Amount of wood material used for half-upholstered.

y = Amount of wood material used for full-upholstered.

The total wood material cannot exceed 12 :

This is the maximum available: $2x + y \leq 12$.

iii. Foam Material

$2x$ = Amount of foam material used for half-upholstered.

$4y$ = Amount of foam material used for full-upholstered.

The total foam material cannot exceed 24 :

This is the maximum available: $2x + 4y \leq 24$.

iv. Cover Material

$5x$ = Amount of cover material used for half-upholstered.

$5y$ = Amount of cover material used for full-upholstered.

The total cover material cannot exceed 35 :

This is the maximum available: $5x + 5y \leq 35$.

Thus, the linear programming model is:

Maximize: $P = \$80x + \$90y$.

Subject to:

$$2x + y \leq 12$$

[Wood material]

$$2x + 4y \leq 24$$

[Foam material]

$$5x + 5y \leq 35$$

[Cover material]

$$x \geq 0$$

$$y \geq 0$$

[Non-negativity]

[Non-negativity]

EXAMPLE 3 (Diet Problem)

A convalescent hospital wishes to provide at a minimum cost, a diet that has a minimum of 200g of carbohydrates, 100g of protein and 120g of fats per day. These requirements can be met with two foods:

Food	Carbohydrates	Protein	Fats
A	10g	2g	3g
B	5g	5g	4g

If food A cost $29k$ per ounce and food B cost $15k$ per ounce, how many ounces of each food should be purchased for each patient per day in order to meet the minimum requirements at the lowest cost? Required: formulate the LP model.

SOLUTION

Let, x = Number of ounces of food A.

y = Number of ounces of food B.

The minimum cost, C , is found by:

Cost of food A = $.29x$.

Cost of food B = $.15y$.

$$\therefore C = .29x + .15y$$

The constraints are:

$$x \geq 0$$

$$y \geq 0$$

The amounts of food must be non-negative.

The table gives a summary of nutrients provided:

Food	Amount (in Ounces)	Total Consumption (in Grams)		
		Carbohydrates	Protein	Fats
A	x	$10x$	$2x$	$3x$
B	y	$5y$	$5y$	$4y$
Total		$10x + 5y$	$2x + 5y$	$3x + 4y$

Daily requirements:

$$10x + 5y \geq 200$$

$$2x + 5y \geq 100$$

$$3x + 4y \geq 120$$

The LP model is:

$$\text{Minimize: } C = .29x + .15y$$

Subject to:

$$10x + 5y \geq 200 \quad [\text{Carbohydrates}]$$

$$2x + 5y \geq 100 \quad [\text{Protein}]$$

$$3x + 4y \geq 120 \quad [\text{Fats}]$$

$$x \geq 0 \quad [\text{Non-negativity}]$$

$$y \geq 0 \quad [\text{Non-negativity}]$$

EXAMPLE 4 (Investment Problem)

Big Bros. Inc. is an investment company doing an analysis of the pension fund for a certain company. A maximum of \$10 million is available to invest in two places. No more than \$8 million can be invested in stocks yielding 12% and at least \$2 million can be invested in long-term bonds yielding 8%. The stock-to-bond investment ratio cannot be more than 1 to 3. How should Big Bros. advise their client so that the pension fund will receive the maximum yearly return on investment?

Required: formulate the LP model.

SOLUTION

To build this model, you need the simple interest formula:

$$I = prt; \text{ where,}$$

I = Interest: The amount paid for the use of another's money.

p = Principal: The amount invested.

r = Interest rate: Write this as a decimal. It is assumed to be an annual interest rate, unless otherwise stated.

t = Time: In years, unless otherwise stated.

Let, x = Amount invested in stocks [12% yield]

y = Amount invested in bonds [8% yield]

Stocks: $I = .12x$, $p = x$, $r = .12$ and $t = 1$

Bonds: $I = .08y$, $p = y$, $r = .08$ and $t = 1$

Return on investment, R , is found by:

$$R = .12x + .08y.$$

Constraints:

- $x \geq 0$ [Investments are non-negativity]
- $y \geq 0$ [Investments are non-negativity]
- $x + y \leq 10$ [Maximum investment]
- $x \leq 8$ [Not more than #8 million in stocks]
- $y \geq 2$ [Not less than #2 million in bonds]
- $3x \leq y$ [Stock to bond ratio of 1 to 3 i.e. must invest #3 million in bonds for every #1 million invested in stocks].

Thus, the LP model for this problem is::

Maximize: $R = .12x + .08y$

Subject to:

- $x + y \leq 10$
- $x \leq 8$
- $y \geq 2$
- $3x - y \leq 0$
- $x \geq 0$
- $y \geq 0$

EXAMPLE 5 (Transportation Problem)

TRAX Ships a certain refrigerator unit from factories in Lagos and Onitsha to distribution centers in Abuja and Kano. Shipping costs are summarized in the table below:

Source	Destination	Shipping cost
Lagos	Abuja	#30
	Kano	#40
Onitsha	Abuja	#60
	Kano	#50

The supply and demand, in number of units, is shown below:

Supply	Demand
Lagos, 200	Abuja, 300
Onitsha, 600	Kano, 400

How should shipments be made from Lagos and Onitsha to minimize the shipping cost?

SOLUTION

The information of this problem can be summarized by the following “map”.

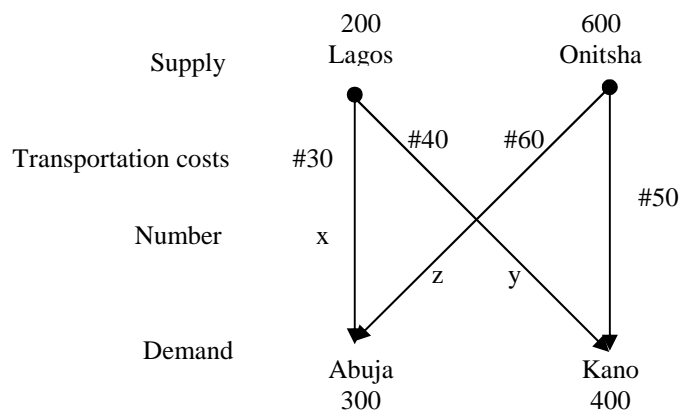

Suppose the following number of units is shipped.

Source	Destination	Number	Shipping cost
Lagos	Abuja	x	$30x$
	Kano	y	$40y$
Onitsha	Abuja	z	$60z$
	Kano	w	$50w$

The LP model is as follows:

Minimize: $C = 30x + 40y + 60z + 50w$

Subject to:

- $x + y \leq 200$ [Supply]
- $z + w \leq 600$ [Supply]
- $x + z \geq 300$ [Demand]
- $y + w \geq 400$ [Demand]
- $x \geq 0, y \geq 0, z \geq 0, w \geq 0$ [Non-negativity]

3.6 Graphical Solution of Linear Programming Problems

In the previous section, we looked at some models called linear programming models. In each case, the model had a function called an objective function, which was to be maximized or minimized while satisfying several conditions or constraints. If there are only two variables, we will use a graphical method of solution. We begin with the set of constraints and consider them as a system of inequalities. The solution of this system of inequalities is a set of points, S . Each point of the set S is called a feasible solution. The objective function can be evaluated for different feasible solutions and the maximum or minimum values obtained.

EXAMPLE 6

Maximize: $R = 4x + 5y$

Subject to:

$$2x + 5y \leq 25$$

$$6x + 5y \leq 45$$

$$x \geq 0, y \geq 0$$

SOLUTION

To solve the above linear programming model using the graphical method, we shall turn each constraints inequality to equation and set each variable equal to zero (0) to obtain two (2) coordinate points for each equation (i.e. using double intercept form).

Having obtained all the coordinate points, we shall determine the range of our variables which enables us to know the appropriate scale to use for our graph. Thereafter, we shall draw the graph and join all the coordinate points with required straight line.

$$2x + 5y = 25 \text{ [Constraint 1]}$$

When $x = 0$, $y = 5$ and when $y = 0$, $x = 12.5$.

$$6x + 5y = 45 \text{ [Constraint 2]}$$

When $x = 0$, $y = 9$ and when $y = 0$, $x = 7.5$.

Minimum value of x is $x = 0$.

Maximum value of x is $x = 12.5$.

Range of x is $0 \leq x \leq 12.5$.

Minimum value of y is $y = 0$.

Maximum value of y is $y = 9$.

Range of y is $0 \leq y \leq 9$.

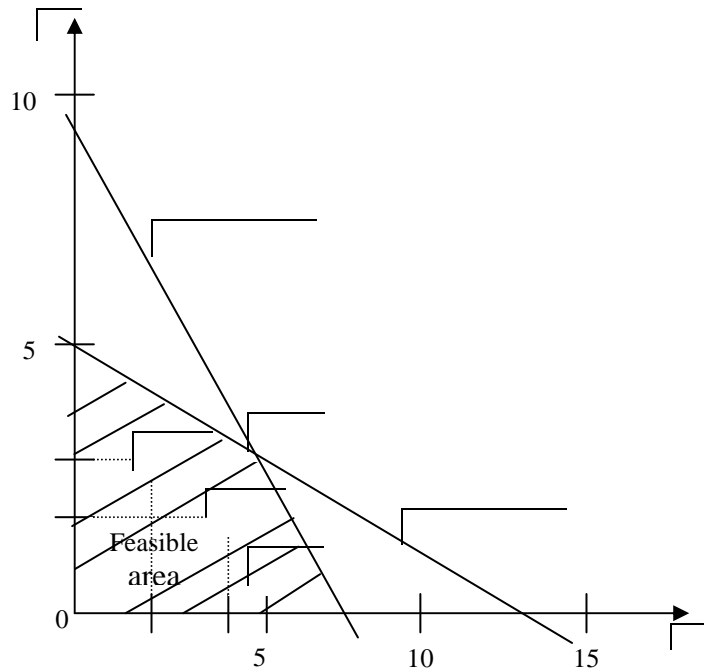

Fig. 1

The constraints give a set of feasible solutions as graphed above. To solve the linear programming problem, we must now find the feasible solution that makes the objective function as large as possible. Some possible solutions are listed below:

Feasible solution (A point in the solution set of the system)	Objective function $R = 4x + 5y$
(2,3)	$4(2) + 5(3) = 8 + 15 = 23$
(4,2)	$4(4) + 5(2) = 16 + 10 = 26$
(5,1)	$4(5) + 5(1) = 20 + 5 = 25$
(7,0)	$4(7) + 5(0) = 28 + 0 = 28$
(0,5)	$4(0) + 5(5) = 0 + 25 = 25$

In this list, the point that makes the objective function the largest is (7,0). But, is this the largest for all feasible solutions? How about (6,1)? or (5,3)? It turns out that (5,3) provide the maximum value: $4(5) + 5(3) = 20 + 15 = 35$.

In Example 6, how did we know that (5,3) provides the maximum value for C ? Obviously, it cannot be done by trial and error as shown in the example. To find the maximum value, some additional theory is needed. Let us begin with some terminology. The set of feasible solutions in Example 6 is called a convex set. A set of points, S , is called convex if, for any two points P and Q in S , the entire segment \overline{PQ} is in S (see diagrams below).

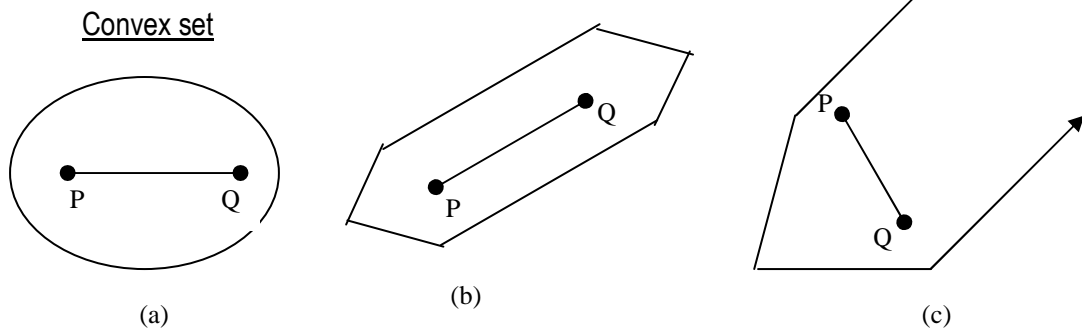

Fig. 2

Set that are not convex

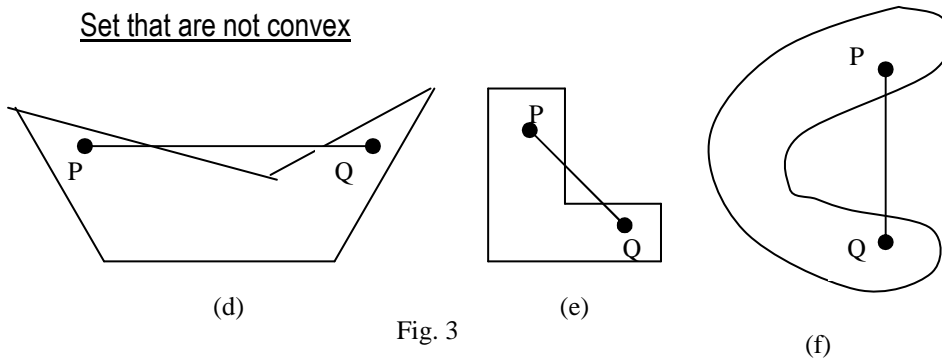
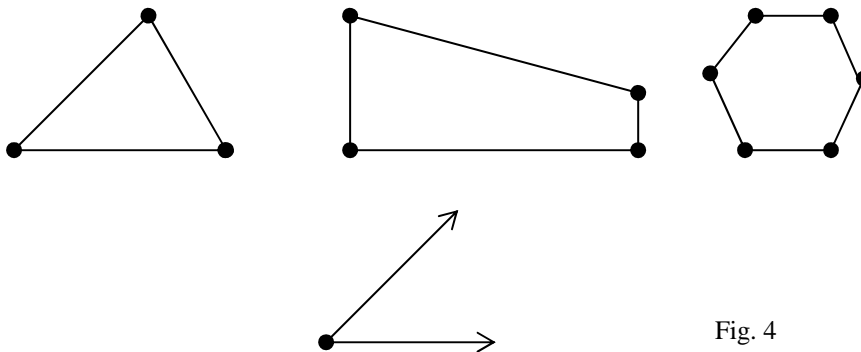

Fig. 3

In linear programming, the boundaries of the sets will be lines or line segments, so we will be dealing with what mathematicians call polygonal convex sets. Part b and c of the diagram above are polygonal convex set (or simply say convex set).

A corner point in a convex set is any point that is the intersection of two boundary lines. The corner points are shown in dot in the diagram below. Notice that convex sets can be bounded or unbounded. A bounded set is one that has finite area.

Corner Points in Convex Sets



EXAMPLE 7

Find the corner points for:

$$2x + 5y \leq 25$$

$$6x + 5y \leq 45$$

$$x \geq 0, y \geq 0$$

This is the set of feasible solution for Example 6 .

SOLUTION

The graph for Example 6 is repeated here and shows the corner points.

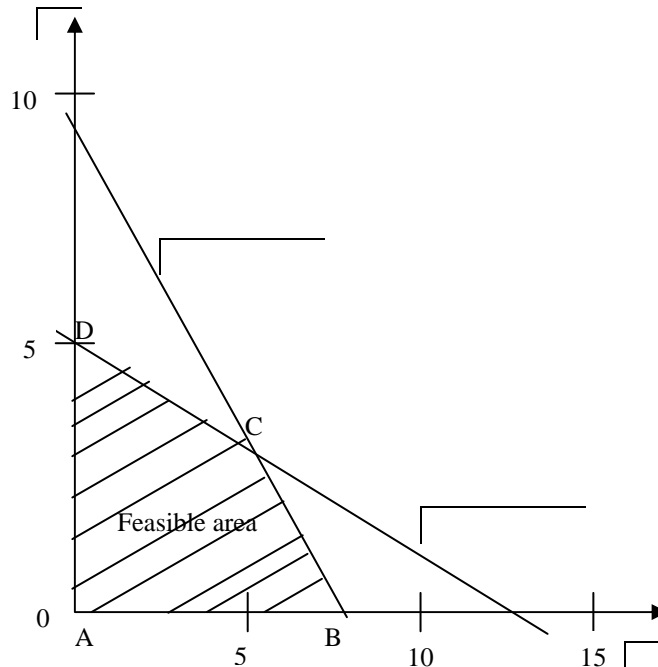

Fig. 5

Some corner points can usually be found by inspection. In this case, we can see $A = (0,0)$ and $D = (0,5)$. Some corner points may require some work with boundary lines (uses equations of boundaries not the inequalities giving the regions).

Point C:

$$\text{System: } 2x + 5y = 25 \dots (1)$$

$$6x + 5y = 45 \dots (2)$$

$$(1) - (2) \Rightarrow -4x = -20$$

$$\Rightarrow x = 5.$$

If $x = 5$, then from (1) or (2):

$$y = 3.$$

Point B:

$$\text{System: } y = 0 \dots (1)$$

$$6x + 5y = 45 \dots (2)$$

Solve by substitution:

$$\Rightarrow 6x + 5(0) = 45$$

$$\Rightarrow x = \frac{45}{6} = 7.5.$$

The corner points for example 7 are: $(0,0)$, $(0,5)$, $(7.5,0)$ and $(5,3)$.

Convex sets and corner points lead us to a method for solving certain linear programming problems.

3.7 Linear Programming Theorem

A linear expression in the variables $c_1x + c_2y$ defined over a convex set S whose sides are line segments, takes on its maximum value at a corner point of S and its minimum value at a corner point of S . If S is unbounded, there may or may not be an optimum value, but if there is, then it must occur at a corner point. In summary, to solve a linear programming problem graphically; the following steps must be taken:

- Find the objective expression (the quantity to be maximized or minimized).
- Find and graph the constraints defined by a system of linear inequalities; the simultaneous solution is called the set S .
- Find the corner points of S ; this may require the solution of a system of two equations with two unknowns, one of each corner points.
- Find the value of the objective expression for the coordinates of each corner point. The largest value is the maximum; the smallest value is the minimum.

EXAMPLE 8

Solve graphically Example 1.

SOLUTION

The linear programming model is:

Maximize: $P = 143x + 60y$

Subject to:

$$x + y \leq 100$$

$$120x + 210y \leq 15000$$

$$110x + 30y \leq 4000$$

$$x \geq 0, y \geq 0.$$

Where x is the number of acres planted in corn and y is the number of acres planted in wheat.

First, graph the set of feasible solutions by graphing the system of inequalities, as shown in the figure:

$$x + y = 100 \text{ [Constraint 1]}$$

When $x = 0, y = 100$ and when $y = 0, x = 100$.

$$120x + 210y = 15000 \text{ [Constraint 2]}$$

When $x = 0, y = \frac{500}{7}$ and when $y = 0, x = 125$.

$$110x + 30y = 4000 \text{ [Constraint 3]}$$

When $x = 0, y = \frac{400}{3}$ and when $y = 0, x = \frac{400}{11}$.

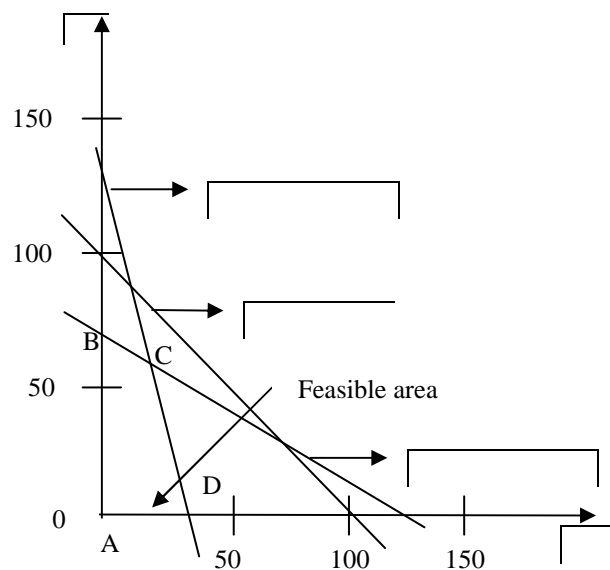

Fig. 6

Next, find the corner points. By inspection, $A = (0,0)$

Point B:

$$\text{System: } 120x + 210y = 15000 \dots (1)$$

$$x = 0 \dots (2)$$

Solve (1) and (2) simultaneously by substituting for

$x = 0$ in (1):

$$\Rightarrow 120(0) + 210y = 15000$$

$$\Rightarrow y = \frac{15000}{210} = \frac{500}{7}.$$

$$\text{Point B: } \left(0, \frac{500}{7}\right).$$

Point C:

$$\text{System: } 110x + 30y = 4000 \dots (1)$$

$$120x + 210y = 15000 \dots (2)$$

$$7(1) - (2) \Rightarrow 650x = 13000$$

$$\Rightarrow x = 20.$$

Substitute for $x = 20$ in (1):

$$\Rightarrow 110(20) + 30y = 4000$$

$$\Rightarrow 30y = 1800.$$

$$\therefore y = 60$$

$$\text{Point C: } (20,60).$$

Point D:

$$\text{System: } 110x + 30y = 4000 \dots (1)$$

$$y = 0 \dots (2)$$

Solve (1) and (2) simultaneously by substituting for

$y = 0$ in (1):

$$\Rightarrow 110x + 30(0) = 4000.$$

$$\Rightarrow 110x = 4000$$

$$\therefore x = \frac{400}{11}$$

Point D: $\left(\frac{400}{11}, 0\right)$.

Use the linear programming theorem and check the corner points:

Corner point	Objective function $P = 143x + 60y$
(0,0)	$143(0) + 60(0) = 0$
$\left(0, \frac{500}{7}\right)$	$143(0) + 60\left(\frac{500}{7}\right) = 4,286$
$\left(\frac{400}{11}, 0\right)$	$143\left(\frac{400}{11}\right) + 60(0) = 5,200$
(20,60)	$143(20) + 60(60) = 6,460$

The maximum value of P is 6,460 at (20,60). This means that to maximum profit, the farmer should plant 20 acres in corn, plant 60 acres in wheat and leave 20 acres unplanted.

Notice from the graph in Example 8 that some of the constraints could be eliminated from the problem and everything else would remain unchanged. For example, the boundary $x + y = 100$ was not necessary in finding the maximum value of P. Such a condition is said to be a superfluous constraint. It is not uncommon to have superfluous constraints in a linear programming problem. Suppose, however, that the farmer in Example 1 contracted to have the grain stored at neighboring farm and now the contract calls for at least 4,000 bushels to be stored. This change from $110x + 30y \leq 4000$ to $110x + 30y \geq 4000$, now makes the condition $x + y \leq 100$ important to the solution of the problem. Therefore, you must be careful about superfluous constraints even though they do not affect the solution at the present time.

EXAMPLE 9

Solve the following linear programming problem:

Minimize: $C = 60x + 30y$

Subject to:

$$2x + 3y \geq 120$$

$$2x + y \geq 80$$

$$x \geq 0, y \geq 0.$$

SOLUTION

Fig. 7

Corner points $A = (0,80)$ and $C = (60,0)$ are found by inspection.

Point B:

System: $2x + 3y = 120 \dots (1)$

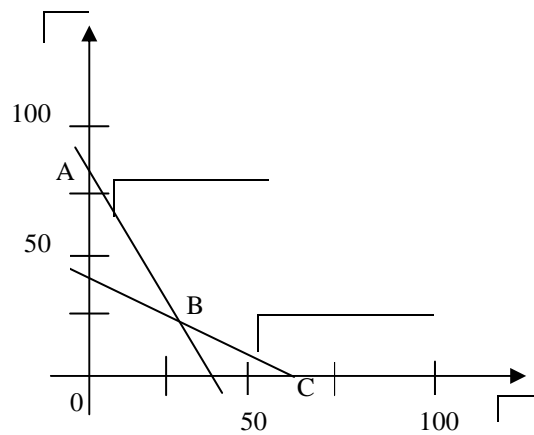
$$2x + y = 80 \dots (2)$$

$$(1) - (2) \Rightarrow 2y = 40$$

$$\Rightarrow y = 20.$$

Substitute for $y = 20$ in (2):

$$\Rightarrow 2x + 20 = 80.$$

$$\Rightarrow 2x = 60.$$

$$\Rightarrow x = 30.$$

Point B: $(30,20)$.

Extreme values.

Corner point	Objective function $C = 60x + 30y$
(0,80)	$60(0) + 30(80) = 2400$
(30,20)	$60(30) + 30(20) = 2400$
(60,0)	$60(60) + 30(0) = 3600$

From the table above, there are two minimum values for the objective function: $A = (0,80)$ and $B = (30,20)$. In this situation, the objective function will have the same minimum value (2,400) at all points along the boundary line segment A and B.

Special Cases

Linear programming problems do not always yield a unique optimal solution. There are a number of special cases and we shall consider just two of them:

- i. No feasible solution and;
- ii. Multiple optimum solutions.

No Feasible Solution

If the constraints are mutually exclusive, no feasible area can be defined and no optimum solution can exist. Consider again the maximization problem.

EXAMPLE 10

Maximize: $z = 2x + 3y$

Subject to:

$$x + 2y \leq 40$$

$$6x + 5y \leq 150$$

$$x \geq 0, y \geq 0$$

SOLUTION

The feasible area is defined by the constraints as shown in the figure below.

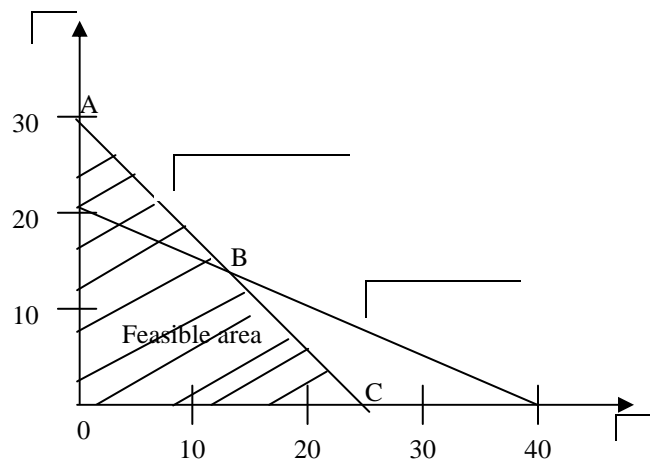

Fig. 8

Suppose that in addition to the existing constraints, the company is contracted to produce at least 30 units each week. This additional constraint can be written as: $x + y \geq 30$. As a boundary solution, the constraint would be: $x + y = 30$, $(x = 0, y = 30)(x = 30, y = 0)$. The three structural constraints are shown in the figure below. This case presents the manager with demands which cannot simultaneously be satisfied.

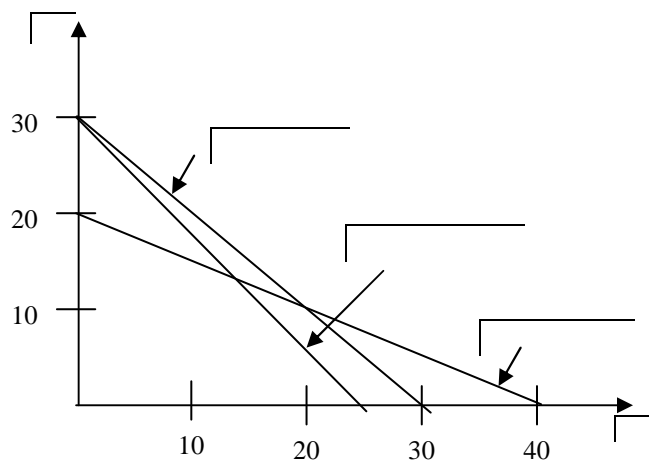

Fig. 9

Multiple Optimum Solutions

A multiple optimum solution results when the objective function is parallel to one of the boundary constraints. Consider the following problem.

EXAMPLE 11

Minimize: $z = 600x + 900y$

Subject to:

$$40x + 60y \geq 480$$

$$30x + 15y \geq 180$$

$$x \geq 0, y \geq 0$$

SOLUTION

If we let $z = \$8100$, then:

$$8100 = 600x + 900y, (x = 0, y = 9)(x = 13.5, y = 0).$$

The resultant trial cost is shown in the figure below.

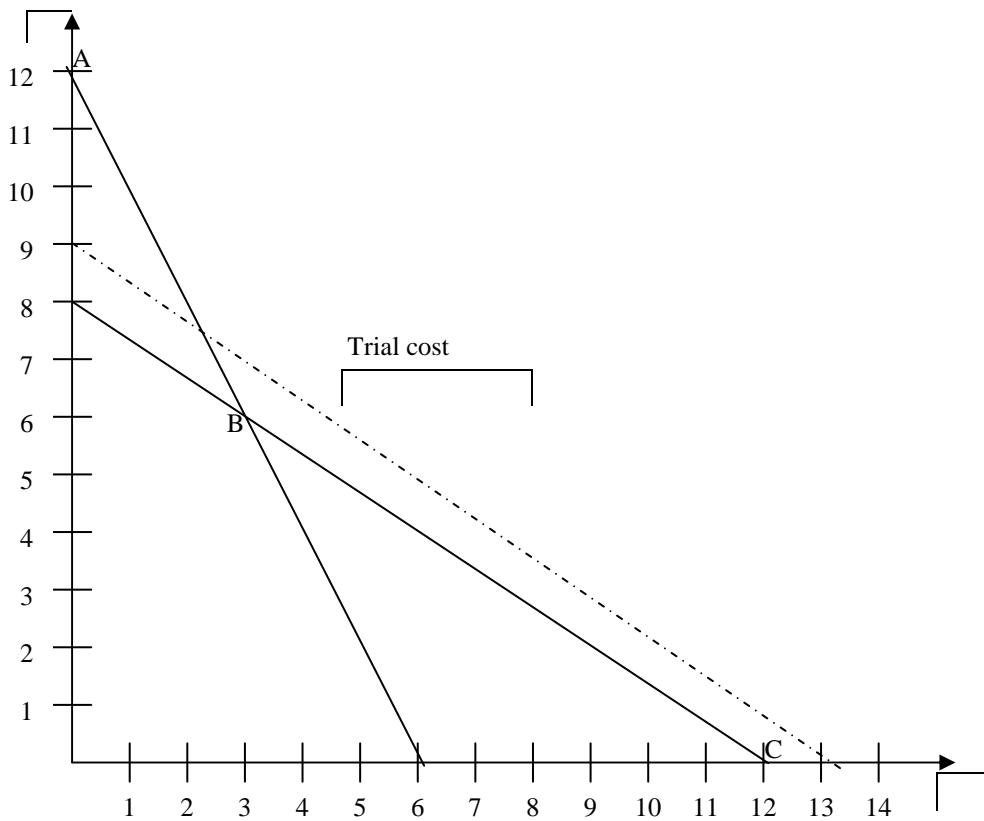

Fig. 10

This line is parallel to the boundary line BC. The lowest acceptable cost solution will be coincidental with the line BC making point B, point C and any other points on the line BC optimal. Multiple optimum solutions present the manager with choice and hence some flexibility.

The value of Resources

Linear programming provides a method for evaluating the marginal value of resources. Consider yet again the maximization problem.

EXAMPLE 12

Maximize: $z = 2x + 3y$

Subject to:

$$x + 2y \leq 40 \text{ (Labour hours)}$$

$$6x + 5y \leq 150 \text{ (Moulding material)}$$

$$x \geq 0, y \geq 0$$

In this case, the solution is limited by the 40 hours of labour and the 150 litres of moulding material. To assess the value of additional resources, we can consider what difference it would make if we could provide an extra hour of labour or an extra unit of moulding material. The amount added to profit in this case (or more generally, z in the objective function) as a result of the additional unit of resources is seen as the marginal value of the resources and is referred to as the “opportunity cost” or the “shadow price”.

To determine the shadow price of labour, we would increase the hours available from 40 to 41. The linear programming formulation now becomes:

Maximize: $z = 2x + 3y$

Subject to:

$$x + 2y \leq 41$$

$$6x + 5y \leq 150$$

$$x \geq 0, y \geq 0$$

This type of marginal analysis is difficult to show graphically because of the small movements involved. Effectively, the labour constraint has moved outwards and can be plotted using the points $(x = 0, y = 20.5)$ and $(x = 41, y = 0)$.

The new solution is $x = 13\frac{4}{7}$ and $y = 13\frac{5}{7}$.

The new level of profit can be found by substitution into the objective function, thus:

$$z = \left(\#2 \times 13\frac{4}{7} \right) + \left(\#3 \times 13\frac{5}{7} \right) = \#68.29.$$

The increase in profit resulting from the additional hour of labour, or shadow price of labour, is the difference between the new profit and the old profit i.e. $\#(68.29 - 67.14) = \#1.15$.

To determine the shadow price of materials, we would increase the number of litres available from 150 to 151. The linear programming formulation now becomes:

Maximize: $z = 2x + 3y$

Subject to:

$$x + 2y \leq 40$$

$$6x + 5y \leq 151$$

$$x \geq 0, y \geq 0$$

In this case, it is the material constraint that would move outwards while the labour constraint remained unchanged at 40 hours. To plot the new material constraint, the points $(x = 0, y = 30.2)$ and $(x = 25.17, y = 0)$ may be used.

The new solution is $x = 14\frac{4}{7}$ and $y = 12\frac{5}{7}$.

The new level of profit can be found by substitution into the objective function, thus:

$$z = \left(\#2 \times 14\frac{4}{7} \right) + \left(\#3 \times 12\frac{5}{7} \right) = \#67.29.$$

The increase in profit resulting from the additional litre of moulding material, or shadow price of material, is the difference between the new profit and the old profit i.e.

$$\#(67.29 - 67.14) = \#0.15.$$

If the manager were to pay below #1.15 for the additional hour of labour (unlikely to be available at these rates!), then profits could be increased, and if the manager were to pay above this figure, then profits would decrease. Similarly, if the manager can pay below #0.15 for an additional unit of moulding material, then profits can be increased but if the manager were to pay above this level, then profits would decrease. It is useful to see the effect of increasing both labour and materials by one unit.

The linear programming formulation now becomes:

Maximize: $z = 2x + 3y$

Subject to:

$$x + 2y \leq 41$$

$$6x + 5y \leq 151$$

$$x \geq 0, y \geq 0$$

The new solution is $x = 13\frac{6}{7}$ and $y = 13\frac{4}{7}$.

The new level of profit is $z = \left(2 \times 13\frac{6}{7}\right) + \left(3 \times 13\frac{4}{7}\right) = \text{\#}68.43$.

The increase in profit is $\text{\#}(68.43 - 67.14) = \text{\#}1.29$.

This increased profit (subject to the small rounding error of #0.01) is the sum of the shadow prices $\text{\#}(1.15 + 0.15)$. It should be noted that, the shadow prices calculated only apply while the constraints continue to work in the same way. If, for example, we continue to increase the supply of moulding material (because it can be obtained at a market price below the shadow price), other constraints may become active and change the value of the shadow price.

4.0. CONCLUSION

As in the summary.

5.0. SUMMARY

- * Linear programming is an aspect of operations research that utilizes the construction of a mathematical model to solve allocation problem.
- * Linear programming model have four properties, viz: Objective function, Alternative decision variables, Constraint and linear representations of the objective function and the constraints.
- * In formulating a mathematical model we follow these steps:
 - (i) Identification of decision variables
 - (ii) Statement of the objective function
 - (iii) Statement of the constraint
- * Graphical method can only be use to solve a linear programming

model involving two decision variables.

6.0. TUTOR MARKED ASSIGNMENT

1. In relation to Linear Programming, explain the implication of the following assumptions of the model:
 - (i) Linearity of the objective function and constraints
 - (ii) Certainty and (iii) Decision variables
2. Orient Paper Mills produces two grades of paper X and Y. Because of raw material restrictions not more than 400 tons of grade X and not more than 300 tons of grade Y can be produced in a week. There are 160 production hours in a week. It requires 0.2 and 0.4 hour to produce a ton of products X and Y respectively. With corresponding profit of \$20 and \$50 per ton.
Required:
 - (a) Formulate a linear programming model to optimize the product mix for maximum profit.
 - (b) Solve graphically the model in (a) above.

7.0. REFERENCES/FURTHER READINGS

1. Operations Research. By Prem Kumar Gupta and D.S. Hira
2. Operations Research. (Problem Solvers) By Research and Education Association.
7. Statistics and Operations Research. By Debashis Dutta
8. Operations Research By). O.T. Arowolo and G.O. Lawal

UNIT 4 LINEAR PROGRAMMING (SIMPLEX METHOD) 2

1.0. Introduction

2.0. Objective

3.0. Main Content

3.1. Various steps in solving or problems using simplex method.

(a) Maximisation problems

(b) Minimisation problems

3.2. MINIMISATION PROBLEMS (ALL CONSTRAINTS OF THE TYPE \geq)
BIG 'M' METHOD.

3.3. MINIMISING CASE – CONSTRAINTS OF MIXED TYPES (\leq AND \geq)

3.4. Maximisation case-constraints of mixed type

4.0. Conclusion

5.0. Summary

6.0. Tutor Marked Assignment

7.0. Reference/ Further Readings

1.0 INTRODUCTION

We have seen in the chapter on Linear Programming Problems that one can conveniently solve problems with two variables. If we have more than two variables, the solution becomes very cumbersome and complicated. Thus, there is a limitation of LPP.

Simplex method is an algebraic procedure in which a series of repetitive operation are used and we progressively approach the optimal solution. Thus, this procedure has a number of steps to find the solution to any problems consisting of any number of variables and constraints, however problems with more than 4 variables cannot be solved manually and require the use of computer for solving them.

This method developed by the American mathematician G B Dantzig, can be used to solve any problem, which has a solution. The process of reaching the optimal solution through different stages is also called iterative, because the same computational steps are repeated a number of times before the optimum

2.0 OBJECTIVE

- * Preparation of LPD for use of simplex
- * Understanding of the need of use of simplex
- * Steps involve in using a simplex method.
- * Preparing a simplex Table and understanding its various components.
- * Demonstrating the use of simplex method for solving a LLP
- * Solving LPP using maximization problem

3.0 MAIN TEXT

3.1.VARIOUS STEPS IN SOLVING OR PROBLEM USING SIMPLE METHOD.

Step 1. Formulate the problem

The problem must be put in the form of a mathematical model. The standard form of the LP model has the following proprieties

- a An objective function, which has to maximized or minimized
- b All the constraints can be put in the form equations.
- c All the variables are non-negative.

Step II. Set up the initial simple table with slack variable or surplus variables in the solution.

A constraint of type \leq or \geq can be converted into an equation by adding a slack variable or subtracting a surplus variable on the left hand side of the constraint.

For example, in the constraint $X_1 + 3X_2 \leq 15$ we add a slack $S_1 \geq 0$ To The left side to obtain an equation : $X_1 + 3X_2 + S_1 = 15, S_1 \geq 0$

Now consider the constraint $2X_1 + 3X_2 - X_3 = \geq 4$, since the left side is not smaller than the right side we subtract a surplus variable $S_2 > 0$ form the left side to obtain the equation

$$2X_1 + 3X_2 - X_3 - S_2 = 4, S_2 \geq 0$$

The use of the slack variable or surplus variable will become clear in the actual example as we proceed.

Step III. Determine the decision variables which are to be brought in the solution

Step IV. Determine which variable to replace.

Step V. Calculation new row values for entering variables

Step VI. Revise remaining rows.

Repeat sep III to VI till an optimal solution is obtained . This procedure can best be explained with the help of a suitable example.

Example 1 Solve the following linear programming problem by simplex method.

$$\begin{aligned}
&\text{Maximize} && Z = 10X_1 + 20X_2 \\
&\text{Subject to the following constraints} \\
&&& 3X_1 + 2X_2 \leq 1200 \\
&&& 2X_1 + 6X_2 \leq 1500 \\
&&& X_1 \leq 350 \\
&&& X_2 \leq 200 \\
&&& X_1, X_2 > 0
\end{aligned}$$

Solution

Step 1. formulate the problem

Problem is already stated in the mathematical model.

Step 2. Set up the initial simplex table with the slack variables in solution. By introducing the slack variables, the equation in step I, *i.e.* the mathematical model can be rewritten as follows

$$\begin{aligned}
3X_1 + 2X_2 + S_1 &= 1,200 \\
2X_1 + 6X_2 + S_2 &= 1,500 \\
X_1 + S_3 &= 350 \\
X_2 + S_4 &= 200
\end{aligned}$$

Where S_1, S_2, S_3 and S_4 are the slack variables. Let us re- write the above equation in symmetrical manner so that all the four slacks S_1, S_2, S_3 and S_4 appear in all equation

$$\begin{aligned}
3X_1 + 2X_2 + 1S_1 + 0S_2 + 0S_3 + 0S_4 &= 1,200 \\
2X_1 + 6X_2 + 0S_1 + 1S_2 + 0S_3 + 0S_4 &= 1,500 \\
1X_1 + 0X_2 + 0S_1 + 0S_2 + 1S_3 + 0S_4 &= 350 \\
0X_1 + 1X_2 + 0S_1 + 0S_2 + 1S_3 + 0S_4 &= 200
\end{aligned}$$

Let us also write the objective function Z by introducing the slack in it.

$$Z = 10X_1 + 20X_2 + 0S_1 + 0S_2 + 1S_3 + 0S_4$$

The first simplex table can now be written as.

Table 1

C ₁	Solution	# 10	# 20	0	0	0	0	Contribution unit quantity
	Mix	X ₁	X ₁	S ₁	S ₂	S ₃	S ₄	
0	S ₁	3	2	1	0	0	0	1200
0	S ₂	2	6	0	1	0	0	1500

0	S ₃	1	0	0	0	1	0	350
0	S ₄	0	1	0	0	0	1	200 Key Row ←
Z _j (C _j - Z _j)		0	0	0	0	0	0	0
		10	20	0	0	0	0	
			↑ Key Column					

The first simplex table is shown in Table 1. The table is explained as below.

1. Row 1 contains C or the contribution to total profit with the production of one unit of each product X₁ and X₂. This row gives the coefficients of the variables in the objective function which will remain the same. Under column 1(C_j) is provided profit unit of 4 variables S₁ S₂ S₃ S₄ which is zero.
2. All the variables S₁, S₂, S₃, S₄ are listed under solution Mix. Their profit is zero and written under column 1 (C_j) as explained above.
3. The constraints variables are written to the right of solution mix. These are X₁ X₂ S₁, S₂, S₃ and S₄ Under these are written coefficient of variable and under each are written the coefficients X₁, X₂, S₁, S₂, S₃ and S₄ in first constraint equation are 3,2,1,0,0 and 0, respectively which are written under these variables in the first level. Similarly,, the remaining 3 rows represents the coefficient of the variables as they appear in the other 3 constraint equation The entries in the quantity column represent the right hand side of each constraint equation. These values are 1,200, 1,500, 350 and 200 receptivity, for the given problem.
4. The Z_j values in the second row form the bottom refer to the amount of gross profit that is given up by the introducing one unit the solution. The subscript j refer to the specific variable being considered. The Z_j values under the quantity column is the total profit for their solution. In the initial column all the Z_j - values will be zero because no real product is being manufactured and hence there is on gross profit to be lost if they are replaced.

5. The bottom row of the table contains net profit per unit obtained by introducing one unit of a given variable into the solution. This row is designated as the $C_j - Z_j$ row. The procedure for calculating Z_j and $C_j - Z_j$ values is given below.

Calculation of Z_j

$C_j \times X_1$	$C_j \times X_2$	$C_j \times S_1$
$0 \times 3 = 0$	$0 \times 2 = 0$	$0 \times 1 = 0$
	+	+
$0 \times 2 = 0$	$0 \times 6 = 0$	$0 \times 0 = 0$
	+	+
$0 \times 1 = 0$	$0 \times 0 = 0$	$0 \times 0 = 0$
	+	+
<u>$0 \times 0 = 0$</u>	<u>$0 \times 1 = 0$</u>	<u>$0 \times 0 = 0$</u>
$Z_{X_1} = 0$	$Z_{X_2} = 0$	$Z_{S_1} = 0$

Similarly, Z_{S_2} , Z_{S_3} and Z_{S_4} can be calculated as 0 each

Calculation of $C_j - Z_j$

$$C_{X_1} - Z_{X_1} = 10 - 0 = 10$$

$$C_{X_2} - Z_{X_2} = 20 - 0 = 20$$

$$C_{S_1} - Z_{S_1} = 0 - 0 = 0$$

$$C_{S_2} - Z_{S_2} = 0 - 0 = 0$$

$$C_{S_3} - Z_{S_3} = 0 - 0 = 0$$

$$C_{S_4} - Z_{S_4} = 0 - 0 = 0$$

The total profit for this solution is # zero.

Step 3.

Determine the variable to be brought into the solution. An improved solution is possible if there is a positive value in $C_j - Z_j$ row. The variable with the largest positive value in the $C_j - Z_j$ row is subjected as the objective is to maximize the profit, The column associated with this variable is referred to as 'Key column' and is designated by a small arrow beneath this column. In the given example, 20 is the largest possible value corresponding to X_2 which is selected as the key column.

Step 4.

Determine which variable is to be replaced. To make this determination, divide each amount in the contribution quantity column by the amount in the comparable row of Key column, X_2 and choose the variable associated with smallest quotient as the one to be replace. In the given example, these value are calculated as

for the S_1 row – $1200/2 = 600$

for the S_2 row – $1500/6 = 250$

for the S_3 row – $350/2 = \infty$

for the S_4 row – $200/1 = 200$

Since the smallest quotient is 200 corresponding to S_4 , S_4 will be replaced, and its row is identified by the small arrow to the right of the table as shown. The quotient represents the maximum value of X which could be brought into the solution.

Step 5.

Calculate the new row values for entering the variable. The introduction of X_2 into the solution requires that the entire S_4 row be replaced. The values of X_2 , the replacing row, are obtained by dividing each value presently in the S_4 row by the value in column X_2 in the same row. This value is termed as the key or the pivotal element since it occurs at the intersection of key row and key column.

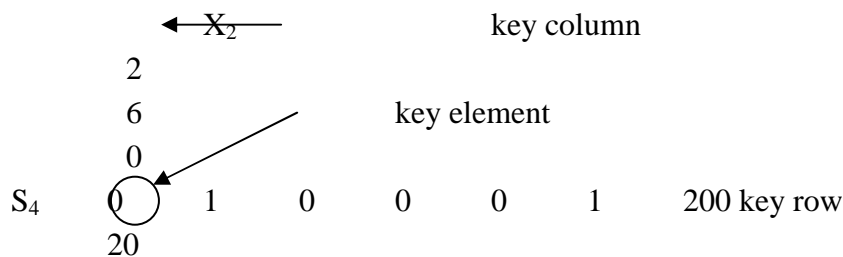

The row values entering variable X_2 can be calculated as follows:
 $0/1 = 0$; $1/1 = 1$; $0/1 = 0$; $0/1 = 0$; $0/1 = 0$; $-1/1 = 1$; $200/1 = 200$

Step 6.

Update the remaining rows. The new S_2 row values are 0, 1, 0, 0, 1 and 200 which are same as the previous table as the key element happens to be 1. The introduction of a new variable into the problem will affect the values of remaining variables and a

second set of calculations need to be performed to update the initial table. These calculations are performed as given here:

Updated S_1 row = old S_1 row – intersectional element of old S_1 row x corresponding element of new X_2 row.

$$\begin{aligned}
 &= 3 - [2 \times 0] = 3 \\
 &= 2 - [2 \times 1] = 0 \\
 &= 1 - [2 \times 0] = 1 \\
 &= 0 - [2 \times 0] = 0 \\
 &= 0 - [2 \times 0] = 0 \\
 &= 0 - [2 \times 1] = -2 \\
 &= 1200 - [2 \times 200] = 800
 \end{aligned}$$

Similarly, the updated elements of S_2 and S_3 rows can be calculated as follows:

	Elements of updated S_2 row	Elements of updated S_3
row		
	$2 - [6 \times 0] = 2$	$1 - [0 \times 0] = 1$
	$6 - [6 \times 1] = 0$	$0 - [0 \times 1] = 0$
	$0 - [6 \times 0] = 0$	$0 - [0 \times 0] = 0$
	$1 - [6 \times 0] = 1$	$0 - [0 \times 0] = 0$
	$0 - [6 \times 0] = 0$	$1 - [0 \times 0] = 1$
	$0 - [6 \times 1] = -6$	$0 - [0 \times 1] = 0$
	$1500 - [6 \times 200] = 300$	$350 - [0 \times 200] = 350$

Rewiring the second simplex table with the updated elements as shown in Table 2. below

Table 2

	Solution	# 10	# 20	0	0	0	0	Contribution	
C_i	Mix	X_1	X_2	S_1	S_2	S_3	S_4	Quantity	Ratio
0	S_1	3	0	1	0	0	-2	800	266.7
0	S_2	2	0	0	1	0	-6	300	150 →
0	S_3	1	0	0	0	1	0	350	350
20	X_2	0	1	0	0	0	1	200	∞
	Z_j	0	20	0	0	0	20	400	
	$(C_j - Z_j)$	10 ↑	0	0	0	0	-20		

The new variable entering the solution would be X_1 . It will replace the S_2 row which can be shown as follows:

- for the S_1 row – $800/2 = 266.7$
- for the S_2 row – $300/6 = 150$
- for the S_3 row – $350/2 = 350$
- for the S_4 row – $200/1 = \infty$

As the quotient 150 corresponding of S_2 row is the minimum, it will be replaced by X_1 in the new solution. The corresponding elements of S_2 row can be calculated as follows:

		X_1							
		3				Key element			
S_2	2	0	0	0	0	1	0	-6	300 Key row
		1							
		0							
	0								
	10								
									Key column

New element of S_2 row to be replaced by X_1 are
 $2/2 = 1$; $0/2 = 0$; $0/2 = 0$; $1/2 = 1/2$; $0/2 = 0$; $-6/2 = -3$; $300/2 = 150$;
 The updated elements of S_1 and S_3 rows can be calculated as follows:

<p>Elements of updated S_1 row</p> $3 - [3 \times 1] = 0$ $0 - [3 \times 0] = 0$ $1 - [3 \times 0] = 1$ $1 - [3 \times 1/2] = -3/2$ $0 - [3 \times 0] = 0$ $-2 - [3 \times 3] = -7$ $800 - [3 \times 150] = 350$	<p>Elements of updated S_3 row</p> $1 - [1 \times 1] = 0$ $0 - [1 \times 0] = 0$ $0 - [1 \times 0] = 0$ $0 - [1 \times 1/2] = 1/2$ $1 - [1 \times 0] = 1$ $0 - [1 \times -3] = 3$ $350 - [1 \times 150] = 200$
--	--

Elements of updated X_2 row

$$0 - [0 \times 1] = 0$$

$$1 - [0 \times 0] = 1$$

$$0 - [0 \times 0] = 0$$

$$0 - [0 \times 1/2] = 0$$

$$0 - [0 \times 0] = 0$$

$$1 - [0 \times -3] = 1$$

$$200 - [0 \times 150] = 200$$

Revised simplex table can now be written as shown in Table 3 below:

C_i	Solution	# 10	# 20	0	0	0	0	Contribution	Min
	Mix	X_1	X_2	S_1	S_2	S_3	S_4	Quantity	Ratio
0	S_1	0	0	1	-3/2	0	7	350	50
10	X_1	1	0	0	1/2	0	-3	150	-50
0	S_3	0	0	0	-1/2	1	3	200	66.7
20	X_2	0	1	0	0	0	1	200	200
	Z_j	10	20	0	5	0	-10	5500	
	$(C_j - Z_j)$	0	0	0	-5	0	10		

Now the new entering variable will be S_4 and it will replace S_1 as shown below:

$$350/7 = 50$$

$$150/-3 = -50$$

$$200/3 = 66.7$$

$$200/1 = 200$$

In these figures, 50 represent the minimum quotient which corresponds to row S_1 . The negative sign is not considered.

The new elements of S_1 row to be replaced by S_4 can be calculated as follows:

S_1	0	0	1	-3/2	0	7	350	key
row								
						-3		
						3		
						1		
						-10		
						10		
							Key column	

The new elements of S_4 row would be

$$0/7 = 0; 0/7 = 0; 1/7 = 1/7; (-3/2) \times (1/7) = -3/14; 0/7 = 0; 1; 7/7 = 1; 350/7 = 50$$

The updated elements of the other rows can be calculated as follows:

Elements of updated X_1 row

$$1 - [-3 \times 0] = 1$$

$$0 - [-3 \times 0] = 0$$

$$0 - [-3 \times 1/7] = 3/7$$

$$\frac{1}{2} - [-3 \times 3/14] = 1/7$$

$$0 - [-3 \times 0] = 0$$

Elements of updated S_3 row

$$0 - [3 \times 0] = 0$$

$$0 - [3 \times 0] = 0$$

$$0 - [3 \times 1/7] = 3/7$$

$$-\frac{1}{2} - [3 \times 3/14] = -1/7$$

$$1 - [3 \times 0] = 1$$

$$3 - [3 \times -1] = 0$$

$$300 - [3 \times 50] = 50$$

$$-3 - [-3 \times 1] = 0$$

$$150 - [-3 \times 50] = 300$$

Elements of updated X₂ row

$$0 - [1 \times 0] = 0$$

$$1 - [1 \times 0] = 1$$

$$0 - [1 \times 1/7] = 1/7$$

$$0 - [1 \times -3/14] = 3/14$$

$$0 - [1 \times 0] = 0$$

$$1 - [1 \times 1] = 0$$

$$200 - [1 \times 50] = 150$$

Revised simplex table can now be written as shown in Table 4 below:

	Solution	# 10	# 20	0	0	0	0	Contribution
C_i	Mix	X₁	X₂	S₁	S₂	S₃	S₄	Quantity
0	S ₄	0	0	1/7	-3/14	0	1	50
10	X ₁	1	0	3/7	-1/7	0	0	300
0	S ₃	0	0	-3/7	1/7	1	0	50
20	X ₂	0	1	-1/7	3/14	0	0	150
	Z _j	10	20	10/7	40/14	0	0	6,000
	(C _j - Z _j)	0	0	-10/7	-40/14	0	0	

As there is no positive value in C_j - Z_j row it represents the optimal solution, which is given as:

$$X_1 = 300 \text{ units} : X_2 = 150 \text{ units}$$

And the maximum profit Z = # 6,000

Minimization problems.

Identical procedure is followed for solving the minimization problems. Since the objective is to minimize rather than maximize, a negative (C_j - Z_j) value indicates potential improvement. Therefore, the variable associated with largest negative (C_j - Z_j) value would be brought into the solution first. Additional variables are brought in to set up such problems. However, such problems involve greater than or equal to constraints, which need to be treated separately from less than or equal to constraints, which are typical of maximization problems. In order to convert such inequalities, the following procedure may be adopted.

For example, if the constrain equation is represented as:

$$3X_1 + 2X_2 > 1200$$

To convert this into equality, it would be written as:

$$3X_1 + 2X_2 - S_1 = 1200$$

Where S_1 is a slack variable. However, this will create a difficulty in the simplex method because of the fact that the initial simplex solution starts with slack variables and a negative value ($-1S_1$) would be in the solution, a condition which is not permitted in linear programming. To overcome this problem, the simplex procedure requires that another variable known as artificial variable be added to each equation in which a slack variable is subtracted. An artificial variable may be thought of as representing a fictitious product having very high cost which though permitted in the initial solution to a simplex problem, would never appear in the solution. Defining A as an artificial variable, the constraint equation can be written as:

$$3X_1 + 2X_2 - 1S_1 + 1A_1 = 1200$$

Assuming the objective function is to minimize cost, it would be written as:

$$10X_1 + 20X_2 - 0S_1 + MA_1 \text{ to be minimized}$$

Where M is assumed to be very large cost (say, 1 million). Also S_1 is added to the objective function even though it is negative in constraint equation. An artificial variable is also added to constraint equations with equality sign, e.g. if the constraint equation is

$$3X_1 + 2X_2 = 1200$$

then, in simplex it would change to

$$3X_1 + 2X_2 + 1A_1 = 1200$$

to satisfy simplex requirement and would be reflected as MA in the objective function

Example 2

ABC company manufactures and sells two products P_1 and P_2 . Each unit of P_1 requires 2 hours of machining and 1 hour of skilled labour. Each unit of P_2 requires 1 hour of machining and 2 hours of labour. The machine capacity is limited to 600 machine hours and skilled labour is limited to 650 man hours. Only 300 units of product P_1 can be sold in the market. You are required to

- Develop a suitable model to determine the optimal product mix
- Find out the optimal product mix and the maximum contribution. Unit contribution from product P_1 is # 8 and from product P_2 is # 12.
- Determine the incremental contribution / unit of machine-hours, per unit of labour and per unit of product P_1 .

Solution

Step 1. Formulation of LP model

Let X_1 and X_2 be the number of units to be manufactured of the two products P_1 and P_2 respectively. We are required to find out the number of units of the two products to be manufactured to maximize contribution, i.e., profits when individual contribution of the two products are given. LP model can be formulated as follows:

$$\begin{aligned} & \text{Maximize } Z = 8X_1 + 12X_2 \\ & \text{Subject to conditions/constraints} \\ & 2X_1 + X_2 \leq 600 \text{ (Machine time constraint)} \\ & X_1 + 2X_2 \leq 650 \text{ (Labour-time constraint)} \\ & X_1 \leq 300 \text{ (marketing constraint of product } P_1) \end{aligned}$$

Step 2. Converting constraints into equations

LP problem has to be written in a standard form, for which the inequalities of the constraints have to be converted into equations. For this purpose, we add a slack variable to each constraint equation. Slack is the unused or spare capacity for the constraints to which it is added. In less than (\leq) type of constraint, the slack variable denoted by S , is added to convert inequalities into equations. S is always a non-negative figure or 0. If S is negative, it may be seen that the capacity utilized will exceed the total capacity, which is absurd. The above inequalities of this problem can be rewritten by adding suitable slack variables and converted into equations as shown below.

$$\begin{aligned} 2X_1 + X_2 + S_1 &= 600 \\ X_1 + 2X_2 + S_2 &= 650 \\ X_1 + S_3 &= 300 \\ X_1, X_2, S_1, S_2, S_3 &> 0 \end{aligned}$$

Slack variables S_1 , S_2 and S_3 contribute zero to the objective function since they represent only unused resources. Let us include these slack variables in the objective function. Then maximize: $Z = 8X_1 + 12X_2 + 0S_1 + 0S_2 + 0S_3$

Step 3. Set up the initial solution

Let us recollect that the computational procedure in the simplex method is based on the following fundamental property.

“The optimal solution to a Linear Programming problem always occurs at one of three corner points of the feasible solution space”.

It means that the corner points of the feasible solution region can provide the optimal solution. Let the search start with the origin which means nothing is produced at origin (0, 0) and the value of decision variable X_1 and X_2 is zero. In such a case, $S_1 = 600$, $S_2 = 650$, $S_3 = 300$ are the spare capacities as nothing (0) is being produced. In the solution at origin we have two variables X_1 and X_2 with zero value and three variables (S_1 , S_2 and S_3) with specific value of 600, 650 and 300. The variables with non-zero values, i.e. S_1 , S_2 and S_3 are called the **basic variables** where as the other variables with zero values i.e. X_1 , X_2 and X_3 are called **non-basic variables**. It can be seen that the number of basic variables is the same as the number of constraints equations (three in the present problem). The solution with basic variables is called

basic solution which can be further divided into Basic Feasible Solution and Basic Infeasible Solution. The first type of solutions are those which satisfy all the constraints. In Simplex Method, we search for basic feasible solution only.

Step 4. Developing initial simplex table

The initial decision can be put in the form of a table which is called a Simplex Table or Simplex Matrix. The details of the matrix are as follows

- (1) Row 1 contains C_j or the contribution to total profit with the production of one unit of each product P_1 and P_2 . Under column 1 (C_j) are listed the profit coefficients of the basic variables. In the present problem, the profit coefficients of S_1 , S_2 and S_3 are zero.
- (2) In the column labeled Solution Mix or Product Mix are listed the variables S_1 , S_2 and S_3 , their profits are zero and written under column 1 (C_j) as explained above.
 1. In the column labeled 'contribution unit quantity' are listed the values of basic variables included in the solution. We have seen in the initial solution $S_1 = 600$, $S_2 = 650$ and $S_3 = 300$. These values are listed under this column on the right side as shown in table 3.5. Any variables not listed under the solution-mix column are the non-basic variables and their values are zero.
 2. The total profit contribution can be calculated by multiplying the entries in column C_j and column 'contribution per unit quantity' and adding them up. The total profit contribution in the present case is $600 \times 0 + 650 \times 0 + 300 \times 0 = 0$
 3. Numbers under X_1 and X_2 are the physical ratio of substitution. For example, number 2 under X_1 , gives the ratio of substitution between X_1 and S_1 . In simple words if we wish to produce 2 units of product P_1 i.e., X_1 , 2 units of S_1 must be sacrificed. Other numbers have similar interpretation. Similarly, the number in the identity matrix' columns S_1 , S_2 and S_3 can be interpreted as ratios of exchange. Hence the numbers under the columns S_1 , represents the ratio of exchange between S_1 and the basic variables S_1 , S_2 and S_3 .
 4. Z_j and $C_j - Z_j$ are the two final rows. These two rows provide us the total profit and help us in finding out whether the solution is optimal or not. Z_j and $C_j - Z_j$ can be found out in the following manner.
 - (a) $Z_j = C_j$ of S_1 (0) \times coefficient of X_1 in S_1 row (2) + C_j of S_2 (0) \times coefficients of X_1 in S_2 row (1) + C_j of S_3 (0) \times coefficient X_1 in S_3 row (1) = $0 \times 2 + 0 \times 1 + 0 \times 1 = 0$

Table5

C_j	Solution mix	8	12	0	0	0	Contribution unit quantity (Solution values)
		X_1	X_2	S_1	S_2	S_3	
0	S_1	2	1	1	0	0	600
0	S_2	1	2	0	1	0	650
0	S_3	1	0	0	0	1	300
	C_j	0	0	0	0	0	
	$(C_j - C_j)$	8	12	0	0	0	

Using the same procedure Z_j for all the other variable columns can be worked out as shown in the complete first Simplex Table given in Table 5.

- (b) The number in the $(C_j - Z_j)$ row represent the net profit that will result from introducing 1 unit of each product or variable into the solution. This can be worked out by subtracting Z_j total for each column from the C_j values at the top of that variable's column. For example, $C_j - Z_j$ number in the X_1 column will $8 - 0 = 8$, in the X_2 column it will be $12 - 0 = 12$ etc.
- (7) The value of the objective function can be obtained by multiplying the elements in C_j column with the corresponding elements in the C_j rows i.e. in the present case $Z = 8 \times 0 + 12 \times 0 = 0$

Table 6

C_j	Solution mix	8	12	0	0	0	Contribution unit quantity (Solution values)
		X_1	X_2	S_1	S_2	S_3	
0	S_1	2	1	1	0	0	600
0	S_2	1	2	0	1	0	650
0	S_3	1	0	0	0	1	300
	C_j	0	0	0	0	0	
	$(C_j - C_j)$	8	12	0	0	0	

- (8) By examining the number in the $(C_j - Z_j)$ row, we can see that total profit can be increased by #8 for each unit of product X_1 added to the product mix or by #12 for each unit of product X_2 added to the product mix. A positive $(C_j - Z_j)$ indicates that profits can still be improved. A negative number of $(C_j - Z_j)$ would indicate the amount by which the profits would decrease, if one unit of the variable was added to the solution. Hence, optimal solution is reached only when there are no positive numbers in $(C_j - Z_j)$ row.

Step 5. Test for optimality

Now we must test whether the results obtained are optimal or it is possible to carry out any improvements. It can be done in the following manner.

5. Selecting the entering variable. We have to select which of the variables, out of the two non-basic variables X_1 and X_2 , will enter the solution. We select the one with maximum value of $C_j - Z_j$ variable X_1 has a $(C_j - Z_j)$ value of 8 and X_2 has a $(C_j - Z_j)$ value of 12. Hence, we select variable X_2 as the variable to enter the solution mix and identify the column in which it occurs as the key column with help of a small arrow.

6. Selecting the variable that leaves the solution. As a variable is entering the solution, we have to select a variable which will leave the solution. This can be done as follows:
- (a) Divide each number in the solution value or contribution unit quantity column by corresponding number in the key column i.e. divide 600, 650 and 300 by 1, 2, 0.

Table7

C_i	Solution Mix	8 X_1	12 X_2	0 S_1	0 S_2	0 S_3	Solution values	Minimum ratio
0	S_1	2	1	1	0	0	600	600
0	S_2	1	2	0	1	0	650	325
0	S_3	1	0	0	0	1	300	∞
	Z_j	0	0	0	0	0		
	$(C_j - Z_j)$	8	12	0	0	0		

Key row →

↑
Key column

(b) Select the row with smallest non negative ratio as the row to be replaced, in present example the ratio are

$$S_1 \text{ row, } 600/1 = 600 \text{ unit of } X_2$$

$$S_2 \text{ row, } 650/2 = 325 \text{ units of } X_2$$

$$S_3 \text{ row, } 300/0 = \infty \text{ units of } X_2$$

It is clear that S_2 (with minimum ratio) is the departing variable. This row is called the key row.

(c) The number at the intersection of key row and key column is called is called the key number which is 2 in the present case and is circled in the table.

Step 6. Developing second simplex table

Now we can develop the second simplex table by the following method.

(a) Determine new values for the key row. To revise the key rows, divide the values in the key row (S_2) by value of the element (2) and replace departing variable (S_2) by the entering variable (X_2).

(b) Determine new values for other remaining rows. This is done as follows:
New row = old row number – [Corresponding number in key row] x [corresponding fixed ratio] where fixed ratio = old row number in key column/key number.

Now the new S_1 and S_3 row are

$$\text{Row } S_1 = 600 - 650 \times 1/2 = 275$$

$$2 - 1 \times 1/2 = 1.5$$

$$1 - 2 \times 1/2 = 0$$

$$1 - 0 \times 1/2 = 1$$

$$0 - 1 \times 1/2 = 0$$

$$0 - 0 \times 1/2 = 0$$

$$\text{Row } S_2 = 300 - 650 \times 0/2 = 300$$

$$\begin{aligned}
 1 - 1 \times 0/2 &= 1 \\
 0 - 2 \times 0/2 &= 0 \\
 0 - 0 \times 0/2 &= 0 \\
 0 - 1 \times 0/2 &= 0 \\
 1 - 0 \times 0/2 &= 1
 \end{aligned}$$

Key row S_2 is replaced by X_2 with the following elements

$$1/2, 1, 0, 1/2, 0, 325$$

(c) Value of C_j and $C_j - Z_j$ rows can be calculated as explained earlier. The new revised and improved solution table is shown below.

Table8 Second simplex Table

C_i	Solution Mix	8	12	0	0	0	Solution values	Minimum ratio
		X_1	X_2	S_1	S_2	S_3		
0	S_1	1.5	0	1	0	0	275	∞
0	X_2	1/2	1	0	1/2	0	325	325
0	S_3	1	0	0	0	1	300	∞
	Z_j	10	0	0	0	0		
	$(C_j - Z_j)$	0	12	0	0	0		

Key row →

↑
Key column

$$Z_j \text{ values are } Z = 0 \times 1.5 + 0 \times \frac{1}{2} \times 0 \times 1 = 0 \text{ etc.}$$

Minimum ratios by dividing 275, 325 and 300 by corresponding element in the key column i.e., 0, 1, 0.

$$\begin{aligned}
 \frac{275}{0} &= \infty \\
 \frac{325}{1} &= 325 \\
 \frac{300}{0} &= \infty
 \end{aligned}$$

We find that the value of objective function has been improved from 0 to ∞ . But the correct solution is not optimal as there are positive values (12) and (8) in the $(C_j - Z_j)$ row. Also, since minimum ratio is 325, we select X_2 row to leave the solution as X_2 (key column) will enter the solution. The new X_2 (key) row will remain same as its elements 1/2, 1, 0, 1/2, 0 and 325 have to be divided by key element, i.e. (shown circled in the above table). However, row S_1 and S_3 elements will undergo change
 Row $S_1 =$ old row number - [corresponding number in key row] x [corresponding fixed ratio]

Fixed ratio = old row number in key column/ key number = 0

It can be concluded that this problem does not have an optimal solution as X_2 row is to be replaced by X_2 row.

Example 3 ABC Ltd produces four products P_1 , P_2 , P_3 and P_4 . Each one of these products has to be processed on three machines X, Y, Z. The capacity of the machines and the time required to manufacture one of each type of products are shown in the table below:

Product	Processing time for production		
	Machine X	Machine Y	Machine Z
P_1	2	4	3
P_2	3	2	2
P_3	4	1	2
P_4	3	1	1
Capacity (hours)	800	600	420

The profit contribution / unit of products P_1 , P_2 , P_3 and P_4 are Rs. 8, 8, 6, 4, 2 respectively.

You are required to formulate the above as a LPP and determine the optimal product mix by using simplex method.

Solution.

Let x_1 , x_2 , x_3 and x_4 be the number of units of product P_1 , P_2 , P_3 and P_4 respectively.

The mathematical model is as follows :

Maximise $Z = 8x_1 + 6x_2 + 4x_3 + 2x_4$.

Subject to the following constraints

$$2x_1 + 3x_2 + 4x_3 + 3x_4 \leq 800 \text{ (capacity of machine X)}$$

$$4x_1 + 2x_2 + 1x_3 + 2x_4 \leq 600 \text{ (capacity of machine Y)}$$

$$3x_1 + x_2 + 2x_3 + x_4 \leq 420 \text{ (capacity of machine Z)}$$

$$x_1, x_2, x_3, x_4 \geq 0$$

After introducing slack variables S_1 , S_2 and S_3 the problem can be rewritten as

Maximize $Z = 8x_1 + 6x_2 + 4x_3 + 2x_4 + 0S_1 + 0S_2 + 0S_3$

Subject to the constraints

$$2x_1 + 3x_2 + 4x_3 + 3x_4 + S_1 = 800$$

$$4x_1 + 2x_2 + 1x_3 + 2x_4 + S_2 = 600$$

$$3x_1 + x_2 + 2x_3 + x_4 + S_3 = 420$$

$$x_1, x_2, x_3, x_4, S_1, S_2, S_3 \geq 0$$

Initial feasible solution can be obtained by putting the first simplex table can be constructed.

Table 9

C_j	Solution mix	8	6	4	2	0	0	0	Solution Value	Minimum Ratio
		x_1	x_2	x_3	x_4	S_1	S_2	S_3		
0	S_1	2	3	4	3	1	0	0	800	400
0	S_2	4	2	1	2	0	1	0	600	150
0	S_3	3	1	2	1	0	0	1	420	140 → Key row
Z_j		0	0	0	0	0	0	0		
$(C_j - Z_j)$		8	6	4	2	0	0	0		

↑
Key column

x_1 is the key column

S_3 is the key row.

and 3 is the key number (circled in the table)

Also x_1 is the entering variable and S_3 is the outgoing variable.

We use the following row operations to get second simplex table by entering x_1 in to the solution and removing S_3 variable. R_3 (old)

$$R_3 \text{ (new)} = \frac{1}{3}$$

$$R_1 \text{ (new)} = R_1 \text{ (old)} - 3R_3 \text{ (new)}$$

$$R_2 \text{ (new)} = R_2 \text{ (old)} - 2R_3 \text{ (new)}$$

Table 10 Second simplex table

C_j	Solution mix	8	6	4	2	0	0	0	Solution Value	Minimum Ratio
		x_1	x_2	x_3	x_4	S_1	S_2	S_3		
0	S_1	-1	3	2	2	1	0	-1	380	126.7
0	S_2	2	$\frac{4}{3}$	$-\frac{1}{3}$	$\frac{4}{3}$	0	1	$-\frac{2}{3}$	320	240
8	x_1	1	$\frac{1}{3}$	$\frac{2}{3}$	$\frac{1}{3}$	0	0	$\frac{1}{3}$	140	46.7 → Key row
Z_j		8	$\frac{8}{3}$	$\frac{16}{3}$	$\frac{8}{3}$	0	0	$\frac{8}{3}$		
$(C_j - Z_j)$		0	$\frac{10}{3}$	$-\frac{4}{3}$	$-\frac{2}{3}$	0	0	$-\frac{8}{3}$		

↑
Key column

$$R_3(\text{new}) = \frac{1}{3} \times 3 = 1, \frac{1}{3} \times 1 = \frac{1}{3}, \frac{1}{3} \times 2 = \frac{2}{3}, \frac{1}{3}, 0, 0, \frac{1}{3}, 140$$

$$\text{i.e., } 1, \frac{1}{3}, \frac{2}{3}, \frac{1}{3}, 0, 0, \frac{1}{3}, 140$$

$$R_1(\text{new}) = 2 - 3 \times 1 = -1, 3 - 3 \times \frac{1}{3} = 2, 4 - 3 \times \frac{2}{3} = 2, 3 - 3 \times \frac{1}{3} = 2$$

$$1 - 3 \times 0 = 1, 0 - 3 \times 0 = 0, 0 - 3 \times \frac{1}{3} = -1, 800 - 3 \times 140 = 380$$

$$\text{i.e., } 1, 2, 2, 2, 1, 0, -1, 380.$$

$$R_2(\text{new}) = 4 - 2 \times 1 = 2, 2 - 2 \times \frac{1}{3} = \frac{4}{3}, 1 - 2 \times \frac{2}{3} = -\frac{1}{3}, 2 - 2 \times \frac{1}{3} = \frac{4}{3}$$

$$0 - 2 \times 0 = 0, 1 - 2 \times 0 = 1, 0 - 2 \times \frac{1}{3} = -\frac{2}{3}, 600 - 2 \times 140 = 320$$

$$\text{i.e., } 2, \frac{4}{3}, -\frac{1}{3}, \frac{4}{3}, 0, 1, -\frac{2}{3}, 320$$

Calculation of Z_j

$$Z_j(x_1) = -1 \times 0 + 2 \times 0 + 1 \times 8 = 8$$

$$Z_j(x_2) = 2 \times 0 + \frac{4}{3} \times 0 + \frac{1}{3} \times 8 = \frac{8}{3}$$

$$Z_j(x_3) = \frac{16}{3}$$

$$Z_j(x_4) = \frac{8}{3} \quad Z_j = 380 \times 0 + 320 \times 0 + 140 \times 8 = 1120$$

$$Z_j(S_1) = 0$$

$$Z_j(S_2) = 0$$

$$Z_j(S_3) = \frac{8}{3}$$

It can be seen that Z has improved from 0 to 1120 but since there is still a positive value in $(C_j - Z_j)$ it is not optimal solution.

It is now clear that x_2 is the entering variable and x_1 the departing variable.

Now the third simplex table is to be constructed

We now use the following row operations to get a new solution by entering x_2 and removing x_1 variable.

$$R_1(\text{new}) = R_1(\text{old})$$

$$R_2(\text{new}) = R_2(\text{old}) - \frac{2}{3} R_1(\text{new})$$

$$R_3(\text{new}) = R_3(\text{old}) - \frac{2}{3} R_1(\text{new})$$

$$R_1(\text{new}) = -1, 2, 2, 2, 1, 0, -1, 380$$

$$R_2(\text{new}) = 2 - \frac{2}{3} \times -1 = \frac{8}{3}, \frac{4}{3} - \frac{2}{3} \times 2 = 0, -\frac{1}{3} - \frac{2}{3} \times 2 =$$

$$\frac{4}{3} - \frac{2}{3} \times 2 = 0, 0 - \frac{2}{3} \times 1 = \frac{-2}{3}, \times 1 = \frac{-2}{3}, 0 - \frac{2}{3} \times 0 = 0$$

$$\frac{1}{3} - \frac{2}{3} \times -1 = 1, 320 - \frac{2}{3} \times 380 = \frac{200}{3}$$

$$i.e., \quad \frac{8}{3}, 0, \frac{-5}{3}, 0, \frac{-2}{3}, 0, 1, \frac{200}{3}$$

$$R_3(\text{new}) = 1 - \frac{2}{3} \times -1 = \frac{5}{3}, \frac{1}{3} - \frac{2}{3} \times 2 = -1, \frac{2}{3} - \frac{2}{3} \times 2 = \frac{-2}{3}$$

$$\frac{1}{3} - \frac{2}{3} \times 2 = -1, 0 - \frac{2}{3} \times 1 = \frac{-2}{3}, 0 - \frac{2}{3} \times 0 = 0$$

$$\frac{1}{3} - \frac{2}{3} \times -1 = 1, 140 - \frac{2}{3} \times 380 = \frac{-340}{3}$$

$$i.e., \quad \frac{5}{3}, -1, \frac{-2}{3}, -1, \frac{-2}{3}, 0, 1, \frac{-340}{3}$$

Table 11 Third simplex table

C_j	Solution mix	8	6	4	2	0	0	0	Solution mix
		x_1	x_2	x_3	x_4	S_1	S_2	S_3	
0	S_1	-1	2	2	2	1	0	-1	380
0	S_2	$\frac{8}{3}$	0	$\frac{-5}{3}$	0	$\frac{-2}{3}$	0	1	$\frac{200}{3}$
6	x_2	$\frac{5}{3}$	-1	$\frac{-2}{3}$	-1	$\frac{-2}{3}$	0	1	$\frac{-340}{3}$
Z_j		10	-6	$\frac{-12}{3}$	-6	-4	0	6	
$(C_j - Z_j)$		-2	0	8	8	4	0	-6	

The student should further attempt this problem to get the optimal solution. The present solution is not the optimal solution as positive values exist in $C_j - Z_j$

3.2 MINIMISATION PROBLEMS (ALL CONSTRAINTS OF THE TYPE \geq) BIG ‘M’ METHOD

We have till now seen in this chapter, the type of problems where profit had to be maximized and the constraints were of the type \leq . However, there could be problems where the objective function has to be minimized (like the availability of funds, raw material or the costs of operations have to be minimized) and the constraints involved may be of the type $>$ or $=$. In such cases, the simplex method is somewhat different and is discussed in the form of following steps.

Step I. Formulation of mathematical model

$$\text{Minimise } Z = C_1 x_1 + C_2 x_2 + C_3 x_3 + \dots + C_n x_n$$

Subject to the constraints

$$a_{11} x_1 + a_{12} x_2 + a_{13} x_3 + \dots + a_{1n} x_n \geq b_1$$

$$a_{21} x_1 + a_{22} x_2 + a_{23} x_3 + \dots + a_{2n} x_n \geq b_2$$

$$\vdots \qquad \qquad \qquad \vdots \qquad \qquad \qquad \vdots \qquad \qquad \qquad \vdots \qquad \qquad \qquad \vdots$$

$$a_{m1} x_1 + a_{m2} x_2 + a_{m3} x_3 + \dots + a_{mn} x_n \geq b_m$$

where $x_1, x_2, x_3, \dots, x_n \geq 0$

Now we subtract the surplus variables S_1, S_2, \dots, S_n etc to convert the inequalities into equations.

$$\text{i.e., Minimise } Z = C_1 x_1 + C_2 x_2 + C_3 x_3 + \dots + C_n x_n + 0S_1 + 0S_2 + \dots + 0S_n$$

Subject to the constraints

$$a_{11} x_1 + a_{12} x_2 + a_{13} x_3 + \dots + a_{1n} x_n - S_1 = b_1$$

$$a_{21} x_1 + a_{22} x_2 + a_{23} x_3 + \dots + a_{2n} x_n - S_2 = b_2$$

$$\vdots \qquad \qquad \qquad \vdots \qquad \qquad \qquad \vdots \qquad \qquad \qquad \vdots$$

$$a_{m1} x_1 + a_{m2} x_2 + a_{m3} x_3 + \dots + a_{mn} x_n - S_m = b_m$$

where $x_i > 0$ ($i = 1, 2, \dots, n$)

$$S_j > 0$$
 ($j = 1, 2, \dots, m$)

As in the maximization problem, initial basic solution is obtained by putting $x_1 = x_2 = \dots = x_n = 0$

$$\begin{array}{ll} \text{So} & - S_1 = b_1 \quad \text{or} \quad S_1 = - b_1 \\ & - S_2 = b_2 \quad \text{or} \quad S_2 = - b_2 \\ & \vdots \qquad \qquad \qquad \vdots \qquad \qquad \qquad \vdots \\ & - S_m = b_m \quad \text{or} \quad S_m = - b_m \end{array}$$

It may be seen that S_1, S_2, \dots, S_m being negative violate the non-negativity constraint and hence is not feasible. Hence, in the system of constraints we introduce m new variables A_1, A_2, \dots, A_m known as artificial variable. By introducing these variables the equations are

$$\begin{array}{cccccccc}
a_{11} x_1 + a_{12} x_2 + a_{13} x_3 + \dots & a_{1n} x_n - S_1 + A_1 & = & b_1 & & & & \\
a_{21} x_1 + a_{22} x_2 + a_{23} x_3 + \dots & a_{2n} x_n - S_2 + A_2 & = & b_2 & & & & \\
\vdots & \vdots & & \vdots & & & & \\
a_{m1} x_1 + a_{m2} x_2 + a_{m3} x_3 + \dots & a_{mn} x_n - S_m + A_m & = & b_m & & & &
\end{array}$$

where $x_j > 0$ ($i = 1, 2, 3, \dots, n$)

$$S_j > 0 \quad (j = 1, 2, 3, \dots, m)$$

$$A_j > 0 \quad (j = 1, 2, 3, \dots, m)$$

As we have introduced artificial variables A_1, A_2, \dots, A_m this has to be taken out of the solution. For this purpose, we introduce a very large value (M) assigned to each of artificial variable and zero to each of the surplus variables as the coefficient values in the objectives function. The problem now become

$$\begin{aligned}
\text{Minimise } Z = & C_1 x_1 + C_2 x_2 + C_3 x_3 + \dots + C_n x_n \\
& + 0S_1 + 0S_2 + \dots + 0S_m + \\
& MA_1 + MA_2 + \dots + MA_m
\end{aligned}$$

Subject to constraints

$$\begin{array}{cccccccc}
a_{11} x_1 + a_{12} x_2 + a_{13} x_3 + \dots & a_{1n} x_n - S_1 + A_1 & = & b_1 & & & & \\
a_{21} x_1 + a_{22} x_2 + a_{23} x_3 + \dots & a_{2n} x_n - S_2 + A_2 & = & b_2 & & & & \\
\vdots & \vdots & & \vdots & & & & \\
\vdots & \vdots & & \vdots & & & & \\
a_{m1} x_1 + a_{m2} x_2 + a_{m3} x_3 + \dots & a_{mn} x_n - S_m + A_m & = & b_m & & & &
\end{array}$$

Step 2. Setting up of initial simplex table

Here, we allot 0 values to variables $x_1 = x_2 = x_3 \dots = x_n = 0$ so that $A_1 = b_1, A_2 = b_2, \dots, A_m = b_m$.

Table 12 Initial simplex table

		C_j	C_1	C_2	C_3	\dots	C_n	0	0	M	\dots	M	Minimum ratio
CB	Solution mix	Solution values	x_1	x_2	x_3	\dots	x_n	S_1	S_2	S_m	A_1		
CB ₁	A ₁	b ₁	a_{11}	a_{12}	\dots		a_{1n}	-1	0	0	1	\dots	

CB ₂	A ₂	b ₂	0	
⋮	⋮	⋮	a ₂₁ a ₂₂ a _{2n} 0 -1 0 0 1	
CB _n	A _m	B _m	0	
			⋮	
			⋮	
			A _{m1} a _{m2} a _{mn} 0 0 -1 0 0	
			I	
Z _j			0 0 0 0 0 0 0 0	
(C _j - Z _j)			0	
			C ₁ C ₂ C _n 0 0 0 M M	
			M	

Step 3. Test for optimality

Calculate the elements of (C_j - Z_j) row

- (a) If all (C_j - Z_j) > 0 then the basic feasible solution is optimal.
- (b) If any one (C_j - Z_j) < 0 then pick up the largest negative number in this row.
This is the key column and determines the variable entering the solution.

Now the second simplex table can be constructed.

Step 4. Test for feasibility

Determine the key row and key number (element) in the same manner as is done in the maximization problem.

Example 4 A special diet for a patient in the hospital must have at least 8000 units of vitamins, 100 units of minerals and 2800 units of calories. Two types of foods X and Y are available in the market at the cost of #8 and #6 respectively. One unit of X contains 40 units of vitamins, 2 units of minerals and 80 units of calories. One unit of food B contains 200 units of vitamins, 4 units of minerals and 80 units of calories. What combination of foods X and Y be used so that the minimum requirement of vitamins, minerals and calories is maintained and the cost incurred by the hospital is minimized? Use simplex method.

Sol. Mathematical model of the problem is as follows

$$\text{Minimize } Z = 8x_1 + 6x_2$$

Subject to the constraints

$$400x_1 + 200x_2 \geq 800 \text{ (Constraint of minimum vitamins)}$$

$$2x_1 + 4x_2 \geq 100 \text{ (Constraint of minimum minerals)}$$

$$80x_1 + 80x_2 \geq 2800 \text{ (Constraint of minimum calories)}$$

$$x_1, x_2 \geq 0 \text{ (Non - negativity constraint)}$$

where x_1 and x_2 are the number of units of food X and food Y. Now the constraint inequalities can be converted into equations. Here, we take an initial solution with very high cost, as opposed to the maximum problem where we had started with an initial solution with no profit. We subtract surplus variables S_1 , S_2 and S_3 .

$$400x_1 + 200x_2 - S_1 = 800$$

$$2x_1 + 4x_2 - S_2 = 100$$

$$80x_1 + 80x_2 - S_3 = 2800$$

The surplus variables S_1 , S_2 and S_3 introduced in these equations represent the extra unit of vitamins, minerals and calories over 8000 units, 100 units and 2800 units in the least cost combinations.

Let x_1 , x_2 be zero in the initial solution

Hence $S_1 = -8000$

$$S_2 = -100$$

$$S_3 = -2800$$

This is not feasible as S_1 , S_2 and $S_3 \geq 0$ and cannot be negative. We have to see that S_1 , S_2 and S_3 do not appear (as they are -ve) in the initial solution. So is x_1 , x_2 and S_1 , S_2 , S_3 are all zero, new foods which can substitute food X and Y must be introduced.

A_1 , A_2 and A_3 are the artificial variables to be introduced. Let the artificial variables (foods) be of a large price, M per unit

$$400x_1 + 200x_2 - S_1 + A_1 = 8000$$

$$2x_1 + 4x_2 - S_2 + A_2 = 100$$

$$80x_1 + 80x_2 - S_3 + A_3 = 2800$$

And Z object function

$$\text{Minimise } Z = 8x_1 + 6x_2 + 0S_1 + 0S_2 + 0S_3 + MA_1 + MA_2 + MA_3$$

where x_1

$$x_2, S_1, S_2, S_3, A_1, A_2, A_3 \geq 0$$

Now, it is possible to set up initial solution by putting $x_1 = x_2 = S_1 = S_2 = S_3 = 0$ in such a manner that $A_1 = 8000$, $A_2 = 100$ and $A_3 = 2800$.

Table 13
First simplex table

		C_j	8	6	0	0	0	M	M	M	
C_B	B Solution mix variable	$b(=x_B)$ Solution values	x_1	x_2	S_1	S_2	S_3	A_1	A_2	A_3	Min ratio
M	A_1	8000	400	200	-1	0	0	1	0	0	20
M	A_2	100	2	4	0	-1	0	0	1	0	50
M	A_3	2800	80	80	0	0	-1	0	0	1	35
Z_j			482M	284 M	-M	-M	-M	M	M	M	
$(C_j - Z_j)$			8 - 482M	6 - 284M	M	M	M	0	0	0	

Key column

x_1 is the key column entering the solution, A_1 is the departing row and 400 (circled) in the table is the key number (element).

Now apply the row operations

$$(i) \quad R - 1 \text{ (new)} \rightarrow \frac{1}{400} R - 1 \text{ (old)}$$

$$(ii) \quad R - 2 \text{ (new)} \rightarrow R - 2 \text{ (old)} - 2R - 1 \text{ (new)}$$

$$(iii) \quad R - 3 \text{ (new)} \rightarrow R - 3 \text{ (old)} - 80 R - 1 \text{ (new)}$$

Table 14 second simplex table

		C_j	8	6	0	0	0	M	M	M	
C_B	Solution mix variable (= B)	Solution values $b(=x_B)$	x_1	x_2	S_1	S_2	S_3	A_1	A_2	A_3	Min ratio
8	x_1	20	1	$\frac{1}{2}$	$-\frac{1}{400}$	0	0		0	0	40
M	A_2	60	0	3	$\frac{1}{200}$	-1	0		1	0	20
M	A_2	1200	0	40	$\frac{1}{5}$	0	-1		0	1	30
Z_j			8	4+43M	$-\frac{4+41M}{200}$	-M	-M		M	M	
$(C_j - Z_j)$			0	2 - 43M	$\frac{4 - 41M}{200}$	M	M		0	0	

Key column

Value of Z calculated as follows

$$Z_j(x_1) = 8 \times 1 + M \times 0 = 8$$

$$Z_j(x_2) = \frac{1}{2} \times 8 + 3 \times M + 40M = 4 + 43M$$

$$Z_j(S_1) = \frac{1}{400} \times 8 + \frac{1}{200} M + \frac{1}{5} M = \frac{-4 + 41M}{200}$$

$$Z_j(S_2) = -M$$

$$Z_j(S_3) = -M$$

$$Z_j(A_2) = M$$

$$Z_j(A_3) = M$$

It is clear from the above table, that x_2 enters the solution and A_2 departs, using the following row operations, we introduce x_2 and remove A_2 .

$$(i) R - Z \text{ (new)} \rightarrow \frac{1}{3} R - 2 \text{ (old)}$$

$$(ii) R - 1 \text{ (new)} \rightarrow R - 1 \text{ (old)} - \frac{1}{2} R - 2 \text{ (new)}$$

$$(iii) R - 3 \text{ (new)} \rightarrow R - 3 \text{ (old)} - 40 R - 1 \text{ (new)}$$

$$R - 2 \text{ (new)} = 20, 0, 1, \frac{1}{600}, -\frac{1}{3}, 0, \frac{1}{3}, 0.$$

$$R - 1 \text{ (new)} = 10, 1, 0, -\frac{1}{300}, \frac{1}{6}, 0.$$

$$R - 3 \text{ (new)} = 400, 0, 0, \frac{2}{15}, \frac{40}{3}, -1.$$

Table 15 second simplex table

		C_j	8	6	0	0	0	M	M	M	
C_B	Solution mix variable (= B)	Solution values b(= x_B)	x_1	x_2	S_1	S_2	S_3	A_1	A_2	A_3	Min ratio
8	X_1	10	1	0	$-\frac{1}{300}$	$\frac{1}{6}$	0	-	-	0	60
6	X_2	20	0	1	$\frac{1}{600}$	$-\frac{1}{3}$	0	-	-	0	-60
M	A_3	400	0	0	$\frac{2}{5}$	$\frac{40}{3}$	-1	-	-	1	30
Z_j			8	6	$\frac{-1+8M}{60}$	$\frac{-2+4M}{3}$	-M	-	-	M	
$(C_j - Z_j)$			0	2 - 43M	$\frac{1-8M}{60}$	$\frac{2-4M}{3}$	M	-	-	0	

It can be seen S_2 has to be introduced and A_3 has to depart. This procedure can be adopted for further improving the solution by constructing fourth simplex table and so on.

3.3 MINIMISING CASE – CONSTRAINTS OF MIXED TYPES (\leq AND \geq)

We have seen the examples earlier where the constraints were either $>$ type or $<$ type. Both there are problems where the constraint equation could contain both types of constraints. This type of problem is illustrated with the help of an example.

Example 4

A metal alloy used in manufacture of rifles uses two ingredients A and B. A total of 120 units of alloy is used for production. Not more than 60 units of A can be used and at least 40 units of ingredient B must be used in the alloy. Ingredient A costs Rs. 4 per unit and ingredient B costs Rs. 6 per unit. The company manufacturing rifles is keen to minimize its costs. Determine how much of A and B should be used.

Sol. Mathematical formulation of the problem is

Minimise cost $Z = 4x_1 + 6x_2$

Subject to constraints.

$x_1 + x_2 = 120$ (Total units of alloy)

$x_1 \leq 60$ (Ingradient A constraint)

$x_2 \leq 40$ (Ingradient B constraint)

$x_1, x_2 \geq 0$ (Non-negativity constraint)

where x_1 and x_2 number of units of ingredient A and B respectively. Let x_1 and $x_2 = 0$ and let us introduce an artificial variable which represents a new ingredient with very high cost M .

$x_1 + x_2 + A_1 = 120$

Also $x_1 + S_1 = 60$

Third constraint $x_2 - S_2 + A_2 = 40$

Now the standard form of the problem is

Minimize $Z = 4x_1 + 6x_2 + MA_1 + 0S_1 + 0S_2 + MA_2$

Subject to the constraints

$x_1 + x_2 + A_1 = 120$

$x_1 + S_1 = 60$

$x_2 - S_2 + A_2 = 40$

$x_1, x_2, S_1, S_2, A_1, A_2 \geq 0$

Initial basic solution is obtained by putting $x_1 = x_2 = 0$ and $S_1 = S_2 = 0$ so that $A_1 = 120, S_1 = 60, A_2 = 40$

Table 16 First simplex table

C_B	Solution mix	Solution values	C_j	4	6	M	0	0	M	Minimum ratio
				x_1	x_2	A_1	S_1	S_2	A_2	
M	A_1	120		1	1	1	0	0	0	120
0	S_1	60		1	0	0	1	0	0	-
M	A_2	40		0	Ⓐ	0	0	-1	0	40 $\xrightarrow{\text{Key}}$ row
Z_j				M	2M	M	0	-M	M	
$(C_j - Z_j)$				4 - M	6 - 2M	0	0	M	0	

6 - 2M is the largest negative number hence, x_2 will enter the solution and since 40 is the minimum ratio A_1 will depart.

R - 3 (New) \rightarrow R - 3 (old) as key element is 1

R - 1 (New) \rightarrow R - 1 (old) - R - 3 (New)

Table 17 Second simplex table

C_B	Solution mix	Solution values	C_j	4	6	M	0	0	M	Minimum ratio
				x_1	x_2	A_1	S_1	S_2	A_2	

M	A ₁	80	1	0	1	0	1		80
0	S ₁	60	⊕	0	0	1	0		60 →
6	X ₂	40	0	1	0	0	-1		-
Z _j			M	6	M	0	M-6		
(C _j - Z _j)			4 - M	0	0	0	-M + 6		

Key column

$$R - 1 \text{ (new)} = 1 - 0 = 1; 1 - 1 = 0, 1 - 0 = 1, 0 - 0 = 0, 0 - (-1) = 1$$

$$\text{i.e., } 0, 1, 1, 0, 1, 100 - 40 = 60$$

x_1 will be introduced and S_1 will depart

Use the following row operations

(i) $R - 2 \text{ (new)} \rightarrow R_2 \text{ (old)}$

(ii) $R - 1 \text{ (new)} \rightarrow R_1 \text{ (old)} - R_2 \text{ (new)}$

$$R - 2 \text{ (new)} = 1, 0, 0, 1, 0$$

$$R - 1 \text{ (new)} = 1 - 1 = 0, 0 - 0 = 0, 1 - 0 = 1, 0 - 1 = -1, 1 - 0 = 1$$

Table 18 Third simplex table

C _B	Solution mix	Solution values	C _j					Minimum ratio
			4	6	M	0	0	
M	A ₁	40	0	0	1	-1	⊕	40
4	x_1	60	1	0	0	1	0	-
6	X ₂	40	0	1	0	0	-1	-40
Z _j			4	6	M	-M+4	M-6	
(C _j - Z _j)			0	0	0	M-4	-M+6	

Key column

We now introduce S_2 and take out A_1 using following row operations

$$R - 1 \text{ (new)} \rightarrow R - 1 \text{ (old)}$$

$$R - 3 \text{ (new)} \rightarrow R - 3 \text{ (old)} + R - 1 \text{ (new)}$$

Table 19 Forth simplex table

C _B	Solution mix	Solution values	C _j					
			4	6	M	0	0	M
0	S ₂	40	0	0		-1	1	
4	x_1	60	1	0		1	0	
6	x_2	80	0	1		-1	0	
Z _j			4	6	-	-2	0	
(C _j - Z _j)			0	0	-	2	0	

Since all the numbers in $(C_j - Z_j)$ are either zero or positive, this is the optimal solution.

$$x_1 = 60, x_2 = 80 \text{ and } Z = 40 \times 60 + 6 \times 80 = \#720$$

3.4 Maximisation case-constraints of mixed type

A problem involving mixed type of constraints in which $=$, \geq and \leq are involved and the objective function is to be maximized.

Example 6. Maximise $Z = 2x_1 + 4x_2 - 3x_3$

Subject to the constraints.

$$x_1 + x_2 + x_3 \geq 8$$

$$x_1 - x_2 \geq 1$$

$$3x_1 + 4x_2 + x_3 \geq 40$$

Sol. The problem can be formulated in the standard form

$$\text{Maximise } Z = 2x_1 + 4x_2 - 3x_3 + 0S_1 - MA_1 - MA_2$$

Subject to constraints

$$x_1 + x_2 + x_3 + A_1 = 8$$

$$x_1 - x_2 - S_1 + A_2 = 1$$

$$3x_1 + 4x_2 + x_3 + S_3 = 40$$

$$x_1 \geq 0, x_2 \geq 0, S_1 \geq 0, S_2 \geq 0, A_1 \geq 0, A_2 \geq 0.$$

Where A_1 and A_2 are the artificial constraints, S_1 is the surplus variable, S_2 is the slack variable and M is a very large quantity. For initial basic solution: $A_1 = 8, A_2 = 1, S_2 = 40$

Table 20 First simplex table

C_B	Solution mix variable (B)	C_j Solution values $b (=x_B)$	2	4	-3	0	0	-M	-M	Minimum ratio
			x_1	x_2	x_3	S_1	S_2	A_1	A_2	
-M	A_1	8	1	1	1	0	0	1	0	8
-M	A_2	1	1	-1	0	-1	0	0	1	1
0	C_2	40	3	4	1	0	1	0	0	$\frac{40}{3}$
Z_j			-2M	0	-M	M	0	-M	-M	
$(C_j - Z_j)$			2+2M	4	-3+M	-M	0	0	0	

Key column

This is a problem of maximization, hence we select $2 + 2M$, the largest positive number in $(C_j - Z_j)$ x_1 will enter and A_2 will depart. Use the following row operations.

$$R - 2 \text{ (new)} \rightarrow R - 2 \text{ (old)}$$

$$R - 1 \text{ (new)} \rightarrow R - 1 \text{ (old)} - R_2 \text{ (new)}$$

$$R - 3 \text{ (new)} \rightarrow R - 3 \text{ (old)} - 3 R_2 \text{ (new)}$$

Table 21 Second simplex table

C_B	Solution mix variable (B)	C_j Solution values $b (=x_B)$	2	4	-3	0	0	-M	-M	Minimum ratio
			x_1	x_2	x_3	S_1	S_2	A_1	A_2	
-M	A_1	7	0	2	1	1	0		-1	$\frac{7}{2} \rightarrow$
2	x_2	1	1	-1	0	-1	0		1	-1
0	S_2	37	0	7	0	3	1		-3	$\frac{37}{7}$
Z_j			2	-2M-2	-M	-M-2	0		M+2	
$(C_j - Z_j)$			0	6+2M	-3+M	M+2	0		-2	

Key column

$$\begin{aligned}
R - 2 \text{ (new)} &= R - 2 \text{ (old)} \\
R - 1 \text{ (new)} &= R - 1 \text{ (old)} - R - 2 \text{ (new)} \\
R - 3 \text{ (new)} &= 40 - 3 \times 1 = 37, 3 - 3 \times 1 = 0, 4 - 3 \times 1 = 7 \\
&0 - 3 \times 0 = 0, 0 - 3 \times -1 = 3, 1 - 3 \times 0 = 1, 0 - 3 \times 1 =
\end{aligned}$$

- 3

Now x_2 will enter as new variable and A_1 will depart as shown. Third simplex table can be prepared by using the following row operations.

$$\begin{aligned}
R - 1 \text{ (new)} &= \frac{1}{2} R - 1 \text{ (old)} \\
R - 2 \text{ (new)} &= R - 2 \text{ (old)} + R - 1 \text{ (new)} \\
R - 3 \text{ (new)} &= R - 3 \text{ (old)} - 7 R - 1 \text{ (new)} \\
R - 1 \text{ (new)} &= \frac{7}{2}, 0, 1, \frac{1}{2}, \frac{1}{2}, 0 \\
R - 2 \text{ (new)} &= \frac{9}{2}, 1, 0, \frac{1}{2}, \frac{-1}{2}, 0 \\
R - 3 \text{ (new)} &= 37 - 7 \times \frac{7}{2} = \frac{25}{2}, 0 - 7 \times 0 = 0, 7 - 7 \times 1 = 0 \\
&0 - 7 \times \frac{1}{2} = \frac{-7}{2}, 3 - 7 \times \frac{1}{2} = \frac{-1}{2}, 1 - 7 \times 0 = 1 \\
&\frac{25}{2}, 0, 0, \frac{-7}{2}, \frac{-1}{2}, 1
\end{aligned}$$

Table 22 Third simplex table

		C_j	2	4	-3	0	0	-M	-M
C_B	Solution mix variable (B)	Solution values $b (=x_B)$	X_1	X_2	x_3	S_1	S_2	A_1	A_2
4	x_1	$\frac{7}{2}$	0	1	$\frac{1}{2}$	$\frac{1}{2}$	0		
2	x_2	$\frac{9}{2}$	1	0	$-\frac{1}{2}$	$-\frac{1}{2}$	0		
0	S_2	$\frac{25}{2}$	0	0	$-\frac{7}{2}$	$-\frac{1}{2}$	1		
Z_j			2	4	3	1	0		
$(C_j - Z_j)$			0	0	-6	-1	0		

Since all the entries in $C_j - Z_j$ are either 0 or negative, optimal solution has been obtained with

$$\begin{aligned}
x_1 &= \frac{9}{2}, x_2 = \frac{7}{2}, x_3 = 0, S_2 = \frac{11}{2} \text{ and } Z = 2x_1 + 4x_2 - 3x_3 + 0S_1 + 0S_2 \\
&= 9 + 14 - 0 + 0 + 0 = \#23.
\end{aligned}$$

4.0. CONCLUSION

As in the summary.

5.0. SUMMARY

1. Simplex methods can be used to solve a linear programming model whose number of decision variable is two or more.
2. In standard linear programming models, for maximization problems. We use the “less than or equal to sign”, while for minimization problem we use the “greater than or equal to sign”
3. In the simplex method, the process of determining the main variable that can be included or the non basic variable that can be excluded is known as “change of Basis”

6.0. TUTOR MARKED ASSIGNMENT

Following data is available for a manufacturing company engaged in production of three item X, Y and Z

Production	Time required in hours		Total Contribution (Rs)
	Marching	Finishing	
X	12	3	1000
Y	6	8	800
Z	8	6	400
Company's capacity	3000	1500	

You are required to present the above data in the form of LLP to maximize the profit from the production and solve the problem using simplex method.

7.0. REFERENCES/FURTHER READINGS

1. Operations Research. By Prem Kumar Gupta and D.S. Hira
2. Operations Research. (Problem Solvers) By Research and Education Association.
9. Statistics and Operations Research. By Debashis Dutta
10. Operations Research By). O.T. Arowolo and G.O. Lawal

UNIT 5 LINEAR PROGRAMMING 3 (DUALITY)

CONTENTS

8.0. Introduction

9.0. Objective

10.0. Main Content

3.1. Dual problems when primal is in standard form

3.2. Formulation of the dual of the primal problem

3.3. INTERPRETING PRIMAL – DUAL OPTIMAL SOLUTIONS

11.0. Conclusion

12.0. Summary

13.0. Tutor Marked Assignment

14.0. Reference/ Further Readings

4.0 INTRODUCTION

Concept of Primal-Dual relationship or duality in Linear Programming.

The original LPP as we have studied is called the Primal. For every LP problem there exists another related unique LP problem involving the same data which also described the original problem. The original or primal programme can be solved by transposing or reversing the rows and columns of the statement of the problem. Reversing the rows and columns in this way gives us the dual program. Solution to dual program problem can be found out in a similar manner as we use for solving he primal problem. Each LP maximizing problem has its corresponding dual, a minimizing problem. Also, each LP minimizing problem has is corresponding dual, a maximizing problem. This duality is an extremely important and interesting feature of Linear Programming Problems (LPP). Important facts of this property are:-

- (a) The optimal solution of the dual gives complete information about the optimal solution of the primal and vice versa.
- (b) Sometimes converting the LPP into dual and then solving it gives many advantages, for example, if the primal problem contains a large number of constraints in the form of rows and comparatively a lesser number of variables in the form of columns, the solution can be considerably simplified by converting the original problem into dual and then solving it.
- (c) Duality can provide us economic information useful to management. Hence it has certain far reaching consequences of economic nature, since it helps managers in decision making
- (d) It provides us information as to how the optimal solution change due to he results of the changes in coefficient and formulation of the problem. His can be used for sensitivity analysis after optimality tests are carried out.
- (e) Duality indicates that there is a fairly close relationship between LP and Games theory as its shows each LPP is equivalent to a two-person zero-sum game.
- (f) Dual of the dual is a primal.

5.0 OBJECTIVE

- * Understand optimal – dual concept
- * Understand dual formulation procedure
- * Interpret dual programming model
- * Solve LP problems using duality

6.0 MAIN CONTENT

3.1 DUAL PROBLEMS WHEN PRIMAL IS IN THE STANDARD FORM

We have already seen the characteristics of the standard form of LPP, let us recall them once again

These are:-

- (a) All constraints are expressed in the form of equation only the non-negativity constraint is expressed as ≥ 0
- (b) The right hand side of each constraint equation is non-negative
- (c) All the decision variables are non-negative
- (d) The objective function Z , is either to be maximized or minimized.

Let us consider a general problem.

The primal problem can be expressed as

$$\text{Maximize } Z = C_1 X_1 + C_2 X_2 + \dots + C_n X_n$$

$$\text{Subject to } a_{11} X_1 + a_{12} X_2 + \dots + a_{1n} X_n \leq b_1$$

$$a_{21} X_1 + a_{22} X_2 + \dots + a_{2n} X_n \leq b_2$$

$$\vdots \qquad \qquad \qquad \vdots \qquad \qquad \qquad \vdots \qquad \qquad \qquad \vdots$$

$$a_{m1} X_1 + a_{m2} X_2 + \dots + a_{mn} X_n \leq b_m$$

$$X_1, X_2, \dots, X_n = 0$$

The dual can be expressed as follows

$$\text{Maximize } Z^* = B_1 Y_1 + B_2 Y_2 + \dots + B_m Y_m$$

$$\text{Subject to } a_{11} Y_1 + a_{12} Y_2 + \dots + a_{m1} Y_m \geq C_1$$

$$a_{12} Y_1 + a_{22} Y_2 + \dots + a_{m2} Y_m \geq C_2$$

$$\vdots \qquad \qquad \qquad \vdots \qquad \qquad \qquad \vdots \qquad \qquad \qquad \vdots$$

$$A_{1n} Y_1 + a_{2n} Y_2 + \dots + a_{mn} Y_m \geq C_m$$

$$Y_1, Y_2, \dots, Y_m = 0$$

Where Y_1, Y_2, \dots, Y_m are the dual decision variables.

In general, standard form of the primal is defined as

$$\text{Maximize or minimize } Z = \sum_{j=1}^n C_j x_j$$

$$\text{Subject to } \sum_{j=1}^n a_{ij} x_j = b_i \qquad i = 1, 2, \dots, m$$

$$X_j \geq 0 \qquad j = 1, 2, \dots, n$$

For constructing a dual of this standard form let us arrange the coefficient of primal as

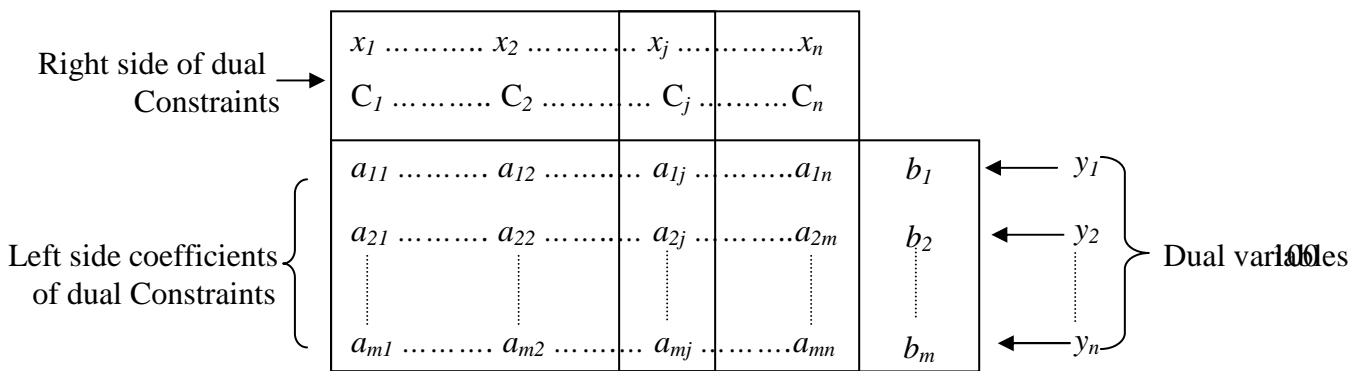

It may be noted that dual is obtained symmetrically from the primal using the following rules.

- i. For every primal constraint, there is a dual variable here $X_1, X_2 \dots \dots \dots X_n$ are the primal constraints and $Y_1, Y_2 \dots \dots \dots Y_n$ are the dual variables.
- ii. For every primal variable, there is a dual constraint $X_1, X_2 \dots \dots \dots X_n$ are the primal variable.
- iii. The constraint coefficient of a primal variable form the left side coefficients of the corresponding dual constraints, and the object coefficient of the same variable becomes the right hand side of the dual constraint as shown in the shaded column

The above rules indicate that the dual problem will have m variables ($Y_1, Y_2 \dots \dots \dots Y_n$) and n constraints ($X_1, X_2 \dots \dots \dots X_n$). The sense of optimization, type of constraints and the sign of dual variables, for the maximization and minimization types of standard form are given below.

Standard Primal			Dual		
Objective	Constraints	Variables	Objective	Constraints	Variables
Maximisation	Equations with Non-negative	All Non negative	Minimisation	$> =$	Unrestricted
Minimisation	RHS		Maximisation	$\leq =$	Unrestricted

3.2 FORMULATION OF THE DUAL OF THE PRIMAL PROBLEM

The parameters and structure of the primal provides all the information necessary to formulate a dual.

The following general observations are useful are useful

- i. The primal is a maximization problem and the dual is a minimizing problem. **The sense of optimization is always opposite for corresponding primal and dual problems.**
- ii. The primal consists of two variable and three constraints and dual consists of three variable and two constrains. **The number of variables in the primal**

always equals the number of constraints in the dual. The number of constraints in the primal always equals the number of variables in the dual.

- iii. The objective function coefficients for x_1 and x_2 in the primal equal the right-hand side constraints for constraints (1) and (2) in the dual. **The objective function coefficient for the j^{th} primal variable equals the right-hand-side constraint for the j^{th} dual constraint.**
- iv. The right-hand-side constraints for constraints (1), (2) and (3) in the primal equal the objective function coefficients for the dual variables y_1 , y_2 and y_3 . **The right-hand-side constraints for the i^{th} primal constraint equals the objective function coefficient for the i^{th} dual variable.**
- v. The variable coefficients for constraint (1) of the primal equal the column coefficients for the dual variable y_1 . The variable coefficients of constraints (2) and (3) of the primal equal the column coefficients of the dual variable y_2 and y_3 . **The coefficients a_{ij} in the primal are transpose of those in the dual. That is, the coefficients in the primal become column coefficients in the dual, and vice-versa.**

The observations can be summarized in the form of a table below:

	Maximisation Problem		Minimisation Problem
1	No. of constraint	\leftrightarrow	No. of variables
2	(\leq) Constraints	\leftrightarrow	Non-negative variable
3	(\geq) Constraints	\leftrightarrow	Non-positive variable
4	$(=)$ Constraints	\leftrightarrow	Unrestricted variables
5	Number of variables	\leftrightarrow	Number of constraint
6	Non-negative variable	\leftrightarrow	(\leq) Constraints
7	Non-positive variable	\leftrightarrow	(\geq) Constraints
8	Unrestricted variables	\leftrightarrow	$(=)$ Constraints
9	Objective function coefficient for j^{th} variable	\leftrightarrow	Right-hand-side constant for j^{th} constraint
10	Right-hand-side constant for i^{th} constraint	\leftrightarrow	Objective function coefficient for i^{th} variable
11	Coefficient in constraint i for variable j	\leftrightarrow	Coefficient in constraint j for variable i

The following figure shows this relationship between primal and dual.

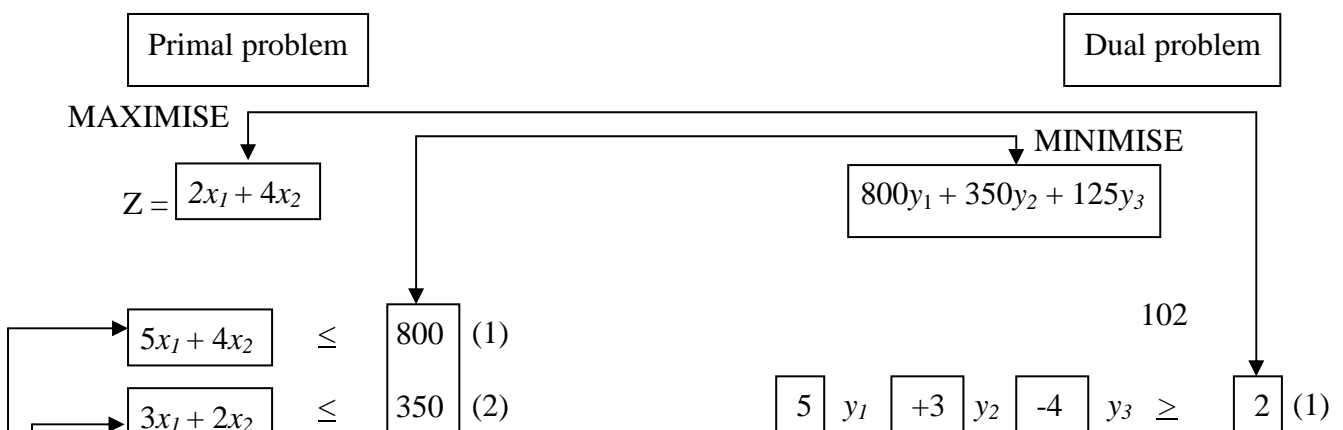

$$Z =$$

Subject to

Subject to

Example 1 The following is a primal problem

Minimise $Z = 10x_1 + 20x_2 + 15x_3 + 12x_4$

Subject to $x_1 + x_2 + x_3 + x_4 \geq 100$

$$2x_1 - x_3 + 3x_4 \leq 140$$

$$x_1 + 4x_2 - 2x_4 = 50$$

$$x_1, x_3, x_4 \geq 0, x_2 \text{ unrestricted}$$

Formulate its corresponding dual.

Solution.

Primal problem

Dual problem

MINIMISE

$$Z = 10x_1 + 20x_2 + 15x_3 + 12x_4$$

MAXIMISE $Z = 100y_1 + 140y_2 + 50y_3$

$$x_1 + x_2 + x_3 + x_4 \geq 100$$

$$2x_1 - x_3 + 3x_4 \leq 140$$

y_1	y_2	y_3
1	2	1
1	-1	4
1		2

$$103 \leq 10$$

Subject to

Dual is

$$\begin{aligned} \text{Max } Z &= 100y_1 + 140y_2 + 50y_3 \\ \text{Subject to } & y_1 + 2y_2 + y_3 \leq 10 \\ & y_1 + 4y_3 = 20 \\ & y_1 - y_2 \leq 15 \\ & y_1 + 3y_2 - 2y_3 \leq 12 \\ & y_1 \geq 0, y_2 \leq 0, y_3 \text{ unrestricted} \end{aligned}$$

It has been seen earlier in the table comparing the primal and the dual that an equality constraint in one problem corresponds to an unrestricted variable in the other problem. An unrestricted variable can assume a value which is positive, negative or 0. Similarly, a problem may have non-positive variable. ($x_1 \leq 0$)

Example 2. The following primal is given

$$\begin{aligned} \text{Maximise } Z &= 5x_1 + 6x_2 \\ \text{Subject to } & 5x_1 + 2x_2 \leq 120 \\ & 4x_1 + 6x_2 \leq 260, \quad x_1, x_2 \geq 0 \end{aligned}$$

Find the corresponding dual of the primal

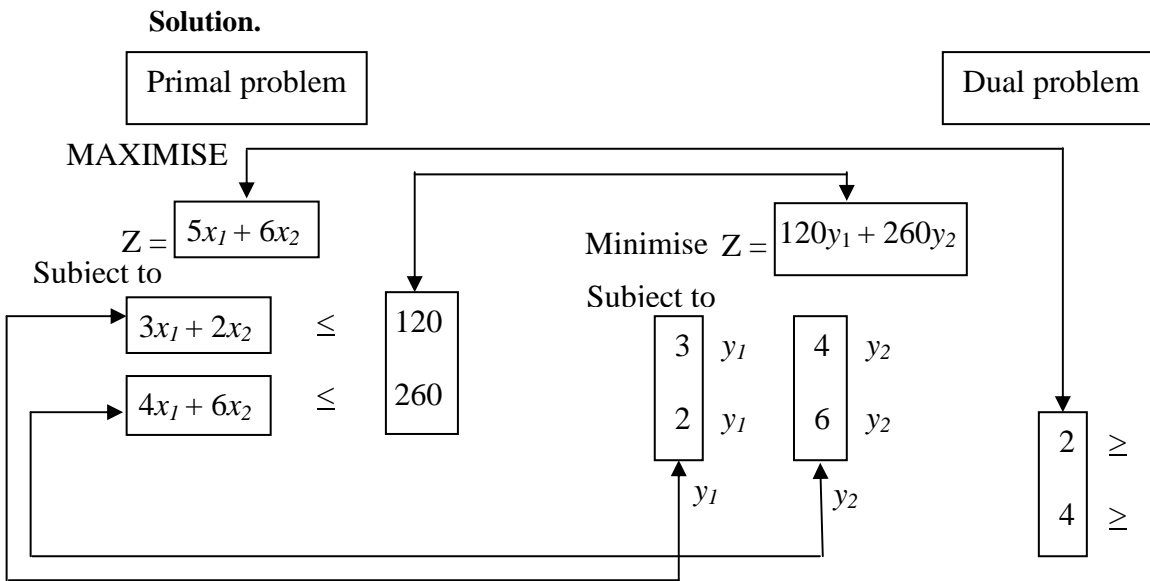

Hence the dual is

$$\begin{aligned}
 Z &= 120y_1 + 260y_2 \\
 3y_1 + 4y_2 &\leq 5 \\
 2y_1 + 6y_2 &\leq 6 \\
 y_1 - y_2 &\geq 0
 \end{aligned}$$

3.3. INTERPRETING PRIMAL – DUAL OPTIMAL SOLUTIONS

As has been said earlier, the solution values of the primal can be read directly from the optimal solution table of the dual. The reverse of this also is true. The following two properties of primal-dual should be understood.

Primal – Dual Property 1

If feasible solution exists for both primal and dual problems, then both problems have an optimal solution for which the objective function values are equal. A peripheral relationship is that, if one problem has an unbounded solution, its dual has no feasible solution.

Primal – Dual Property 2.

The optimal values for decision variables in one problem are read from row (0) of the optimal table for the other problem. The following steps are involved in reading the solution values for the primal from the optimal solution table of the dual:-

- Step I.** The slack-surplus variables in the dual problem are associated with the basic variables of the primal in the optimal solution. Hence, these slack-surplus variables have to be identified in the dual problem.
- Step II.** Optimal value of basic primal variables can be directly read from the element in the index row corresponding to the columns of the slack –surplus variables with changed signs.
- Step III.** Values of the slack variables of the primal can be read from the index row under the non-basic variables of the dual solution with changed signs.
- Step IV.** Value of the objective function is same for primal and dual problems

Example 3. Solve the following LPP using its dual.

$$\begin{aligned} \text{Maximise } & Z = 5x_1 - 2x_2 + 3x_3 \\ \text{Subject to } & 2x_1 + 2x_2 - x_3 \geq 2 \\ & 3x_1 - 4x_2 \leq 3 \\ & x_2 + 3x_3 \leq 5 \\ & x_1, x_2, x_3 \geq 0 \end{aligned}$$

Solution.

The problem can be rewritten as

$$\begin{aligned} \text{Maximise } & Z = 5x_1 - 2x_2 + 3x_3 \\ \text{Subject to } & -2x_1 - 2x_2 + x_3 \leq -2 \\ & 3x_1 - 4x_2 \leq 3 \\ & x_2 + 3x_3 \leq 5 \\ & x_1, x_2, x_3 \geq 0 \end{aligned}$$

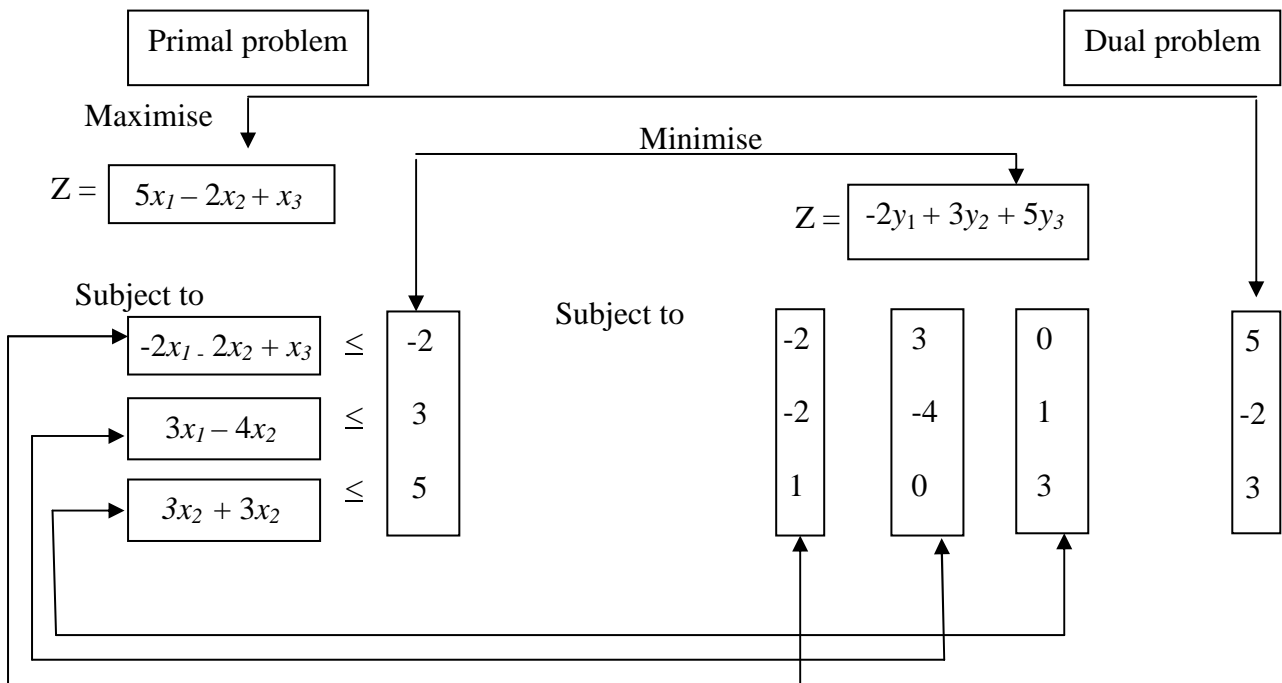

The dual is Minimise $Z = -2y_1 + 3y_2 + 5y_3$
 Subject to the constraint $-2y_1 + 3y_2 \geq 5$

$$\begin{aligned}
-2y_1 - 4y_2 + y_3 &\geq -2 \\
y_1 + 3y_3 &\geq 3 \\
y_1, y_2, y_3 &\geq 0
\end{aligned}$$

Step I. Convert the minimization into maximization problem

Maximize $Z^* = 2y_1 - 3y_2 + 5y_3$

Step II. Make RHS of constraints positive.

$$\begin{aligned}
-2y_1 - 4y_2 + y_3 &\geq -2 \text{ is rewriting as} \\
2y_1 + 4y_2 - y_3 &\geq 2
\end{aligned}$$

Step III. Make the problem as N + S coordinates problem

Maximize $Z^* = 2y_1 - 3y_2 + 5y_3 + 0S_1 + 0S_2 + 0S_3 - MA_1 - MA_3$

Subject to $-2y_1 + 3y_2 - S_1 + A_1 = 5$

$2y_1 + 4y_2 - y_3 + S_2 = 2$

$y_1 + 3y_3 - S_3 - A_3 = 3$

$y_1, y_2, y_3, S_1, S_2, S_3, A_1, A_3 \geq 0$

Step IV. Make N coordinates assume 0 values

Putting $y_1 = y_2 = y_3 = S_1 = S_3 = 0$

We get $A_1 = 5, S_2 = 2, A_3 = 3$ is the basic feasible solution. This can be represented in the table as follows.

Initial Solution

C_j			2	-3	-5	0	0	0	-M	-M	Min ratio
C_B	Basic variable	Solution variables	y_1	y_2	y_3	S_1	S_2	S_3	A_1	A_3	
-M	A_1	5	-2	3	0	-1	0	0	1	0	$\frac{5}{3}$
0	S_2	2	2	4	-1	0	1	0	0	0	$\frac{1}{2} \rightarrow$
M	A_3	3	1	0	3	0	0	-1	0	1	∞
Z_j			M	-3M	-3M	M	0	M	-M	-M	
$(C_j - Z_j)$			2-M	-3+M	-5+3M	-M	0	-M	0	0	

Step V. $C_j - Z_j$ is + ve under some column, it is not the optimal solution. Perform the optimality test.

Step VI. We second, third or fourth Simplex table unless you come to the optimal solution. This has been provided in the table below.

Optimal Solution

C_j			2	-3	-5	0	0	0	-M	-M
C_B	Basic variable	Solution variables	y_1	y_2	Y_3	S_1	S_2	S_3	A_1	A_3
0	S_3	11	-15	0	0	-4	-3	1	4	-1
-3	y_3	$\frac{5}{3}$	$\frac{2}{3}$	1	0	$-\frac{1}{3}$	0	0	$\frac{1}{3}$	0
-5	y_3	$\frac{14}{3}$	$-\frac{14}{3}$	0	1	$-\frac{4}{3}$	-1	0	$\frac{4}{3}$	0
Z_j			$\frac{76}{3}$	-3	-5	$\frac{23}{3}$	5	0	$-\frac{23}{3}$	0
$(C_j - Z_j)$			$-\frac{70}{3}$	0	0	$-\frac{23}{3}$	-5	0	$-\frac{23}{3} - M$	-M

Since all the values in $(C_j - Z_j)$ are – ve, this is the optimal solution.

4.0. CONCLUSION

The conclusion is as in the summary.

5.0. SUMMARY

In summary, the Dual problems when primal is in the standard form have been extensively discussed, the Dual of the primal problem formulated and several examples were solved in this unit.

6.0. TUTOR MARKED ASSIGNMENT

Write the dual of the following LPP and hence solve.

$$\text{Minimize } Z = 3x_1 - 6x_2 + 4x_3$$

Subject to the constraints

$$4x_1 + 3x_2 + 6x_3 \geq 9$$

$$x_1 + 2x_2 + 3x_3 \geq 6$$

$$6x_1 - 2x_2 - 2x_3 \leq 10$$

$$x_1 - 2x_2 + 6x_3 \geq 4$$

7.0. REFERENCES/FURTHER READINGS

1. Operations Research. By Prem Kumar Gupta and D.S. Hira
2. Operations Research. (Problem Solvers) By Research and Education Association.
11. Statistics and Operations Research. By Debashis Dutta
12. Operations Research By). O.T. Arowolo and G.O. Lawal

MODULE 2

UNIT 1 CONCEPT OF INTEGER PROGRAMMING

15.0. Introduction

16.0. Objective

17.0. Main Content

3.1. LIMITATIONS OF INTEGER PROGRAMMING

3.2. METHODS OF INTEGER PROGRAMMING

3.3. INTEGER PROGRAMMING FORMULATION

3.4. BRANCH AND BOUND METHOD

18.0. Conclusion

19.0. Summary

20.0. Tutor Marked Assignment

21.0. Reference/ Further Readings

7.0 INTRODUCTION

In mathematical programming problems, sometimes the values of the result come out to be negative and fraction, in such cases the solution is not optimal. In Linear Programming it is assumed that the decision variables can take continuous values i.e. these could be fractions or in integer. Integer Programming deals with solutions in which some or all the variables can assume integers non-negative values only. In LPP, the result may recommend the use of 4.5 machines or employing 6.5 men, which has no meaning as fractional machines and men cannot be used. Hence,, there is a need to have a programming system where the results are always only integers and not fractions. This need is met by the Integer Programming techniques. We could have.

- (a) Pure Integer Linear Programming. If all the variables take only integer values.
- (b) Mixed Integer Linear Programming – if some of the variables are restricted to have only integer values while others could have fractional values as the case may be in real life applications of the problem.

8.0 OBJECTIVE

- * Understand limitations of integer programming
- * Identify the methods of integer programming
- * Formulate integer programming model

* Solve IP problems using branch and bond method

9.0 MAIN TEXT

3.1 LIMITATIONS OF INTEGER PROGRAMMING

We have seen that in LP problems with large and complex data can be solved in a reasonable time, however the performance of integers algorithms has not been found to be uniformly efficient and useful. In integer programming rounding off is used to a value approximately true or correct. Rounding off is done in such a manner that the closet possible or nearest number is taken. If the result is 22.3 men, obviously the approximation is 22 men and not 23 men. This intersects rounding off error. This type of error or approximation may be acceptable when we talk of discrete number of variables like men, machines etc, however when we are using this algorithm for solution of financial investments, it is not rational or logical to make use of integers only. Here, in fact, it is required that exact values of money are worked out for the best possible results.

3.2 METHODS OF INTEGER PROGRAMMING

The following two integer programming methods are available.

Cutting Plane Method. In this method of Integer Linear Programming certain 'secondary' conditions are added in such a manner that the ultimate result satisfies the conditions of only integer solutions. These 'secondary' conditions 'cut' or eliminate certain aspects of the solution which are not feasible integers. Thus the name 'cutting methods'.

Search Methods. Here all the possible feasible integers only are considered as the solution. The best known search method is called the branch-and-Bound techniques. A special case of each methods is when all the integer variables are binary in nature.

Cutting-Plane Algorithm

This method was developed by RE Gomory for pure-integer problems as also for mixed integer problems. Fractional algorithm and mixed algorithm are applied to the two problems respectively. The following steps are involved in finding the solutions.

Step I. Minimization problem is converted into maximization problem.

Step II. Solve this maximization problem without considering the condition of integer values

Step III. If the optimal solution found in step II for the variables, does not have integer values, then moves to step IV as given below.

Step IV. Carry out the test of integrality of the solution.

Determine the highest fraction value in solution value column of the solution. Select the row with the largest value. If there is a negative fraction, convert this into the sum of negative and a non-negative fraction. Than the row which contained the largest fraction is written in the form of an equation. Now we obtained equations with fractional parts of all coefficients by ignoring integral parts and replacing the whole number by zeros.

Step V. Here the technical coefficient = fractional part of a resource availability + some integer. Hence it is equal to or greater than the fractional part of resource availability. So, fractional part is taken to the R.H.S. and the inequation is formed as greater than or equal to (\geq) type. If this is to be converted into \leq type, it is multiplied with -1 and to make it as an inequality a slack is introduced.

Step VI. The constraint is added to the optimum simplex table of the solution found in step II. Now solve the problem by Dual simplex Method.

Step VII. If the solution has all integer values, then this is the optimal solution. However, if there are some fractional values, go back to step III. The procedure is repeated till an optimum solution with all the integer values is obtained. The above method will be explained with the help of examples.

3.3 INTEGER PROGRAMMING FORMULATION

Use the same mathematical notations as were used in the formulation of LPP, the integer programming can be mathematically written as

$$\text{Maximise or optimize } Z = \sum_{j=1}^n C_j X_j$$

Subject to the constraints

$$\sum_{j=1}^n a_{ij} x_j \leq b_i, i = 1, 2, 3, \dots, m$$

$$x_j \geq 0, j = 1, 2, 3, \dots, n$$

and x_j integer value $j = 1, 2, \dots, n$

The most common use of integer programming is found in the real world problems related to investment decisions, budgeting, Production Planning and Control (PPC) in manufacturing industry, traveling salesmen etc. Some of these cases are discussed in succeeding examples.

Example 19.6

An investment consultant has four projects with different investments and present value of expected returns. Funds available for investment during the three proposals are also available. The detailed information regarding the project is as follows.

Project	Investment during year			PV of expected return
	1	2	3	
P – 1	1000,000	600,00	500,00	800,00
P – 2	500,000	200,00	400,00	700,00
P – 3	300,000	250,00	350,00	400,00
P – 4	400,000	300,00	260,00	300,00
Funds for investment	18,00,000	10,00,000	800,000	

Formulate an integer programming model for the consultant to make a decision as to which project should be accepted in order to maximize present value of expected return.

Solution.

Let X_1 , X_2 , X_3 and X_4 be the investment on projects P – 1, P – 2, P – 3 and P – 4 respectively.

$$\text{Maximize } Z = 8,00,000 + 7,00,00,000 \times 2 + 4,00,000 \times 3 + 3,00,000 \times 4$$

Subject to the constraints

$$10,00,000 \times 1 + 5,00,00,000 \times 2 + 3,00,000 \times 3 + 4,00,000 \times 4 \leq 18,00,000$$

$$6,00,000 \times 1 + 2,00,00,000 \times 2 + 2,50,000 \times 3 + 3,00,000 \times 4 \leq 10,00,000$$

$$5,00,000 \times 1 + 4,00,00,000 \times 2 + 3,50,000 \times 3 + 2,60,000 \times 4 \leq 8,00,000$$

Where $X_1, X_2, X_3, X_4 \geq 0$ and are integers.

Example 19.7.

A multinational Company (MNC) is planning to invest in four different projects in Business Process Outsourcing (BPO) industry in an important town of North. The details of the investment of MNC (in thousands of naira) are provided below:

Project	Present value of expected returns	Capital requirement for three years		
		1	2	3
A	800	600	500	550
B	550	900	400	-
C	400	300	200	400
D	250	400	150	100
Funds available for investment	1500	1200	700	500

It is also know that projects A and B are mutually exclusive. However, Project D can only be accepted if project C is acceptable due to technology constraints. Which project should the MNC accept to maximize their present value of expected returns?

Solution.

Let $X_1, X_2, X_3,$ and X_4 be the investment in projects A, B C and D respectively. Also, let $X_i = 1$ (if project j is accepted) and $X_j = 0$ (if project j is rejected)

Maximise (PV of returns) $Z = 800 x 1 + 500 x 2 + 400 x 3 + 250 x 4 \leq 1500$

Subjective to the constraints.

$$600 x 1 + 900 x 2 + 300 x 3 + 400 x 4 \leq 1200$$

$$500 x 1 + 400 x 2 + 200 x 3 + 150 x 4 \leq 700$$

$$550 x 1 + 400 x 3 + 100 x 4 \leq 500$$

$$X_1 + X_2 \geq 1$$

$$- X_3 + X_4 \leq 1$$

$$X_j = 0 \text{ or } 1$$

3.4 BRANCH AND BOUND METHOD

In certain type of problems of the variables of an Integer Programming Problem (PP) have the constraint of a upper limit or a lower limit or both upper and lower bounds. The method used to solve such problem is called Branch & Bound Method and is applicable to pure as well mixed IPP.

The basic method involves dividing the feasible region into smaller sub-sets, each sub-set is considered sequentially until a feasible solution giving he optimal value of objective function is arrived at. The procedure is as given un the following steps.

Step I. Optimal solution of the Linear Programming problem is obtained without considering the restrictions of integer

Step II. Test the integrality of the optimal solution obtained above

(b) If the solution turns out to be in integers, then this is the optimum solution of the given IPP

(c) If the solution is not in integers, then proceed to step II

Step III. Consider the upper bound values of the objective function, determine the lower bound values by rounding of to the integer values of the decision variables.

Sub-Problem I – Given LPP with an additional constraint $x_j < [x_j^*]$

Sub-Problem II – Given LPP with an additional constraint $x_j < [x_j^*] + 1$

Where x_j^* is the optimum value of x_j (not an integer) and $[x_j^*]$ is the largest integer contained in x_j^* .

Step V. Solve the above two sub problems. The following cases may arise.

- (b) Optimum solution of the two sub-problem is in integers, then the solution obtained is the optimal solution.
- (c) (b) One-sub problem – Integral
Second – sub problem – No feasible solution

In this case, the optimum solution is that of the integral solution of sub-problem one. Second sub-problem solution is ignored.

- (d) One sub-problem – integral
Second sub – problem – Non – integral

In this case, repeat the steps III and IV for the second sub problem

Step VI. Repeat steps III to V until we get all solutions with integral values.

Step VII. Out of the integral value solution achieved, select the one which gives the optimum value of Z.

Example 2

$$\text{Min } Z = -4x_1 + x_2 + 2x_3$$

Subject to

$$2x_1 - 3x_2 + 2x_3 \leq 12$$

$$-5x_1 + 2x_2 + 3x_3 \geq 4$$

$$3x_1 - 2x_3 = -1$$

$$x_1, x_2, x_3 \geq 0$$

Solution.

In simple form, the problem reduces to

$$\text{Min } Z = -4x_1 + x_2 + 2x_3$$

$$\text{Subject to } 2x_1 - 3x_2 + 2x_3 + x_4 = 12$$

$$-5x_1 + 2x_2 + 3x_3 - x_5 = 4$$

$$-3x_1 + 2x_3 = -1$$

$$x_1, x_2, x_3, x_4, x_5 \geq 0$$

Since the above equations do not contain basic variables, artificial variables x_6 and x_7 are added to the problem. Then the problem is

$$\text{Min } z = -4x_1 + x_2 + 2x_3 + 0x_4 + Mx_6 + Mx_7$$

Subject to

$$2x_1 - 3x_2 + 2x_3 + x_4 = 12$$

$$-5x_1 + 2x_2 + 3x_3 - x_5 = 4$$

$$-3x_1 + 2x_3 + x_7 = 1$$

Let S_1 to S_7 denote the column vectors corresponding to x_1 to x_7 .

$$P_1 = \begin{bmatrix} 2 \\ -5 \\ -3 \end{bmatrix} \quad P_2 = \begin{bmatrix} -2 \\ 2 \\ 0 \end{bmatrix} \quad P_3 = \begin{bmatrix} 2 \\ 3 \\ 2 \end{bmatrix}$$

$$P_4 = \begin{bmatrix} 1 \\ 0 \\ 0 \end{bmatrix} \quad P_5 = \begin{bmatrix} 0 \\ -1 \\ 0 \end{bmatrix} \quad P_6 = \begin{bmatrix} 0 \\ 1 \\ 0 \end{bmatrix}$$

$$P_7 = \begin{bmatrix} 0 \\ 0 \\ 1 \end{bmatrix} \quad b = \begin{bmatrix} 12 \\ 4 \\ 1 \end{bmatrix}$$

As x_4 , x_6 and x_7 from the initial basis, we have

$$B = [P_4 \ P_6 \ P_7] = \begin{bmatrix} 1 & 0 & 0 \\ 0 & 1 & 0 \\ 0 & 0 & 1 \end{bmatrix} = I$$

$$B^{-1} I = b^{-1} = B^{-1} b = b$$

The initial table of the revised simplex is given below.

Basic variables	B^{-1}	Solution values	Entering Variable	Pivot Column
x_4	$\begin{bmatrix} 1 & 0 & 0 \\ 0 & 1 & 0 \\ 0 & 0 & 1 \end{bmatrix}$	12	x_3	2
x_6		4		3
x_7		1		2

The Simplex multipliers are

$$= (0 \quad M \quad M) \begin{bmatrix} 1 & 0 & 0 \\ 0 & 1 & 0 \\ 0 & 0 & 1 \end{bmatrix} = (0, M, M)$$

$$\therefore C_1 - XP_1 = -4 - (0, \quad M, \quad M) \begin{bmatrix} 2 \\ -5 \\ 3 \end{bmatrix} = 8M - 4$$

$$C_2 - XP_2 = 1 - (0, \quad M, \quad M) \begin{bmatrix} -3 \\ 2 \\ 0 \end{bmatrix} = 1 - 2M$$

$$C_3 - XP_3 = 2 - (0, \quad M, \quad M) \begin{bmatrix} 2 \\ 3 \\ 2 \end{bmatrix} = 2 - 5M$$

$$C_5 - XP_5 = 01 - (0, \quad M, \quad M) \begin{bmatrix} 0 \\ -1 \\ 0 \end{bmatrix} = M$$

As $C_3 - XP_3$ is the most negative values X_3 will be the entering variable.

The first solution is

$$P_3 = B^{-1} P_3 = \begin{bmatrix} 1 & 0 & 0 \\ 0 & 1 & 0 \\ 0 & 0 & 1 \end{bmatrix} \begin{bmatrix} 2 \\ 3 \\ 2 \end{bmatrix} = \begin{bmatrix} 2 \\ 3 \\ 2 \end{bmatrix}$$

2 is the first or key element.

Applying the minimum ratio rule $\frac{12}{2} = 6, \quad \frac{4}{3} = 12, \quad \frac{1}{2} = 5$

Minimum ratio is of X_7 so it will be the outgoing variable.

4.0. CONCLUSION

In conclusion, integral programming has limitation and this leads to integral programming Rounding off.

5.0. SUMMARY

The limitation of integral programming was introduced. Two methods of integral programming were discussed, questions on integral programming were formulated and solved in order to drive home what has been taught in this unit.

6.0. TUTOR MARKED ASSIGNMENT

1. $Min \quad Z = -4x_1 + x_2 + 2x_3$

Subject to

$$2x_1 - 6x_2 + 2x_3 \leq 10$$

$$\begin{aligned} -4x_1 + 2x_2 + 3x_3 &\geq 6 \\ 3x_1 - 2x_3 &= -2 \\ x_1, x_2, x_3 &\geq 0 \end{aligned}$$

7.0. REFERENCES/FURTHER READINGS

1. Operations Research. By Prem Kumar Gupta and D.S. Hira
2. Operations Research. (Problem Solvers) By Research and Education Association.
13. Statistics and Operations Research. By Debashis Dutta
14. Operations Research By). O.T. Arowolo and G.O. Lawal

UNIT 2 CONCEPT OF DYNAMIC PROGRAMMING

22.0. Introduction

23.0. Objective

24.0. Main Content

3.1. IMPORTANT TERMS USED IN DYNAMIC PROGRAMMING

3.2. DYNAMIC PROGRAMMING APPROACH

3.3. FORMULATION AND SOLUTION OF DYNAMIC PROGRAMMING PROBLEMS

25.0. Conclusion

26.0. Summary

27.0. Tutor Marked Assignment

28.0. Reference/ Further Readings

10.0 INTRODUCTION

While discussing problem and solution there of in previous chapters we assumed that values of decision variable, remain constants over the planning period. These problems could be con as static and solution were capable only for specific situation and for a particular period of time. But, as we know, there could be many situation in which decisions variables will change with time, such situations are considered dynamic in nature. Dynamic programming techniques help in finding dynamic solution for such problems.

Dynamic programming was originated by Richard E Bellman and GB Dantzing in early 1950's. It is a quantitative technique which convert one big/large problem having many decision variables into a sequence of problem each with small number of decisions variables. Thus, a big problem which is difficult to solve can be converted into a series of small problems, which can be easily solved it attempts to optimize multi-stage decision variables and uses the word 'programming' in the mathematical sense of selection of optimal allocation of resources. Also, the word 'dynamic' is used to indicate that the decisions are taken at a number of stages like

daily, weekly etc. dynamic programming is different from linear programming in the following ways:

- (a) It does not involve any mathematical computation like of which are done in Simplex method. It uses a multistage approach by dividing the problem in number of sequential stages.
- (b) LP gives a single stage solution. However, dynamic programming helps in finding optimal solution over a period of time, say over a period of six months or one year, by breaking the problem into six or twelve one month time problems and solving each of these.

11.0 OBJECTIVES

- * Understand the terminologies used in dynamic programming
- * Identify the methods of dynamic programming
- * Formulate dynamic programming model
- * Solve dynamic programming problems using branch and bond method

12.0 MAIN CONTENT

12.1 IMPORTANT TERMS USED IN DYNAMIC PROGRAMMING

1. Stage – When a large problem is developed into various sub-problems in a sequence, these are the stages of the original problem. It is in fact, each point where the decision must be made, for example, in salesman allocation, a stage may represent a group of cities, in the case of replacement problem, each year may represent a stage.
2. State – Specific information describing the problem at different stages with the help of variables. The variables linking two stages are called the state variables. In the salesman allocation problem replacement problem the state is the of beginning with a new machine.
3. Principle of Optimality - Bellman’s principle of optimally sates “An optimal policy (a sequence of decision) has the property that whatever he initial state and decisions are, the remaining decisions must constitute an optimal policy with regard to the state resulting from the first decision”. According to this principle, a wrong decision (non-optimal) taken at one stage does not mean that optimum decisions for the remaining stages cannot be taken. This can be shown diagrammatically as follows.

Stage Decision

Stage Decision

Stage Decision

where $n =$ stage number
 $S_n =$ Input to stage n from stage $n + 1$
 $D_n =$ Decision variable at stage n .

4. Forward and Backward Recursive approach – It is the type of computation Forward or Backward depending upon whether we proceed from stage 1 to n i.e. $S_1 \rightarrow S_2 \rightarrow S_3 \rightarrow \dots \rightarrow S_n$ or from stage S_n to S_1 i.e. $S_n \rightarrow S_{n-1} \rightarrow S_{n-2} \rightarrow \dots \rightarrow S_1$.

3.2 DYNAMIC PROGRAMMING APPROACH

Numerical problems and examples can only be discussed after a student has clear understanding of the fundamental concepts of Dynamic Programming. The two most important concepts are the concept of stage. As already brought out above a large problem is broken down into a number of smaller or sub problems and each sub-problem is referred to as a stage. Every stage is a part of the decision problem and a separate decision can be taken for each stage. Stage decision is the selection of one feasible solution out of a large number of alternatives available at every stage of the problem. The stage for decision will contribute to the overall decision of the entire problem. The second very important concept is that of the ‘state’ which provides the specific ‘current status’ conditions or parameters which may be referred to as ‘state variables’.

In the overall decision-making process for the entire problem, a decision made changes the ‘state of the problem’ with the aim of maximizing the returns. The next stage of the problem-solving process uses the values of the state variables which are the outcome of the decision of the previous stage.

3.3 FORMULATIONS AND SOLUTION OF DYNAMIC PROGRAMMING PROBLEMS

The following steps are involved in this:-

Step I. Definition of problem variables, formulation of objectives function in terms of maximization or minimization of an objective and list the problem constraints.

Step II. Specific definition of stages of a multi stage decision problem. This amounts to finding out different variables and their values for each state and specifying the relationship by which the state is determined at one stage with the state and decisions at the next stage.

Step III. Developing optimal return function through recursion relationship. Optimal return function at stage 1 is determined as this is slightly different from the general optimal return function for other stages.

Step IV. Constructing tabular representation clearly showing the values and computations at each stage of the solution. The solution may be developed manually or with the help of a suitable computer software depending upon the complexity of the problem.

Step V. Determining optimal solution. This is done when all stages of the problem have been sequentially solve.

Example 1

(Salesman Employment Smoothing Problem)

A manufacturing company has divided its total target market into three zones. The Company's marketing department has been collecting data regarding the deployment of salesmen and the sales made in each zones. They have realized that the sales are directly dependent upon the number of salesmen in each zone. The data collected by the company is given in the table below. For various reasons, the company has decided to retain only 9 salesmen during the next year. The problem is to determine allocation of these salesmen to three different zones so that the totals sales cab neb maximized.

No of Salesmen	Profits in thousands of Naira		
	Zone 1	Zone 2	Zone 3
0	35	40	45
1	40	50	50
2	45	65	60
3	60	75	70
4	70	85	80
5	80	95	90
6	90	100	100
7	105	105	110
8	100	100	120
9	90	105	100

Solution.

In this problem, the solution can be obtained by step process. The problem is to allocate 9 salesmen into three marketing zones to maximize total sales and hence profits. In this problem.

Three stages are the three zones and state variables are the number of salesmen varying from 0 to 9. For zone 1, the return corresponding to deployment of different number of salesmen are as follow:

		Zone 1								
No of salesmen		0	1	2	3	4	5	6	7	8
9										
Sales (in thousands of Rupees)	35	40	45	60	70	80	90	90	105	100
90										

Let us consider zone 1 and zone 2 together Nine salesmen can be divided into two zone 1 and 2 in 10 different ways. This is shown below:

No of salesmen	Zone I	x_1	9	8	7	6	5	4	3	2	1	0
	Zone II	x_1	0	1	2	3	4	5	6	7	8	9
Sales (in thousands of rupees)	Zone I	$f_1(x_1)$	90	100	105	90	80	70	60	45	40	35
	Zone II	$f_2(x_2)$	40	50	65	75	85	95	100	10	100	105
	Total		130	150	170	165	165	165	160	150	140	140

Where x_1, x_2 are the salesmen in zone 1 and Zone 2 respectively

and $f_1(x_1)$ = sales from zone I

$f_2(x_2)$ = sales from zone II

Let S = Total sales from each combination

$$\begin{aligned}
 \text{Then } S &= f_1(9) + f_2(0) \\
 &= f_1(8) + f_2(1) \\
 &= f_1(7) + f_2(2) \\
 &: \\
 &: \\
 &= f_1(0) + f_2(9)
 \end{aligned}$$

In general $S = f_1(x) + f_2(9-x)$

Or $S = f_1(x) + f_2(A - x)$

Where A is the number of salesmen to be allocated to Zone 1 and Zone 2

Maximise $S = F(A) [f_1(x) + f_2(A - x)]$

F(A) is the maximum sales

This equation can be used to determine the optimum distribution of any number of salesmen. In the present case of 9 salesmen, the distribution in zone 1 and zone 2 is shown below.

Fig 1

Expected sales for all combination are provided in the table. For a particular number of allocation of salesmen, the sales can be read along the diagonal. For example if 3 salesmen are to be distributed in the two zones the sales in combination possible are 3+0, 2+1, 1+2, 0+3 and can be read along diagonal 3 – 3. Maximum profit of # 1, 10,000 results from combination of 0 salesmen for zone 1 and 3 for zone 2. The optimum results for all combinations can be tabulated as follows.

	Maximum Sales from Optimum allocation of Salesmen in Zone 1 and Zone 2									
No of Salesmen A	0	1	2	3	4	5	6	7	8	9
Total sales $f_1(x_1) + f_2(x_2)$	75	85	140	110	120	130	135	145	155	170
$(x_1 + x_2)$	0 + 0	0 + 1	0 + 2	0 + 3	0 + 3	0 + 5	1 + 5	3 + 4		

Now, we can move to the next stage and 9 -salesmen can be allotted to three zones Zone 1, Zone 2 and Zone 3. It means allotting certain salesmen to zone 3 and the balance would be allotted to Zone 1 and Zone 2 put together and then further they will be distributed between Zone 1 and Zone 2. For example, we allot 4 salesmen to Zone 1 and 2 and between 5 to Zone 3, then the best sales would be

$$S = F(4) + f_3(5)$$

where $F(4)$ – Maximum sales by Zone 1 and Zone 2

$F(5)$ – Maximum sales in Zone 3 if salesmen are allotted in general, it can be written as

$$S = F(x) + f_3(A - x)$$

where x = Salesmen allotted to one 1 and Zone 2 combined

$(A - x)$ = Salesmen allotted to Zone 3.

i.e. Maximise $S = F(A) = F(x) + f_3(A - x)$, $0 \leq x \leq A$

Let us use the subscript II for the first two zones *i.e.* Z_1 and Z_2

then $F_3(A_3) = \text{Maximum } [F_{II}(A_{II}) + f_3(A_3 - A_{II})]$, $0 \leq x \leq A_3$

The calculations for selecting the optimum combination of A_{II} and $(A_3 - A_{II})$ with $A_3 = 9$ can be carried out the same way as done earlier. It is represented in the following table

No of Salesmen in Zone 1 + Zone 2

Fig 2

It can be seen optimum combination is along diagonal 9 – 9 i.e. 7 salesmen in Zone 3 and 2 combined in Zone 1 and Zone 2. This gives maximum sales of # 250,000. Further distribution of 2 salesmen in Zone 1 and Zone 2 can be seen from our earlier table *i.e.* maximum sale of 140,000 for 2 salesmen i--Zone 2 and 0 in Zone 1.

4.0. CONCLUSION

As in the summary

5.0. SUMMARY

This unit focuses on stage, state and principle of optimality (forward and backward recursive approach. The Dynamic programming approach, formulation and solution of Dynamic programming problems.

6.0. TUTOR MARKED ASSIGNMENT

1. Explain the important terms in Dynamic programming that you have learnt.
2. State and explain the steps that are involved in the formulation and solution of Dynamic programming.

7.0. REFERENCES/FURTHER READINGS

1. Operations Research. By Prem Kumar Gupta and D.S. Hira
2. Operations Research. (Problem Solvers) By Research and Education Association.
15. Statistics and Operations Research. By Debashis Dutta
16. Operations Research By). O.T. Arowolo and G.O. Lawal

UNIT 3 CONCEPT OF GOAL PROGRAMMING

29.0. Introduction

30.0. Objective

31.0. Main Content

3.1. Formulation of Goal Programming mathematical model

3.2. Graphical method of solving Goal Programming problems

4.0. Conclusion

32.0. Summary

33.0. Tutor Marked Assignment

34.0. Reference/ Further Readings

13.0 INTRODUCTION

Goal programming is relatively a new concept, the work on which began only in early sixties and has been developed during the seventies by Charnes Cooper and Lee. When the multiple goals of an organization are conflicting, goal programming is helpful. It may be defined as :

:Goal Programming is a mathematical problem in which the constraints of linear programming problems are treated as goals in the objective function. Effort is made to come as close as possible to the achievement of the goals in order of priority set by the decision-makers”.

We have seen in the previous chapters, that we have restricted ourselves to the goal of either maximizing profits or minimising costs in the linear programming problems. An organization can have many objectives and that too with conflicting interests. It is not possible to solve such real life problems with the help of mathematical model already developed as these can solve only one objective function. As mentioned earlier any organization can have a number of objectives as a matter of fact, Peter F. Drucker, the management guru of the century has suggested eight objectives for the organizations. Some of them are, increasing market share, maximizing the returns of different types of stake holders, social responsibility and so on. Such objectives are selected by the management based on their philosophy, mission and strategy that they want to follow.

Since the LPP can measure the objective function in one dimension only i.e. it can either maximize profit or minimize profit or minimize costs, a new mathematical techniques has been developed to find solution to problems with multiple, often conflicting objectives. In this technique all goals of the management are considered in the objective function and only business environment constraints are treated as constraints. Also, goal are set to be satisfied to the best fit solution ‘as close as possible’ level and not for optimal or best fit solutions. A set of solution satisfying the business environment conditions/constraints are provided in order of priority and effort is made to minimize the deviation from the set goals. There have been very few

applications for Goal Programming techniques in business and industry. First effort to use this technique was made by Charnews Cooper who used it for advertising planning and also for manpower planning problems. Though Goal Programming has lot of flexibility and can have applications as wide-ranging as that of Linear Programming, yet its potential has not been realized and not much work done in this field. It is useful in the practical problems and it is more realistic in its approach. Some of the area. Where Goal Programming may be used are:-

- b. Marketing Management. Marketing management is a very vast discipline in which the organization could have many objectives and that too conflicting i.e. it is possible to achieve one at the cost of the other. Goals could be
 - (d) Maximising market share
 - (e) Maximising profit margin/item sold
 - (f) Minimise advertising costs
 - (g) Optimise brand image
- c. Production Planning and Control (PPC). There are lot of contradicting requirements in production, like
 - i. Minimise operation time
 - ii. Minimise cost
 - iii. Maximise quality of the product
 - iv. Optimise resource utilization
- d. Inventory Management. Conflicting goals could be
 - i. Minimise stock outs
 - ii. Minimise storage cost
 - iii. Minimise Lead time (Just in Time)

It must be noted that Goal Programming aims at satisfaction of the goals set by the management or decision-makers. Exact achievement of the objectives is not aimed. The technique attempts to do so in order of priority of the objectives, again decided by the management. Often, it is a complex task for decision-maker to decide the priority and accept the solution as satisfactory.

14.0 OBJECTIVE

At the end of this unit you should be able to

- * Understand the concept of goal programming
- * Use multiple goals as goal programming problem
- * Formulate goal programming model
- * Solve goal programming problems graphical

15.0 MAIN CONTENT

3.1 Formulation of Goal Programming Mathematical Model

As seen earlier, the first and the most important step in solution of a problem is the ability of the management to convert the problem into a mathematical model which represents the problem. Here a number of assumptions have to be made perforce as we are trying to convert the real life situation into a scientific model written on piece

of paper, unless the problem is very clearly conceptualized by the experts it will not represent the real world problems and solution will give misleading results. It is a complex process. Finding the solution, using the model is again a very time consuming, complicated and cumbersome process, however the computers and their software can help decision-maker a great deal in this.

Steps involved in formulation of the goal programming model are as follows:-

Step I. Identification of decision-variable and constraints. This is the vital step in finding a solution to the problem. Clear identification of all the decision variables and environment conditions which are the constraints in the equations on the RHS have to be determined. RHS constraints are:-

- (i) Available resources as specified in the problem.
- (ii) Goals specified by the decision-maker

Step II. Formulation of objectives or goals of the problem. As discussed earlier an organization could have more than one objectives. Some of these could be

- (i) Maximise profits.
- (ii) Maximise gain of share-holders.
- (iii) Maximise Machine utilization
- (iv) Maximise Manpower utilization
- (v) Maximise Mean Time Between Failures (MTBF) of machines
- (vi) Minimise operation costs
- (vii) Minimise operational time of the machine
- (viii) Minimise overall time of production of the production
- (ix) Optimise use of raw material.
- (x) Satisfy social responsibilities
- (xi) Maximise quality of the product
- (xii) Satisfy many Government rules and other legal requirements.

4. Step III. Formulation of the Constraints.

The constraints of the problem must be formulated. A constraint represents relationship between different variables in a problem. It could be the relationship between the decision-variables and the goals or objectives selected to be satisfied in order of priority.

5. Identify least important and redundant goals.

This is done to remove these from the problem which helps in simplifying the problem to some extent. This is again based on the judgment of the management.

6. Establishing the objective function.

Objective function has to be established based on the goals selected by the decision maker. Priority weightage factors have to be allotted to deviational variables. The goal process models can be mathematically put as

Minimise Objective function $Z = \sum_{i=1}^m W_i (d_i^+ + d_i^-)$

Subject to the constraints

$$\sum_{i=1}^n a_{ij} X_j + d_i^- + d_i^+ = b_i \text{ where } i=1, 2, 3, \dots, n \text{ and } x_j, d_i^-, d_i^+, i, j \geq 0$$

Where j is the decision variable.

W_i = is the weightage of goal i

d_i^- = degree of underachievement of goal i

d_i^+ = degree of overachievement of goal i

As seen earlier, Goal Programming attempts at full or partial achievement of goals in order of priority. Low priority goals are considered only after the high priority goals have been considered. This is very difficult to decide, as contribution of a particular goal to the overall well-being of an organisation is very difficult to determine. The concept of underachievement of goals or overachievement of goals may be understood as the most important. Selected goal continues to remain in the problem unless and until the achievement of a lower priority goal would cause the management to fail to achieve a higher priority goal.

Example 1.

ABC Ltd produces two types of product P-1 and P – 2 using common production facilities which are considered a scarce resource by the company. The scarce production facilities are in the two departments of Machining and Assembling. The company is in a position to sell whatever number it produces as their brand enjoys the market confidence. However, the production capacity is limited because of the availability of the scarce resources.

The company wants to set a goal maximum daily profit, because of its other problems and constraints and would be satisfied with #2000 daily profit.

The details of processing time, capacities of each of the departments and unit profit combinations of products P – 1 and P – 2 are given in the table below:

Type of product	Time to process each product (Hours)		Profit contribution per unit
P – 1	3	1	200
P – 2	2	1	300
Time available (hours) per day	100	50	

The company wishes to know the product mix that would get them the desired profit of

#2000 per day. Formulate the problem as goal programming model.

Solution.

Let X_1 be the number of units of P – 1 to be produced

Let X_2 be the number of units of P –21 to be produced

d_i^- = the amount by which actual profit will fall short of #2000/day

d_i^+ = the amount by which actual profit will exceed the desired profit of # 2000/day

Minimise $Z = d_i^- + d_i^+$

Subject to $3 \times 1 + 2 \times 2 \leq 100$ (Machine hours constraint)

$X_1 + X_2 \leq 50$ (Assembly hours constraint)

and $200 \times 1 + 300 \times 2 + d_i^- + d_i^+ = 2000$. (Desired profit goal constraint)

where $X_1, X_2, d_i^+ + d_i^- \geq 0$

Example 2

The manufacturing plant of an electronic form produces two types of television sets, both colour and black and white, according to the past experience, production of either a colour or a black and white set requires on an average of one hour in the plant. The plant has a normal production capacity of 40 hours a week. The marketing department reports that, because of the limited sales opportunity, the maximum number of colour and black-and-white set that can be sold are 24 and 30 respectively for the week. The gross margin from the sale of a colour set is # 80, where as it is 40 from the black-and-white set.

The chairman of the company has set the following goals arranged in the order of their importance to the organization.

(i) *First he wants to avoid an under-utilization of normal production capacity (on lay offs of production workers).*

(ii) *Second he wants to sell as many television sets as possible. Since the gross margin from the sale of colour television set is twice the amount from a black-and-white, he has twice as much desire to achieve sale for colour sets as for black-and-white sets.*

(iii) *Third the chairman wants to minimize the overtime operation of the plant as much as possible. Formulate this as a goal programming problem and solve it.*

Solution.

Let X_1 and X_2 denotes the number of colour TV sets and number of black-and-white TV sets for production respectively.

(i) The production capacity of both types of TV sets is given by

$$X_1 + X_2 + d_1^- + d_1^+ = 40 \quad d_1^+ \text{ and } d_1^- \text{ are deviational variables.}$$

respectively under utilization and over –utilization (overtime of normal operation of plant respectively

(ii) The sale capacity of two types of TV sets is given by

$$X_1 + d_2^- - d_2^+ = 24$$

$$X_2 + d_3^- - d_3^+ = 30$$

Where $d_2^- - d_2^+$ are the deviational variables representing under achievements of sales towards goals and $d_3^- - d_3^+$ represent deviational variables to represent over achievement of sales goals.

(iii) Let P_1 and P_2 be the priority of the goals, complete mathematical formulation of goal programming is

$$\text{Minimise } Z = p_1 d_1 + 2 p_1 d_2^- + p_2 d_3^- + p_2 d_1^+$$

Subject to the constraints

$$X_1 + X_2 + d_1^- - d_1^+ = 40, X_1 + d_2^- - d_2^+ = 24$$

$$X_3 + d_3^- - d_3^+ = 30 \text{ and } X_1, X_2, d_1^-, d_2^-, d_3^-, d_1^+, d_2^+, d_3^+ \geq 0$$

3.2. Graphical method of solving Goal Programming problems

The graphical method used in Goal Programming is quite similar to the one used in Linear Programming problems. The only difference is that in LPP only one objective function is achieved either maximization or minimization with only one goal. In Goal Programming, there are a number of goals and total deviation from these goals is required to be minimized. The minimization of deviations is done in order of priority. The following procedure is followed:

Step I. Formulation of Linear Goal Programming Mathematical model

Step II. Construction of graph of all goals in relation with the decision variables.

For each goal write an equation with positive and negative deviation variables and set the equation to zero. For all the goal equation two points are selected arbitrarily and joined with straight lines. Positive deviations are indicated with \rightarrow arrow and negative deviation by \leftarrow arrow for each goal.

Step III. Determine the goal line of that goal which has the highest priority. Identify the feasible region (area) with respect to the goal with highest priority.

Step IV. Proceed to the next highest priority and determine the best solutions space with respect to these goals corresponding to this priority.

Step V. Determine the optimal solution

Example 3

A manufacturer produces two types of products A and B. The plant has production capacity of 500 hours a month and production of product A or B or an average requires one hour in the plant. The number of products A and B sold every month and the net profit from the sales of these products are given in the following table.

Type of product	Number sold in a month	Net Profit
A	250	
B	300	

The MD of the company has set the following goals which are arranged in order of priority

P₁ No under utilization of plant production capacity

P₂ Sell maximum possible numbers of products A and B. The MD has twice as much desire to sell product A as for product B, because the net profit from the sale of product A is twice the amount from that of product B.

P₃ Minimise overtime operation of the plant

Formulate the above as a goal programming problem and solve it

Solution.

Let X₁ and X₂ be the number of products of A and B. Since overtime operations are not allowed

Where d_1^- = under utilization of production capacity constraint)

d_1^+ = overtime production operation capacity variable

Since goal is the maximization of sales, hence positive deviation will not appear in constraints related with sales.

$$\text{Then } X_1 + d_2^- = 250$$

$$\text{and } X_2 + d_3^- = 300$$

where d_2^- = under achievement of sales goal for product A

d_3^- = under achievement of sales goal for product B

Now, the goal programming mathematical model can be written as

Minimise $Z = p_1 d_1^- + 2p_2 d_2^- + p_2 d_3^- + p_3 d_1^+$

Subject to the constraints

$$X_1 + X_2 + d_1^- - d_2^- = 500$$

$$X_1 + d_2^- = 250$$

$$X_2 + d_3^- = 300$$

and $X_1, X_2, d_1^-, d_3^-, d_1^+ \geq 0$

All the goal constraints can be plotted on the graph as shown below:

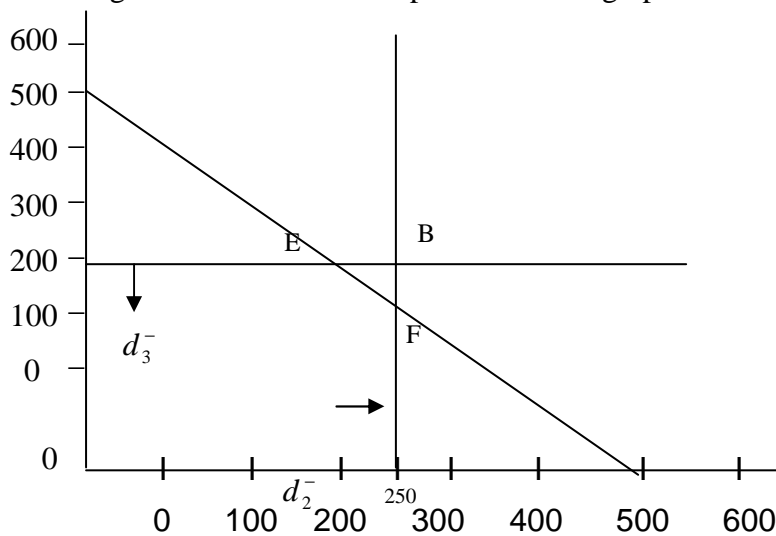

Fig. 1

Example 4

Use Dynamic Programming to show that

$$Z = p_1 \log p_1 + p_2 \log p_2 + \dots + p_n \log p_n$$

subject to the constraints

$$p_1 + p_2 + \dots + p_n = 1 \text{ and } p_j \geq 0 \text{ (} j = 1, 2, \dots, n \text{) is minimum}$$

$$\text{when } p_1 = p_2 = \dots = p_n = \frac{1}{n}$$

Solution.

The constraints $p_1 + p_2 + \dots + p_n = 1$ indicates that the problem is to divide unity into n parts (p_1, p_2, \dots, p_n) so that $\sum_i p_i \log p_i$ ($i = 1, 2, \dots, n$) minimum

Let the minimum sum of $p_i \log p_i = f_n(1)$

Stage 1. For $n = 1$, we have

$f_1(1) = \min (p_1 \log p_1) = 1 \log 1$ $0 < x \leq 1$ as at this stage 1 is divided only into $p_1 = 1$ part

Stage 2. For $n = 2$, 1 is divided into two part p_1 and p_2 in such a manner that $p_1 + p_2 = 1$

If $p_1 = x$ then $p_2 = 1 - x$, Hence

$$\begin{aligned} f_2(1) &= \min_{0 < x \leq 1} \{p_1 \log p_1 + p_2 \log p_2\} \\ &= \min_{0 < x \leq 1} \{x \log x + (1-x) \log (1-x)\} \\ &= \min_{0 < x \leq 1} \{x \log x + f_1(1-x)\} \end{aligned}$$

In general

$$\begin{aligned} f_n(1) &= \min_{0 < x \leq 1} [p_1 \log p_1 + p_2 \log p_2 + \dots + p_n \log p_n] \\ &= \min_{0 < x \leq 1} [\log x + f_{n-1}(1-x)] \end{aligned}$$

For $n = 2$ (stage 2)

The function $x \log x + (1-x) \log (1-x)$ is minimum at $x = \frac{1}{2}$ so as to satisfy $0 < x \leq 1$

1

$$f_2(1) = \frac{1}{2} \log \frac{1}{2} + \left(1 - \frac{1}{2}\right) \log \left(1 - \frac{1}{2}\right) = 2 \left[\frac{1}{2} \log \frac{1}{2} \right]$$

For $n = 3$ (stage 3)

$$\begin{aligned} f_3(1) &= \min_{0 < x \leq 1} [x \log x + f_2(1-x)] \\ &= \min_{0 < x \leq 1} \left[x \log x + 2 \left(\frac{1-x}{2} \right) \log \left(\frac{1-x}{2} \right) \right] \end{aligned}$$

Minimum value of this function is attainable at $x = \frac{1}{3}$ so as to satisfy $0 < x \leq 1$

$$f_3(1) = \frac{1}{3} \log \frac{1}{3} + 2 \left[\frac{1}{3} \log \frac{1}{3} \right] = 3 \left[\frac{1}{3} \log \frac{1}{3} \right]$$

In general, for n stages problems

$$f_n(1) = n \left[\frac{1}{n} \log \frac{1}{n} \right]$$

Optimal policy $p_1 = p_2 = \dots = p_n = \frac{1}{n}$ for $n = m + 1$, the recursive equation is

$$\begin{aligned} f_{m-1}(1) &= \min_{0 < x \leq 1} [x \log x + f_m(1-x)] \\ &= \min_{0 < x \leq 1} \left[x \log x + m \left\{ \frac{1-x}{m} \log \frac{(1-x)}{m} \right\} \right] \\ &= \frac{1}{m+1} \log \frac{1}{m+1} + m \left\{ \frac{1}{m+1} \log \frac{1}{m+1} \right\} \\ &= (m+1) \left\{ \frac{1}{m+1} \log \frac{1}{m+1} \right\} \end{aligned}$$

Minimum of the function is attainable at $x = \frac{1}{m+1}$

The required optimal policy is

$$\left(\frac{1}{n}, \frac{1}{n}, \dots, \frac{1}{n} \right) \text{ with } f_n^0(1) = n \left(\frac{1}{n} \log \frac{1}{n} \right)$$

Example 5

Use dynamic programming to solve the problem

Minimise $Z = y_1^2 + y_2^2 + y_3^2$ subject to the constraints $y_1 + y_2 + y_3 \geq 15$ and $y_1, y_2, y_3 \geq 0$

Solution. It is a three stage problem with decision variables being y_1, y_2 and y_3

$$S_3 = y_1 + y_2 + y_3 \geq 15$$

$$S_2 = y_1 + y_2 = S_3 - y_3$$

$$S = y_1 = S_2 - y_2$$

This can be put in the following functional relationship

$$f_1(S_1) = \min_{0 \leq y_1 \leq S_1} y_1^2 = (S_2 - y_2)^2$$

$$f_1(S_1) = \min_{0 \leq y_2 \leq S_2} [y_1^2 + y_2^2] = \min_{0 \leq y_2 \leq S_2} [y_2^2 + f_1(S_1)]$$

$$f_2(S_2) = \min_{0 \leq y_2 \leq S_2} [y_1^2 + y_2^2]$$

$$f_3(S_3) = \min_{0 \leq y_3 \leq S_3} [y_1^2 + y_2^2 + y_3^2] = \min_{0 \leq y_3 \leq S_3} [y_3^2 + f_2(S_2)]$$

$$f_2(S_2) = \min_{0 \leq y_2 \leq S_2} [y_1^2 + (S_2 - y_2)^2] \text{ as } y_1^2 = (S_2 - y_2)^2$$

Since the function $[y_2^2 + (S_2 - y_2)^2]$ can attain its minimum value at $y_2 = \frac{1}{2} S_2$ so that to satisfy.

$$0 \leq y_2 \leq S_2$$

$$f_2(S_2) = \min_{0 \leq y \leq S_2} = \left(\frac{1}{2} S_2\right)^2 + \left(S_2 - \frac{1}{2} S_2\right)^2 = \frac{1}{2} S_2^2$$

$$f_3(S_3) = \min_{0 \leq y_3 \leq S_3} = [y_3^2 + f_2(S_2)] = \min_{0 \leq y_3 \leq S_3} \left[y_3^2 + \frac{1}{2} (S_3 - y_3)^2 \right]$$

$$\text{or } f_3(15) = \min_{0 \leq y_3 \leq S_3} = \left[y_3^2 + \frac{1}{2} (15 - y_3)^2 \right]$$

Since $S_3 (y_1 + y_2 + y_3) \geq 15$

The minimum value of function $\left[y_3^2 + \frac{1}{2} (15 - y_3)^2 \right]$ occurs at $y_3 = 5$

$$f_3(15) = \left[5^2 + \frac{1}{2} (15 - 5)^2 \right] = 75$$

$$S_3 = 5$$

$$S_2 = S_3 - y_3 = 15 - 5 = 10$$

$$S_1 = S_2 - y_2 = 10 - 5 = 5$$

Hence the optimal policy is (5, 10, 5) with $f_3(15) = 75$

4.0. CONCLUSION

As in summary

5.0. SUMMARY

Sequel to unit 2. About Dynamic programming, Graphical methods of solving Goal programming problem was discussed. Mathematical model were formulated and solved.

6.0.TUTOR MARKED ASSIGNMENT

1) A manufacturer produces two types of products A and B. The plant has production capacity of 500 hours a month and production of product A or B on an average requires one hour in the plant. The number of products A and B sold every month and the net profit from the sales of these products are given in the following table.

Type of product	Number sold in a month	Net Profit
A	150	
B	200	

The MD of the company has set the following goals which are arranged in order of priority

P_1 No under utilization of plant production capacity

P_2 Sell maximum possible numbers of products A and B. The MD has twice as much desire to sell product A as for product B, because the net profit from the sale of product A is twice the amount from that of product B.

P_3 Minimise overtime operation of the plant

Formulate the above as a goal programming problem and solve it

2) Use dynamic programming to solve the problem

Minimise $Z = y_1^2 + y_2^2 + y_3^2$ subject to the constraints $y_1 + y_2 + y_3 \geq 10$ and $y_1, y_2, y_3 \geq 0$

7.0. REFERENCES/FURTHER READINGS

1. Operations Research. By Prem Kumar Gupta and D.S. Hira
2. Operations Research. (Problem Solvers) By Research and Education Association.
17. Statistics and Operations Research. By Debashis Dutta
18. Operations Research By. O.T. Arowolo and G.O. Lawal

UNIT 4 TRANSPORTATION MODEL

35.0. Introduction

36.0. Objective

37.0. Main Content

3.1. Transportation Problems Defined

3.2. The General Transportation Problem

3.3. Balanced Transportation Problem

3.4. Unbalanced Transportation Problem

3.5. Method of Solution

3.6. Degeneracy and the Transportation Problem

3.7. Testing the Solution for Optimality

3.8. Solution of Unbalanced Transportation Problem

3.9. Maximization and the Transportation Techniques

38.0. Conclusion

39.0. Summary

40.0. Tutor Marked Assignment

41.0. Reference/ Further Readings

16.0 INTRODUCTION

The transportation problem is a particular form of the general linear programming problem which is usually solved by a different technique to the simplex method. This chapter describes transportation models and shows a step by step method of solution. The transportation models are used when a firm is trying to decide where to locate a new facility. Before opening a new warehouse, factory or sales office, it is a good practice to consider a number of alternatives sites. Good financial decision concerning facility location also attempt to minimize total transportation and product costs for the entire system.

17.0 OBJECTIVE

- * Understand limitations of integer programming
- * Identify the methods of integer programming
- * Formulate integer programming model
- * Solve IP problems using branch and bond method

18.0 MAIN CONTENT

3.1 Transportation Problems Defined

The typical transportation problem involves a number of sources of supply (e.g. factory) and a number of destinations (e.g. warehouses). A source or supply point is defined as having only outgoing flows, a destination or sink point is defined as having only incoming flows. The capacities or demands are assumed to be real value; as are the cost or profit coefficients.

The usual objective is to minimize the transportation cost of supplying quantities of a commodity from the source to the destination. The major requirement is that, there must be a constant transportation cost per unit. However, there are some situations when a transportation objective is to maximize. This will be discussed later.

3.2 The General Transportation Problem

The general form of a transportation problem for ' m ' sources and ' n ' destination can be represented as:

- i. A generalized network model
- ii. A transportation tableau
- iii. A linear programming model

Transportation as a Generalized Network

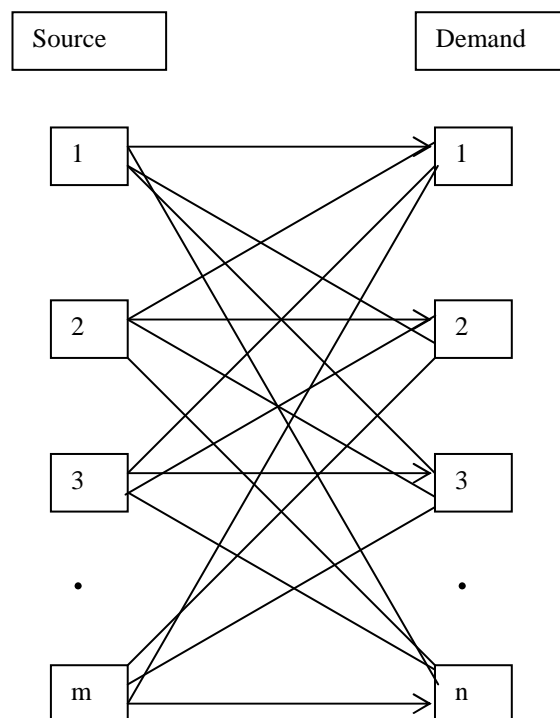

Fig. 1

Transportation Tableau

Source	Destination					Supply (s_i)
	1	2	3	...	n	
1	$\underline{c_{11}}$ x_{11}	$\underline{c_{12}}$ x_{12}	$\underline{c_{13}}$ x_{13}	...	$\underline{c_{1n}}$ x_{1n}	s_1
2	$\underline{c_{21}}$ x_{21}	$\underline{c_{22}}$ x_{22}	$\underline{c_{23}}$ x_{23}	...	$\underline{c_{2n}}$ x_{2n}	s_2
3	$\underline{c_{31}}$ x_{31}	$\underline{c_{32}}$ x_{32}	$\underline{c_{33}}$ x_{33}	...	$\underline{c_{3n}}$ x_{3n}	s_3

.
.
.
m	$\underline{c_{m1}}$	$\underline{c_{m2}}$	$\underline{c_{m3}}$...	$\underline{c_{mn}}$	s_m
	x_{m1}	x_{m2}	x_{m3}		x_{mn}	
Demand (d_i)	d_1	d_2	d_3	...	d_n	Total

Table 1

The above general transportation tableau has the following characteristics:

- i. The sources are treated as rows and destination as column.
- ii. There are $(m \times n)$ cells in the tableau.
- iii. The transportation cost, c_{ij} , from source 'i' to destination 'j' is recorded in the top right corner of each cell.
- iv. The supply from each source is listed in the last column on the right hand side.
- v. The demand from each destination is recorded at the bottom row.
- vi. The x_{ij} variable in each cell represent the number of units of product transported from source 'i' to destination 'j'.
- vii. The lower right hand corner cell reflects the total supply and the total demand.

Transportation as a Linear Programming Model

$$\text{Min } z = \sum_{i=1}^m \sum_{j=1}^n c_{ij} x_{ij} .$$

S.t:

$$\sum_{i=1}^m x_{ij} = d_j \text{ (Demand } d_j \text{ at destination } j), j = 1, 2, \dots, n .$$

$$\sum_{j=1}^n x_{ij} = s_i \text{ (Supply } s_i \text{ from source } i), i = 1, 2, \dots, m .$$

$$x_{ij} \geq 0 \text{ for all } i, j =$$

$$\sum_{i=1}^m s_i = \sum_{j=1}^n d_j \text{ (To indicate that transportation problem is balanced).}$$

However, it should be noted that for the type of algorithm to be described here; the tabular representation will be used.

3.3 Balanced Transportation Problem

This is when the total supply from all sources exactly equal total demand at all destination. This type of problem is referred to as a balanced transportation problem. It is rare to observe a balanced transportation problem in reality, however the analysis of a balanced problem is a good starting point to understanding of the transportation solution processes.

For an illustration, see the table below:

EXAMPLE 1

Consider the transportation problem with the following unit costs and capacities.

Source	Destination			Supply
	A	B	C	
1	5	1	6	200
2	8	4	3	350
3	7	9	5	170
Demand	200	300	200	

Table 2

From the table above, you will notice that the row total (i.e. supply) is exactly equal to the column total (i.e. demand), which is 720 units.

3.4 Unbalanced Transportation Problem

When the sum of the row requirement is not equal to the sum of the column requirements, the transportation problem is said to be unbalanced. There are two possibilities:

1) Over Production

If the sum of the row requirement (supply) is greater than the sum of the column requirements, (demand), the production at the factories or sources exceeds the demand at the destination, warehouses or sinks and a condition of over production exists. The transportation problem can be balanced by creating an artificial destination, warehouse or sink where the excess units are sent. This is equivalent to adding one column to the cost and distribution matrices. This additional column is given a requirement equal to difference between the sum of rows and column requirements.

For the purpose of this book, the cost coefficients will be assumed to be all zeros. Their true values depend upon the situation at hand. However, they could have positive values equal to the cost of storing the excess inventory at each destination.

For example, consider a problem with the following cost matrix with row and column requirements as an example of over production.

EXAMPLE 2

Consider the transportation problem with the following unit costs and capacities.

Plant	Warehouse			Monthly capacity
	A	B	C	
1	20	19	21	12200
2	19	22	18	2800
3	20	20	20	2500
4	21	20	19	2200
Monthly demand	7300	3500	5600	

Table 3

The over production is 3300 units. With the addition of an artificial column (destination) called “Dummy”, the

balanced transportation problem becomes:

Plant	Warehouse				Monthly capacity
	A	B	C	Dummy	
1	20	19	21	0	12200
2	19	22	18	0	2800
3	20	20	20	0	2500
4	21	20	19	0	2200
Monthly demand	7300	3500	5600	3300	

Table 4

2) Under Production

When the sum of row requirements is less than the sum of column requirements, the demand at the destinations (sinks) exceeds the production at the factories (sources) and under production exists. To balance the problem, add an artificial factory (source) with a scheduled production equal to the unsatisfied demand. Again, for the purpose of this book, the cost coefficients will be assumed to be all zeros. Their true values depend upon the situation at hand.

The following is an example of under production with the cost matrix, row and column requirement.

EXAMPLE 3

Consider the transportation problem with the following unit costs and capacities.

Source	Destination					Supply
	A	B	C	D	E	
X	100	50	90	30	130	30000
Y	90	30	70	50	110	20000
Z	95	30	75	40	120	20000
Demand	10000	12000	15000	17000	25000	

Table 5

The level of under production is 9000 units. To balance the problem, add an artificial row (factory, supply or source) with a scheduled production of 9000 units. The balanced transportation is:

Source	Destination					Supply
	A	B	C	D	E	
X	100	50	90	30	130	30000
Y	90	30	70	50	110	20000
Z	95	30	75	40	120	20000
Dummy	0	0	0	0	0	9000
Demand	10000	12000	15000	17000	25000	

Table 6

3.5 Method of Solution

As mentioned in the introduction, linear programming can be used to solve this type of problem. However, more efficient special purpose algorithm has been developed for the transportation application. As in the simplex algorithm, they involve finding an initial feasible solution and the making step by step improvements until an optimal solution is reached. Unlike the simplex method, the transportation methods are fairly simple in terms of computation.

Here, we will take a look at the following methods of solution which gives an initial feasible solution to transportation problem.

The methods are:

- i. North-west corner method;
- ii. Least cost first method;
- iii. Vogel's approximation method.

While stepping stone method and the modify improved method (MDI) are iterative technique for moving from an initial feasible solution to an optimal solution.

It must be mentioned however that before any of these method can be applied, the transportation problem must be a balanced one.

North-west Corner Method

This method advocates that allocation should be made on the basis of geographical location of the cells in the tableau. In particular, the method attaches greater importance to the cell situated at the upper left hand corner of the tableau and makes as much as possible an allocation to the cell with both the supply restriction and demand constraint taking into consideration.

The algorithm for North-west corner methods are:

- i. Exhaust the supply (source) capacity at each row before moving down to the next row.
- ii. Exhaust the demand (destination) requirements of each column before moving to the right of the next column.
- iii. Continue in the same manner until all supply has been exhausted and demand requirements have been met.

EXAMPLE 4

A firm has three factories in Lagos, Ibadan and Benin which make weekly dispatches to four depots located at Kaduna, Kano, Kebbi and Katsina. The transport cost per cost of goods dispatch along route is shown in the table below as well as the weekly quantities available from each factory and the requirement of each depot.

Transport cost / create

Storage	Demand point				Supply capacity
	Kaduna	Kano	Kebbi	Katsina	
Lagos	<u>5</u>	<u>4</u>	<u>5</u>	<u>6</u>	100
Ibadan	<u>3</u>	<u>3</u>	<u>6</u>	<u>6</u>	200
Benin	<u>2</u>	<u>5</u>	<u>7</u>	<u>8</u>	400
Demand	200	100	150	250	

Table 7

How should the product be allocated to the depots? Use the North-west corner method for the initial allocation.

SOLUTION

Using the procedure describe above for the North-west corner method. The table below shows the initial allocation.

Storage	Demand point				Supply capacity
	Kaduna	Kano	Kebbi	Katsina	
Lagos	<u>5</u> 100(1)	<u>4</u>	<u>5</u>	<u>6</u>	100
Ibadan	<u>3</u> 100(2)	<u>3</u> 100(3)	<u>6</u>	<u>6</u>	200
Benin	<u>2</u>	<u>5</u>	<u>7</u> 150(4)	<u>8</u> 250(5)	400
Demand	200	100	150	250	

Table 8

Note

The numbers in the table represent deliveries and the numbers in the brackets (1), (2), etc. represent the order of allocation (distribution). The number in the top right corner of each cell represent unit cost of transportation.

Transportation Cost for this Initial Allocation in using North-west Corner Method

Route	Unit shipped	×	Cost per unit (#)	=	Total cost (#)
From To					
Lagos Kaduna	100	×	5	=	500
Ibadan Kaduna	100	×	3	=	300
Ibadan Kano	100	×	3	=	300
Benin Kebbi	150	×	7	=	1050
Benin Katsina	250	×	8	=	2000
					<u>4150</u>

The total cost from North-west corner method is #4,150 for the initial feasible solution.

Least Cost Method

The method advocates that allocation should be based on minimum cost of transportation rule / criterion. It says that the first allocation must be made to the cell with the most minimum cost of transportation per unit. In other words, we look at the scheduled of the transport cell and identify the most minimum.

After identifying the cell with the least transportation cost, we next make maximum allocation to the cell without violating both supply and demand restriction.

To demonstrate the use of least cost first method, consider the problem of Example 4.

Storage	Demand point				Supply capacity
	Kaduna	Kano	Kebbi	Katsina	
Lagos	<u>5</u>	<u>4</u>	<u>5</u> 100(3)	<u>6</u>	100
Ibadan	<u>3</u>	<u>3</u> 100(2)	<u>6</u> 50(4)	<u>6</u> 50(5)	50
Benin	<u>2</u> 200(1)	<u>5</u>	<u>7</u>	<u>8</u> 200(6)	400
Demand	200	0	50	250	

Table 9

The transportation cost for this initial allocation is:

Route	Unit shipped	×	Cost per unit (#)	=	Total cost (#)
From To					
Benin Kaduna	200	×	2	=	400
Ibadan Kano	100	×	3	=	300
Lagos Kebbi	100	×	5	=	500
Ibadan Kebbi	50	×	6	=	300
Ibadan Katsina	50	×	6	=	300
Benin Katsina	200	×	8	=	1600
					<hr/> 3400 <hr/>

The total cost from least cost first method is #3,400 for the initial feasible solution.

Note that allocation 5 can be before 4 and vice versa.

So, for alternative solution, allocation 5 will be performed before.

Alternative Solution

Storage	Demand point				Supply capacity
	Kaduna	Kano	Kebbi	Katsina	
Lagos	<u>5</u>	<u>4</u>	<u>5</u> 100(3)	<u>6</u>	100
Ibadan	<u>3</u>	<u>3</u> 100(2)	<u>6</u>	<u>6</u> 100(4)	50
Benin	<u>2</u> 200(1)	<u>5</u>	<u>7</u> 50(5)	<u>8</u> 150(6)	150
Demand	200	0	500	250	

Table 10

The transportation cost for this initial allocation is:

Route		Unit shipped	×	Cost per unit (#)	=	Total cost (#)
From	To					
Benin	Kaduna	200	×	2	=	400
Ibadan	Kano	100	×	3	=	300
Lagos	Kebbi	100	×	5	=	500
Ibadan	Katsina	100	×	6	=	600
Benin	Kebbi	50	×	7	=	350
Benin	Katsina	150	×	8	=	1200
						3350

Vogel's Approximation Method

In his consideration, Vogel felt that rather than basing allocation on least cost alone; the penalty or opportunity cost one we pay by taking a wrong decision would have been an additional criterion for allocation. Hence, he felt a combination of least cost and opportunity cost would be better for allocation purpose and thus, he introduce the idea of row and column penalties or opportunity cost. The row or column penalty cost is computed by identifying the two (2) least cost in each row and each column and then find the difference.

Whatever result obtained is taking as penalty for that row or column. If two costs in a row or column are tied for the rank of least cost, the penalty is zero.

The algorithms for Vogel's approximation are:

- i. Determine the penalty for each row and column.
- ii. After the penalties have been calculated for all rows and columns, locate the greatest; whether a row or a column penalty and place the variable in the cell that has the least cost in the row or column with the greatest penalty. The value of the variable is set equal to the smaller of the row and column requirements corresponding to the variable being brought into the solution. The row or column whose requirement is satisfied is deleted from further consideration and the requirement of the other (row or column) is reduced by the value assigned to the variable entering the solution.
- iii. If a row requirement has been satisfied, the column penalties must be recomputed because the elements of the cost matrix corresponding to the row deleted are no longer considered in the calculation of column penalties.
- iv. If a column requirement has been satisfied, the row penalties must be recomputed because the element of the cost matrix corresponding to the column deleted are no longer considered in the calculation of row penalties.
- v. If a tie develops between two or more row or column penalties, select the least cost cell among these two or more rows and columns. If however, a further tie occurs among the least cost cell, then, select arbitrary (using good judgment) which among the tied cost cell will be used.
- vi. Repeat steps *I* through *VI* until the solution is completed.

Although, it cannot be proved mathematically that Vogel's method yields a near optimal solution. Frequently, the North-west corner method and the least cost first method yields an initial solution which is far from optimal.

Application of this method will be demonstrated with the problem of Example 4.

EXAMPLE 6

Storage	Demand points				Supply capacity
	Kaduna	Kano	Kebbi	Katsina	
Lagos	<u>5</u>	<u>4</u>	<u>5</u>	<u>6</u>	100
Ibadan	<u>3</u>	<u>3</u>	<u>6</u>	<u>6</u>	200
Benin	<u>2</u>	<u>5</u>	<u>7</u>	<u>8</u>	400
Demand	200	100	150	250	

Table 11

SOLUTION

Cycle 1

Step 1: Compute the row and column penalties on the cost matrix.

Storage	Demand points				Row penalties
	(200) Kaduna	(100) Kano	(150) Kebbi	(250) Katsina	
Lagos (100)	<u>5</u>	<u>4</u>	<u>5</u>	<u>6</u>	1
Ibadan (200)	<u>3</u>	<u>3</u>	<u>6</u>	<u>6</u>	0
Benin (400)	<u>2</u>	<u>5</u>	<u>7</u>	<u>8</u>	3 ←
Column penalties	1	1	1	0	

Table 12

The greatest penalty is 3 (marked with arrow). This occurs in the 3rd row (i.e. Benin row). Therefore, the first variable will be entered in the 3rd row of the cell with least cost in this row.

Step 2

With reference to the distribution table of cycle 1, we assign a maximum value from row 3 (Benin) to column 1 (Kaduna). Here, demand is 200 units and supply is 400 units, so that maximum value is 200 units with excess supply of 200 units to be shipped to another destination. Thus, we have:

Storage	Demand points			
	(0) Kaduna	(100) Kano	(150) Kebbi	(250) Katsina
Lagos (100)	<u>5</u>	<u>4</u>	<u>5</u>	<u>6</u>
Ibadan (200)	<u>3</u>	<u>3</u>	<u>6</u>	<u>6</u>
Benin (200)	(1) <u>2</u> 200	<u>5</u>	<u>7</u>	<u>8</u>

Table 13

Note that Kaduna (i.e. column 1) demand has been satisfied. Therefore, it is eliminated from further consideration. Rows 1, 2 and 3 penalties must be recomputed.

Cycle 2

Step 1: Compute new row penalties.

Storage	Demand points				Row penalties
	(0) Kaduna	(100) Kano	(150) Kebbi	(250) Katsina	
Lagos (100)	<u>5</u>	<u>4</u>	<u>5</u>	<u>6</u>	1
Ibadan (200)	<u>3</u>	<u>3</u>	<u>6</u>	<u>6</u>	3 ←
Benin (200)	(1) <u>2</u> 200	<u>5</u>	<u>7</u>	<u>8</u>	2
Column penalties	-	1	1	0	

Table 14

The greatest penalty is 3 (marked with arrow). This occurs in the 2nd row (i.e. Ibadan). Therefore, the second variable will be entered in the 2nd row of the cell with least cost in this row.

Step 2

With reference to the distribution table of cycle 2 , we have two least cost in the 2nd row (i.e. Ibadan). They are: column1 (Kaduna) and column 2 (Kano). But, the demand at column1 (Kaduna) has been satisfied which now leave us with column 2 (Kano) only. We now assign a maximum value from Row 2 (Ibadan) to column 2 (Kano). Here, demand is 100units and supply is 200 units, so the maximum value is 100 units (demand) with excess supply of 100 units to be shipped to another destination. Thus, we have:

Storage	Demand points			
	(0) Kaduna	(0) Kano	(150) Kebbi	(250) Katsina
Lagos (100)	<u>5</u>	<u>4</u>	<u>5</u>	<u>6</u>
Ibadan (100)	<u>3</u>	(2) <u>3</u> 100	<u>6</u>	<u>6</u>
Benin (200)	(1) <u>2</u> 200	<u>5</u>	<u>7</u>	<u>8</u>

Table 15

Note that Kano (i.e. column 2) demand has been met. Hence, we eliminated it from further consideration.

Rows1, 2 and 3 penalties must be recomputed.

Cycle 3

Step 1: Compute new row penalties.

Storage	Demand points				Row penalties
	(0) Kaduna	(0) Kano	(150) Kebbi	(250) Katsina	
Lagos (100)	<u>5</u>	<u>4</u>	<u>5</u>	<u>6</u>	1 ←
Ibadan (100)	<u>3</u>	(2) <u>3</u> 100	<u>6</u>	<u>6</u>	0
Benin (200)	(1) <u>2</u> 200	<u>5</u>	<u>7</u>	<u>8</u>	1 ←
Column penalties	-	-	1 ↑	0	

Table 16

A tie has occur here; the penalties in column 3, rows 1 and 3.

We now look at the cells in each of these column and rows altogether and select the cell with the least cost.

This occurs in row 1(Lagos) intersection column 3 (Kebbi).

Therefore, the third variable will be entered in the 1st row, 3rd column.

Step 2

With reference to the distribution table of cycle 3, the third variable is entered in the 1st row (Lagos), 3rd column (Kebbi). The demand here is 150 units and supply is 100 units. We assign 100 units with excess demand of 50 units to be supplied from another source. Thus, we have:

Storage	Demand points			
	(0) Kaduna	(0) Kano	(50) Kebbi	(250) Katsina
Lagos (0)	<u>5</u>	<u>4</u>	(3) <u>5</u> 100	<u>6</u>
Ibadan (100)	<u>3</u>	(2) <u>3</u> 100	<u>6</u>	<u>6</u>
Benin (200)	(1) <u>2</u> 200	<u>5</u>	<u>7</u>	<u>8</u>

Table 17

Note that Lagos (row 1) supply has been exhausted. We eliminated this row from further consideration.

Columns 3 and 4 penalties must be recomputed.

Cycle 4

Step 1: Compute new column penalties.

Storage	Demand points				Row penalties
	(0) Kaduna	(0) Kano	(50) Kebbi	(250) Katsina	
Lagos (0)	<u>5</u>	<u>4</u>	(3) <u>5</u> 100	<u>6</u>	-
Ibadan (100)	<u>3</u>	(2) <u>3</u> 100	<u>6</u>	<u>6</u>	0
Benin (200)	(1) <u>2</u> 200	<u>5</u>	<u>7</u>	<u>8</u>	1
Column penalties	-	-	1	2 ↑	

Table 18

The greatest penalty is 2 (marked with arrow). This occurs in the 4th column (Katsina). Therefore, the fourth variable will be entered in the fourth column of the cell with least cost in this column.

Step 2

With reference to the distribution table of cycle 4, the 4th variable is entered in the 4th column, 2nd row.

The demand here is 250 units and supply is 100 units. We assign 100 units with excess demand of 150 units to be supplied from another source. Thus, we have:

Storage	Demand points			
	(0) Kaduna	(0) Kano	(50) Kebbi	(150) Katsina
Lagos (0)	<u>5</u>	<u>4</u>	(3) <u>5</u> 100	<u>6</u>
Ibadan (0)	<u>3</u>	(2) <u>3</u> 100	<u>6</u>	(4) <u>6</u> 100
Benin (200)	(1) <u>2</u> 200	<u>5</u>	<u>7</u>	<u>8</u>

Table 19

Note that Ibadan (row 2) supply has been exhausted. We eliminated this row from further consideration. Supply can only be from Benin (row 3) at this stage. Demands are from Kebbi (columns 3) and Katsina (columns 4) only. Based on this, we do not need to calculate penalties anymore. We now allocate to the least cost first. With reference to table in step 2 of cycle 4, we supply from Benin (row 3) to Kebbi (columns 3) and Katsina (columns 4) 50 units and 150 units respectively. Thus, we have the final table which looks like this:

Storage	Demand points			
	(0) Kaduna	(0) Kano	(0) Kebbi	(0) Katsina
Lagos (0)	<u>5</u>	<u>4</u>	(3) <u>5</u> 100	<u>6</u>
Ibadan (0)	<u>3</u>	(2) <u>3</u> 100	<u>6</u>	(4) <u>6</u> 100
Benin (0)	(1) <u>2</u> 200	<u>5</u>	<u>7</u> 50	(5) <u>8</u> 150

Table 20

Transportation cost for this initial allocation is:

Route		Unit	×	Cost	=	Total cost
From	To	shipped		per unit		(#)
Lagos	Kebbi	100	×	5	=	500
Ibadan	Kano	100	×	3	=	300
Ibadan	Katsina	100	×	6	=	600
Benin	Kaduna	200	×	2	=	400
Benin	Kebbi	50	×	7	=	350
Benin	Katsina	150	×	8	=	1200
						3,350

We should note here that, the methods (i.e. North-west corner, Least cost first and Vogel's approximation) that we have just discuss are only meant for the initial allocation.

They might not give us the optimal allocation. In most cases, they do not. This now lead us to getting the optimal solution; but, before then, we shall discuss degeneracy.

3.6 Degeneracy and the Transportation Problem

The total number of allocation to be made in a transportation problem should be equal to one less than the number of rows added to the number of column i.e. Total number of allocation = Number of rows + Number of columns – 1.

On the occasions, the number of allocations turns out to be less than this (i.e. rows + columns – 1). The condition is known as degeneracy.

Dealing with Degeneracy

If degeneracy occurs in the allocation of a transportation problem, then it is necessary to make one or more zero allocations to routes to bring up the number of allocation to ROWS + COLUMNS – 1.

3.7 Testing the Solution for Optimality

By optimality test, we want to check the initial feasible solution obtained representing the minimum cost possible. This is done by

calculating what are known as ‘shadow costs’ (i.e. an imputed cost of not using a particular route) and comparing these with the real transport costs to see whether a change of allocation is desirable. This is done as follows with reference to the initial feasible solution of the table below:

Source	Demand				Supply
	D_1	D_2	D_3	D_4	
S_1	$\frac{8}{4}$	$\frac{6}{6}$	$\frac{10}{6}$	$\frac{15}{10}$	4
S_2	$\frac{12}{2}$	$\frac{9}{6}$	$\frac{7}{6}$	$\frac{8}{10}$	12
S_3	$\frac{13}{2}$	$\frac{13}{6}$	$\frac{10}{2}$	$\frac{7}{10}$	14
Demand	6	6	8	10	

Table 21

Step 1

Check that number of allocation is ROWS + COLUMN – 1.

Else, treat as degeneracy.

For this solution; Rows = 3 and Column = 4 .

∴ Number of allocation = 3 + 4 – 1 = 6, which is the same as the number of allocation made.

Step 2

Calculate a nominal ‘Sending’ and ‘Receiving’ cost for each occupied cell by making assumption that, the transport cost per unit is capable of being split between Sending and Receiving costs i.e.

$$S_1 + D_1 = 8$$

$$S_2 + D_2 = 9$$

$$S_2 + D_3 = 7$$

$$S_3 + D_1 = 13$$

$$S_3 + D_3 = 10$$

$$S_3 + D_4 = 7$$

Where S_1, S_2 and S_3 represent sending cost from source S_1, S_2 and S_3 and D_1, D_2, D_3 and D_4 represent receiving cost at destination D_1, D_2, D_3 and D_4 .

By convention, the first source is assigned the value of zero i.e. $S_1 = 0$ and this value is substituted in the first equation and then all the other values can be obtained thus:

$$D_1 = 8, D_2 = 7, D_3 = 5, D_4 = 2.$$

Using these values, the shadow costs of the unoccupied cells can be calculated. The unoccupied cells are: $S_1D_2, S_1D_3, S_1D_4,$

S_2D_1, S_2D_4 and S_3D_2 .

Therefore;

Cell	Shadow cost
S_1D_2 :	$S_1 + D_2 = 0 + 7 = 7$
S_1D_3 :	$S_1 + D_3 = 0 + 5 = 5$
S_1D_4 :	$S_1 + D_4 = 0 + 2 = 2$
S_2D_1 :	$S_2 + D_1 = 2 + 8 = 10$
S_2D_4 :	$S_2 + D_4 = 2 + 2 = 4$
S_3D_2 :	$S_3 + D_2 = 5 + 7 = 12$

These computed shadow costs are compared with the actual transport costs (from table ..). Where the ACTUAL costs are less than SHADOW costs, overall costs can be reduced by allocating units into that cell.

By comparison, we mean the difference between Actual cost and Shadow cost. This difference is sometimes referred to as the improvement index i.e.

$$\text{IMPROVEMENT INDEX} = \text{ACTUAL COST} - \text{SHADOW COST.}$$

Cell	Actual cost	Shadow cost	Improvement index
S_1D_2 :	6	7	-1
S_1D_3 :	10	5	5
S_1D_4 :	15	2	13
S_2D_1 :	12	10	2
S_2D_4 :	8	4	4
S_3D_2 :	13	9	4

The meaning of this is that, if all the improvement indices computed is greater than or equal to zero, an optimal solution has been reached. If not, it is possible to improve the current solution and decrease total transportation costs. In other words, if any of the indices is negative, an improved solution is possible. If however, there are more than one negative improvement index, our strategy would be to choose the route (unused route) with the largest negative index. Situations do arise when the largest negative index is not unique. Now, let us continue with our illustration example. The total cost could be reduced by #1 for every unit that can be transferred into cell S_1D_2 . As there is a cost reduction that can be made, the solution in Table 21 is not optimum.

Step 3

Make the maximum possible allocation of deliveries into the cell with the (largest) negative improvement index using occupied cells i.e. S_1D_2 from step 2. The number that can be allocated is governed by the need to keep within the row and column totals. This is done as follows:

Source	Demand				Supply
	D_1	D_2	D_3	D_4	
S_1	(-) $\underline{8}$ 4	(+) $\underline{6}$	$\underline{10}$	$\underline{15}$	4
S_2	$\underline{12}$	(-) $\underline{9}$ 6	(+) $\underline{7}$ 6	$\underline{8}$	12
S_3	(+) $\underline{13}$ 2	$\underline{13}$	(-) $\underline{10}$ 2	$\underline{7}$ 10	14
Demand	6	6	8	10	

Table 22

Table 22 is a reproduction of Table 21 with a number of + and – inserted. These were inserted for the following reasons:

Cell S_1D_2 : + indicates a transfer IN as indicated in step 2.

Cell S_1D_1 : – indicates a transfer OUT to maintain Row S_1 total.

Cell S_2D_2 : – indicates a transfer OUT to maintain Row column D_2 total.

Cell S_2D_3 : + indicates a transfer IN to maintain Row S_2 total.

Cell S_3D_1 : + indicates a transfer IN to maintain column D_1 total.

Cell S_3D_3 : – indicates a transfer OUT to maintain Row S_3 and column D_3 balance.

The maximum number that can be transferred into cell S_1D_2 is the lowest number in the minus cells i.e. cells S_1D_1 , S_2D_2 and S_3D_3 which is 2 units.

∴ 2 units is transferred in the + and – sequence described above resulting in the following table:

Source	Demand				Supply
	D_1	D_2	D_3	D_4	
S_1	<u>8</u> 2	<u>6</u> 2	<u>10</u>	<u>15</u>	4
S_2	<u>12</u>	<u>9</u> 4	<u>7</u> 8	<u>8</u>	12
S_3	<u>13</u> 4	<u>13</u>	<u>10</u>	<u>7</u> 10	14
Demand	6	6	8	10	

Table 23

The total cost of this solution is:

$$\begin{aligned}
 \text{Cell } S_1D_1 & 2 \text{ units} \times \# 8 = \# 16 \\
 \text{Cell } S_1D_2 & 2 \text{ units} \times \# 6 = \# 12 \\
 \text{Cell } S_2D_2 & 4 \text{ units} \times \# 9 = \# 36 \\
 \text{Cell } S_2D_3 & 8 \text{ units} \times \# 7 = \# 56 \\
 \text{Cell } S_3D_1 & 4 \text{ units} \times \# 13 = \# 52 \\
 \text{Cell } S_3D_4 & 10 \text{ units} \times \# 7 = \# \underline{70} \\
 & \# \underline{242}
 \end{aligned}$$

The new total cost is # 2 less than the total cost established in step 1. This is the result expected because it was established in step 2 that #1 would be saved for every units we were able to transfer to cell S_1D_2 and we were able to transfer 2 units only. Note: Always commence the (+) and (-) sequence with a (+) in the cell indicated by the improvement index (actual cost – shadow cost) calculation. Then, put a (-) in the occupied cell in the same row which has an occupied cell in its column. Proceed until a (-) appears in the same column as the original (+).

Step 4

Repeat step 2 i.e. check that solution represents minimum cost (optimal). Each of the process in step 2 are repeated using the latest solution (Table 23) as a basis, thus:

Nominal dispatch and reception costs for each occupied cell.

$$S_1 + D_1 = 8$$

$$S_1 + D_2 = 6$$

$$S_2 + D_2 = 9$$

$$S_2 + D_3 = 7$$

$$S_3 + D_1 = 13$$

$$S_3 + D_4 = 7$$

Setting S_1 at zero, the following values are obtained:

$$D_1 = 8, D_2 = 6, D_3 = 4, D_4 = 2, S_1 = 0, S_2 = 3, S_3 = 5.$$

Using these values, the shadow costs of the unoccupied cells are calculated. The unoccupied cells are: $S_1D_3, S_1D_4, S_2D_1, S_2D_4, S_3D_2$ and S_3D_3 .

Cell	Shadow cost
S_1D_3 :	$S_1 + D_3 = 0 + 4 = 4$
S_1D_4 :	$S_1 + D_4 = 0 + 2 = 2$
S_2D_1 :	$S_2 + D_1 = 3 + 8 = 11$
S_2D_4 :	$S_2 + D_4 = 3 + 2 = 5$
S_3D_2 :	$S_3 + D_2 = 5 + 6 = 11$

$$S_3D_3: \quad S_3 + D_3 = 5 + 4 = 9$$

The computed shadow costs are compared with actual costs to see if any reduction in cost is possible.

Cell	Actual cost	–	Shadow cost	=	Improvement index
S_1D_3	10	–	4	=	+6
S_1D_4	15	–	2	=	+13
S_2D_1	12	–	1	=	+11
S_2D_4	8	–	5	=	+3
S_3D_2	13	–	1	=	+12
S_3D_3	10	–	9	=	+1

It will be seen that all the ... are positive, therefore no further cost reduction is possible and optimum has been reached.

Optimum Solution

2 units	$S_1 \rightarrow D_1$
2 units	$S_1 \rightarrow D_2$
4 units	$S_2 \rightarrow D_2$
8 units	$S_2 \rightarrow D_3$
4 units	$S_3 \rightarrow D_1$
10 units	$S_3 \rightarrow D_4$

This solution is shown in the following tableau:

	D_1	D_2	D_3	D_4
S_1	2	2		
S_2		4	8	
S_3	4			10

Table 24

Note

In this example, only one iteration was necessary to produce an optimum solution mainly because a good initial solution was chosen. The principles explained above would, of course, be equally suitable for many iterations.

The total cost of this solution is:

		#	#	
Cell S_1D_1	4 units	\times	8	= 32
Cell S_2D_2	6 units	\times	9	= 54
Cell S_2D_3	6 units	\times	7	= 42
Cell S_3D_1	2 units	\times	13	= 26
Cell S_3D_4	2 units	\times	10	= 20
Cell S_4D_4	10 units	\times	7	= <u>70</u>
				<u>244</u>

3.8 Solution of Unbalanced Transportation Problem

Unbalanced transportation problem are solved in the same way a balanced transportation problem is handled. The method of finding an initial solution and improving on the solution by calculating Shadow cost and Actual cost are the same.

The only difference is the order in which the allocations are made. Usually, irrespective of whether you have a dummy row or column, allocation are first made to real cells according to the rules of the method of solution in used. It is after the allocation of the real cells have been taking care of, that the excess supply are allocated to the dummy column cell or excess demand allocated to dummy row cell.

EXAMPLE 5

A company presently operates three manufacturing plants that distribute a product to four warehouses. Currently, the capacity of the plants and the demands of the warehouses are stable. These are listed with the unit shipping costs in the following table.

Find the optimal distribution plan for the company.

Plants	Warehouses				Monthly capacity
	<i>A</i>	<i>B</i>	<i>C</i>	<i>D</i>	
<i>X</i>	<u>3</u>	<u>16</u>	<u>9</u>	<u>2</u>	40
<i>Y</i>	<u>1</u>	<u>9</u>	<u>3</u>	<u>8</u>	20
<i>Z</i>	<u>4</u>	<u>5</u>	<u>2</u>	<u>5</u>	50
Monthly demand	25	25	42	8	110 100

Table 25

SOLUTION

Step 1

Add a DUMMY destination to Table 25 with a zero transport costs and a requirement equal to the surplus availability.

\therefore Dummy requirement = $110 - 100 = 10$ products

Plants	Warehouses					
	<i>A</i>	<i>B</i>	<i>C</i>	<i>D</i>	Dummy	
<i>X</i>						40
<i>Y</i>						20
<i>Z</i>						50
	25	25	42	8	10	

Step 2

Now, that the quantity available equals the quantity required (because of the insertion of the dummy), we then select one of the methods for initial feasible solution.

For the purpose of this book, the three methods described in this book will be demonstrated.

Hence, an initial feasible solution for

i. North-west Corner Method

Plants	Warehouses					
	A	B	C	D	Dummy	
X	<u>3</u> 25(1)	<u>16</u> 15(2)	<u>9</u>	<u>2</u>	<u>0</u>	40
Y	<u>1</u>	<u>9</u> 10(3)	<u>3</u> 10(4)	<u>8</u>	<u>0</u>	20
Z	<u>4</u>	<u>5</u>	<u>2</u> 32(5)	<u>5</u> 8(6)	<u>0</u> 10(7)	50
	25	25	42	8	10	

The numbers in the table represent the allocations made and the numbers in the brackets represent the sequence they were inserted based on the top left corner (North-west corner) necessity to maintain row/column totals. The residue of 10 was allocated to the dummy.

The costs of this allocation are:

		#	#	
X → A	25 units	×	3	= 75
X → B	15 units	×	16	= 240
Y → B	10 units	×	9	= 90
Y → C	10 units	×	3	= 30
Z → C	32 units	×	2	= 64
Z → D	8 units	×	5	= 40
Z → Dummy	10 units	×	0	= 0
				<u>539</u>

ii. Least Cost First Method

Plants	Warehouses	
--------	------------	--

	<i>A</i>	<i>B</i>	<i>C</i>	<i>D</i>	Dummy	
<i>X</i>	5(4)	17(6)		8(3)	10(7)	40
<i>Y</i>	20(1)					20
<i>Z</i>		8(5)	42(2)			50
	25	25	42	8	10	

The numbers in the table represent the allocations made and the numbers in the brackets represent the sequence they were inserted based on lowest cost and the necessity to maintain row/column totals. The residue of 10 was allocated to the dummy.

The costs of this allocation are:

		#	#	
$X \rightarrow A$	5 units	$\times 3$	$= 15$	
$X \rightarrow B$	17 units	$\times 16$	$= 272$	
$X \rightarrow D$	8 units	$\times 2$	$= 16$	
$X \rightarrow \text{Dummy}$	10 units	$\times 0$	$= 0$	
$Y \rightarrow A$	20 units	$\times 1$	$= 20$	
$Z \rightarrow B$	8 units	$\times 5$	$= 40$	
$Z \rightarrow C$	42 units	$\times 2$	$= 84$	
				<u>447</u>

iii. Vogel's Approximation Method

Plants	Warehouses					
	<i>A</i>	<i>B</i>	<i>C</i>	<i>D</i>	Dummy	
<i>X</i>	25(3)			8(2)	7(7)	
<i>Y</i>			17(5)		3(6)	
<i>Z</i>		25(1)	25(4)			

The numbers in the table represent the allocations made and the numbers in the brackets represent the sequence they were inserted based on the penalties (greatest) and lowest cost in the row/column penalty selected necessity to maintain row/column totals. The residue of 10 was allocated partially to the dummies in row X and Y respectively.

The costs of this allocation are:

		#	#	
$X \rightarrow A$	25 units	$\times 3$	$=$	75
$X \rightarrow D$	8 units	$\times 2$	$=$	16
$X \rightarrow \text{Dummy}$	7 units	$\times 0$	$=$	0
$Y \rightarrow C$	17 units	$\times 3$	$=$	51
$Y \rightarrow \text{Dummy}$	3 units	$\times 0$	$=$	0
$Z \rightarrow B$	25 units	$\times 5$	$=$	125
$Z \rightarrow C$	25 units	$\times 2$	$=$	<u>50</u>
				<u>317</u>

3.9 Maximization and the Transportation Techniques

Although, transportation problems are usually minimizing problems, on occasions, problems are framed so that the objective is to make the allocations from sources to destinations in a manner which maximizes contribution or profit. These problems are dealt with relatively easily as follows.

Initial Allocation

a) North-west Corner Method

The procedure is exactly the same as that of minimization problem, because allocation is based on geographical location.

b) Least Cost First Method

For a maximization problem, this method will now be known as the greatest profit/contribution first method. The initial feasible allocation is made on basis of maximum profit/contribution first, then next highest and so on.

c) Vogel's Approximation

For a maximization problem, the penalty is the difference between the two greatest profit/contribution in rows/columns. Then select the least penalty and allocate to the cell with the greatest profit/contribution of the row/column with the least penalty selected.

Optimality Test

For optimum, the difference between the actual and the shadow profit/contribution for the unused routes should be ALL NEGATIVE. If not, make allocation into cell with the GREATEST positive improvement index.

EXAMPLE 6 (Maximization Problem)

A ladies fashion shop wishes to purchase the following quantities of winter dresses:

Dress size	<i>I</i>	<i>II</i>	<i>III</i>	<i>IV</i>
Quantity	100	200	450	150

Three manufacturers are willing to supply dresses. The quantities given below are the maximum they are able to supply of any given combination of orders for dresses:

Manufacturer	<i>A</i>	<i>B</i>	<i>C</i>
Total quantity	150	450	250

The shop expects the profit per dress to vary with the manufacturer as given below:

Manufacturer	Sizes			
	<i>I</i>	<i>II</i>	<i>III</i>	<i>IV</i>
<i>A</i>	#2.50	#4.00	#5.00	#2.00
<i>B</i>	#3.00	#3.50	#5.50	#1.50
<i>C</i>	#2.00	#4.50	#4.50	#2.50

You are required to:

- Use the transportation technique to solve the problem of how the orders should be placed on the manufacturers by the fashion shop in order to maximize profit and,
- Explain how you know that there is no further improvement possible, showing your workings.

SOLUTION

a) The total requirements of the shop are:

$$100 + 200 + 450 + 150 = 900 \text{ dresses,}$$

but the total availability is only

$$150 + 450 + 250 = 850 \text{ dresses.}$$

Accordingly, a DUMMY manufacturer capable of providing

50 dresses must be included so that the table balances. The

DUMMY will be given zero profit per dress. In this example,

the initial allocation is made to give maximum profit and this results in the following table.

Manufacturer	Sizes				Quantity available
	<i>I</i>	<i>II</i>	<i>III</i>	<i>IV</i>	
A	(3) $\frac{2.5}{100}$	$\frac{4}{}$	$\frac{5}{}$	(4) $\frac{2}{50}$	150
B	$\frac{3}{}$	$\frac{3.5}{}$	(1) $\frac{5.5}{50}$	$\frac{1.5}{}$	450
C	$\frac{2}{}$	(2) $\frac{4.5}{200}$	$\frac{4.5}{}$	(3) $\frac{2.5}{50}$	250
Dummy	$\frac{0}{}$	$\frac{0}{}$	$\frac{0}{}$	(5) $\frac{0}{50}$	50
Quantity required by shop	100	200	450	150	900
					900

Table 26

Note

- The top right hand figure in each square represents the actual profits as given in the question.
- The number in the middle of each square represents the allocation of dress sizes to manufacturers and the small bracket number represents the sequence of allocation e.g. Cell B/III shows 450(1) i.e. an allocation of 450 dresses made first because it has the highest profit per dress, #5.50
- It will be seen that six allocations have been made. It will be recalled that a DEGENERATE situation exists if the number of allocations is less than (number of column + number of rows – 1). A DEGENERATE situation exists in this example because there should be 7 allocations i.e.

(4 + 4 – 1) but only 6 have been made. Accordingly, a zero allocation must be made and so that the shadow profits can be calculated. Cell A/III will be deemed to be occupied with a zero allocation.

- d. As stated, the zero allocation must be made so that the shadow profits can be calculated. Shadow profits can be calculated when there is a linkage in the shadow profit calculations. It will be seen from the Table 26 that there is no overlapping allocation with Cell B/III from the A row. Accordingly, the zero allocation is made in Cell A/III, so Cell B/III can be evaluated. If, for example, the zero allocation had been made in Cell A/II, Cell B/III could be have been evaluated because neither B nor III was linked.

The next step is to test the initial allocation for optimality by calculating the shadow profits and comparing these with actual profits to see whether any improvement to the initial allocation can be made.

Shadow Profit Calculation

Occupied Cells

Cell	<i>A / I</i>	=	#2.5 profit	
Cell	<i>A / III</i>	=	#5 profit	(i.e. the zero allocation cell)
Cell	<i>A / IV</i>	=	#2 profit	
Cell	<i>B / III</i>	=	#5.5 profit	
Cell	<i>C / II</i>	=	#4.5 profit	
Cell	<i>C / IV</i>	=	#2.5 profit	
Cell	Dummy/ <i>IV</i>	=	0	

Setting $A = 0$, the following values can be calculated:

$A = 0$, $B = 0.5$, $C = 0.5$, Dummy = -2, $I = 2.5$, $II = 4$, $III = 5$, $IV = 2$.

These values are used to calculate the shadow profits of the unused routes i.e.

Cell	<i>A / I</i>	=	#4
	<i>B / I</i>	=	#3
	<i>B / II</i>	=	#4.5
	<i>C / I</i>	=	#3
	<i>C / III</i>	=	#5.5
	Dummy/ <i>I</i>	=	#0.5
	Dummy/ <i>II</i>	=	#2
	Dummy/ <i>III</i>	=	#3

The shadow profits are compared with the actual profits resulting in the following table.

Manufacturer	Sizes				Quantity available
	<i>I</i>	<i>II</i>	<i>III</i>	<i>IV</i>	
<i>A</i>	<u>2.5</u> 100	<u>4</u> <u>4</u> <u>0</u>	<u>5</u> 0	<u>2</u> 50	150
<i>B</i>	<u>3</u> <u>3</u> <u>0</u>	<u>4.5</u> <u>3.5</u> <u>-1.0</u>	<u>5.5</u> 450	<u>2.5</u> <u>-1.0</u>	450
<i>C</i>	<u>3</u> <u>2</u> <u>-1.0</u>	<u>4.5</u> 200	<u>5.5</u> <u>4.5</u> <u>-1.0</u>	<u>2.5</u> 50	250
Dummy	<u>0.5</u> <u>0</u> <u>-0.5</u>	<u>2</u> <u>0</u> <u>-2.0</u>	<u>3</u> <u>0</u> <u>-3</u>	<u>0</u> 50	50
Quantity required by shop	100	200	450	150	900
					900

Table 27

Notes

- The top right hand figure in each square represents actual profit.
- The top left hand figure in each square represents the shadow profit as calculated.
- The bottom right hand figures in each square are the differences between actual and shadow profits.
- A study of the profit differences shows that the initial allocation is optimum.

The allocations which yield maximum profit are:

Manufacturer <i>A</i>	100 size <i>I</i> Dresses	Profit	=	#250
	50 size <i>IV</i> Dresses	Profit	=	#100
Manufacturer <i>B</i>	450 size <i>III</i> Dresses	Profit	=	#2,475
Manufacturer <i>C</i>	200 size <i>II</i> Dresses	Profit	=	#900
	50 size <i>IV</i> Dresses	Profit	=	<u>#125</u>
		Total Profit	=	<u>#3,850</u>

- b) No improvement to this profit is possible because of the Actual/shadow profit comparisons given in Table 27. However, where there is a zero difference between actual and shadow profit, this indicates that an alternative solution exists giving the same profits. For example, some dresses could be ordered from Manufacturer *A* in Sizes II and III and from Manufacturer *B* in Size I.

4.0. CONCLUSION

As in the summary.

5.0. SUMMARY

1. The transportation problem is a linear programming problem that determination of the minimum cost plan for transporting goods and services from multiple sources to multiple destinations.
2. Three methods have been used to find the initial feasible solution namely (i) the north west corner method (ii) The least cost methods (iii) The Vogel's approximation method.
3. The North West corner method is the easiest method and the least cost method is the improvement of it while the Vogel's approximation method is the best.

4. The second phase produces optimum solution to the transportation problem.
5. It is desired that the number of cells having items allocated to them in the initial feasible solution be equal to $M + N - 1$ where M is the number of rows and N is the number of columns. If this criterion is not met then degeneracy occurs.
6. For the unbalance case we usually add a dummy variable to make up for the short fall in total supply or total demand. The cost in the dummy calls is given 0 values.
7. The objective of the transportation problems is to minimize total transportation cost.
8. There are linear programme packages that can be used in solving a transportation problem after a formulation of the mathematical model must have been done.
9. The Optimum solution can be found using the stepping stone method and the modified distribution (MODI) method.

6.0. TUTOR MARKED ASSIGNMENT

1. A firm of office equipment suppliers has three depots located in various towns. It receives orders for a total of 150 special filing cabinets available and the management wishes to minimize delivery costs by dispatching the filing cabinets from the appropriate depot for each customer. Details of the availabilities, requirements and transport costs per filing cabinet are given in the table below:

Depot	Customer				Total
	A	B	C	D	
X	#13	#11	#15	#20	20
Y	#17	#14	#12	#13	60
Z	#18	#18	#15	#12	70
Total	30	30	40	50	150

Determine the total number of filing cabinets that should be supplied from each depot and its distribution to minimize total transportation costs.

2. The weekly output figures for four factories I, II, III and IV are 220, 100, 65 and 40 units respectively. Five distributors A, B, C, D and E requires 190, 80, 55, 60 and 40 units respectively per week. Transport cost (in # per unit) from each factory to each distributor are given by the following table.

	A	B	C	D	E
<i>I</i>	1	3	2	4	5
<i>II</i>	4	1	2	3	5
<i>III</i>	5	4	1	3	2
<i>IV</i>	2	4	5	6	6

- a. Using the 'Least Cost First Method' to give the first solution, obtain the allocation which minimizes transport cost
- b. Comment on the uniqueness of the solution. What is the alternative solution?

7.0. REFERENCES/FURTHER READINGS

1. Operations Research. By Prem Kumar Gupta and D.S. Hira

2. Operations Research. (Problem Solvers) By Research and Education Association.
19. Statistics and Operations Research. By Debashis Dutta
20. Operations Research By). O.T. Arowolo and G.O. Lawal

UNIT 5 ASSIGNMENT MODEL

42.0. Introduction

43.0. Objective

44.0. Main Content

3.1. Assignment Table

3.2. Method of Solving Assignment Problems

3.3. Dummy Rows and Dummy Columns

45.0. Conclusion

46.0. Summary

47.0. Tutor Marked Assignment

48.0. Reference/ Further Readings

19.0 INTRODUCTION

An important variation of the transportation problem is the assignment problem. The assignment problem refers to a special class of linear programming problems that involve determining the most efficient assignment of people to projects, salesmen to territories, contracts to bidders, jobs to machines and so on.

The objective is most often to minimize total costs or total time of performing the task at hand. One important characteristic of assignment problem is that only one job (or work) is assigned to one machine or project. Because of its simple structure, the assignment problem can be solved most efficiently by its own unique method rather than by the previously described transportation methods.

20.0 OBJECTIVE

- * Understand the concept of assignment model
- * Solve assignment by enumeration method
- * Solve assignment by Hungarian method

21.0 MAIN TEXT

3.1 Assignment Table

The first step in solving an assignment problem is to develop an opportunity cost table or matrix associated with it. Generally, the rows will contain the objects or people we wish to assign and the columns comprise the tasks or things we want them assigned to. The numbers in the table are costs associated with each particular assignment.

3.2 Method of Solving Assignment Problems

There are basically two methods of solving the assignment problems:

i. Enumeration of Solution Method

The Enumeration method solve assignment problem by trying to see different permutation (arrangement) possible. Thereafter, we select the arrangement that gives the minimum cost. In case of a maximization problem, the arrangement that gives the maximum contribution will be selected. This method is better described by example. Below is an example to illustrate the Enumeration method.

EXAMPLE 1

The personnel director of Naira Finance corporation must assign three hired University graduates to three regional offices. The three new loan officers are equally well-qualified, so the decision will be based on the cost of allocating the graduates families. The cost data are presented in the accompanying table.

Officers	Locations (#)		
	<i>I</i>	<i>II</i>	<i>III</i>
<i>A</i>	11	14	6
<i>B</i>	8	10	11
<i>C</i>	9	12	7

SOLUTION

The objective of the problem is to assign the three officers to the various locations in a way that will result in the lowest total cost to the company.

Note

The assignment of people to location must be on a one-to-one basis, each location will be assigned exclusively to one officer only. Also, the number of rows must always equal the number of columns.

Project Assignment			Labour Costs		Total costs (#)
<i>I</i>	<i>II</i>	<i>III</i>			
<i>A</i>	<i>B</i>	<i>C</i>	11+10+7	=	28.00
<i>A</i>	<i>C</i>	<i>B</i>	11+12+11	=	34.00
<i>B</i>	<i>A</i>	<i>C</i>	8+14+7	=	29.00
<i>B</i>	<i>C</i>	<i>A</i>	8+12+6	=	26.00
<i>C</i>	<i>A</i>	<i>B</i>	9+14+11	=	34.00
<i>C</i>	<i>B</i>	<i>A</i>	9+10+6	=	25.00

Conclusion

The computation above shows that the least-cost solution would be to assign *C* to project *I*, *B* to project *II* and *A* to project *III* at a total cost of #25.00. Enumeration method works well for very small problems, but quickly becomes inefficient as the size of assignment problem become large.

ii. Hungarian Method or The Reduced Matrix Method

The Hungarian method of assignment provides us with an efficient means of finding the optimal solution without having to make comparison of every option. It operates on the principles of matrix reduction. This is done by just subtracting and adding appropriate numbers in the cost table/matrix.

The flow chart below gives an outline of the reduced matrix method to solve both maximization and minimization assignment problems.

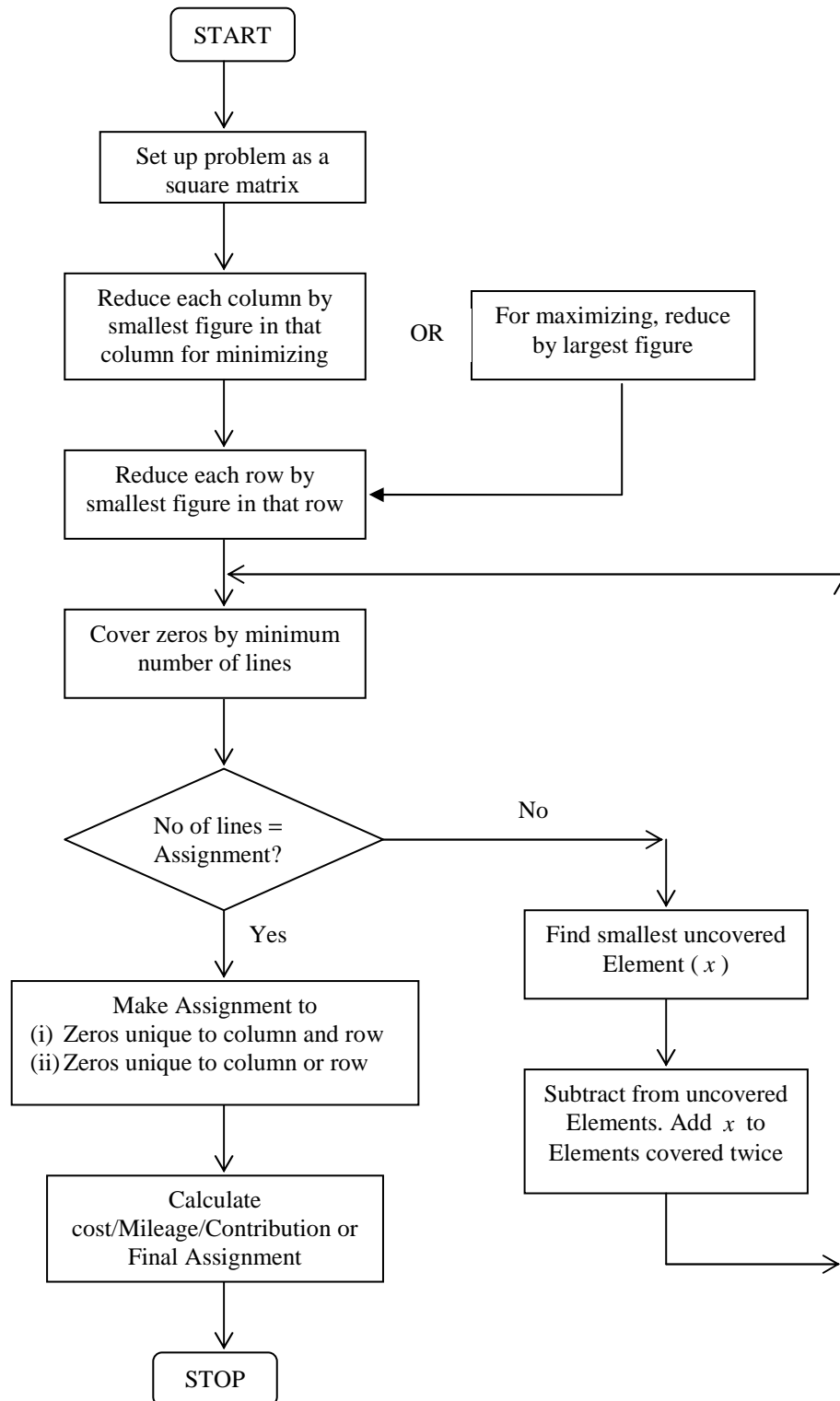

EXAMPLE 1

A company employs service engineers based at various locations throughout the country to service and repair their equipment installed in customers' premises. Four requests for service have been received and the company finds that four engineers are available. The distance each of the engineers is from the various customers is given in the following table and the company wishes to assign engineers to customers to minimize the total distance to be traveled.

Service Engineers	Customers			
	<i>W</i>	<i>X</i>	<i>Y</i>	<i>Z</i>
<i>A</i>	25	18	23	14
<i>B</i>	38	15	53	23
<i>C</i>	15	17	41	30
<i>D</i>	26	28	36	29

Table 1

SOLUTION**Step 1**

Reduce each column by the smallest figure in that column. The smallest figures are 15, 15, 23 and 14 and deducting these values from each element in the columns produces the following table.

	<i>W</i>	<i>X</i>	<i>Y</i>	<i>Z</i>
<i>A</i>	10	3	0	0
<i>B</i>	23	0	30	9
<i>C</i>	0	2	18	16
<i>D</i>	11	13	13	15

Table 2

Step 2

Reduce each row by the smallest figure in that row. The smallest figures are 0, 0, 0 and 11 and deducting these values gives the following table.

	W	X	Y	Z
A	10	3	0	0
B	23	0	30	9
C	0	2	18	16
D	0	2	2	4

Table 3

Note

Where the smallest value in a row is zero (i.e. as in rows A, B and C above) the row is, of course, unchanged.

Step 3

Cover all the zeros in Table 3 by the MINIMUM POSSIBLE number of lines. The lines may be horizontal or vertical.

	W	X	Y	Z	
A	10	3	0	0	Line 2
B	23	0	30	9	Line 3
C	0	2	18	16	
D	0	2	2	4	

Line 1 Table 4

Note

Line 3, covering row B, could equally well have been drawn covering column X.

Step 4

Compare the number of lines with the number of assignments to be made (in this example, there are 3 lines and 4 assignments). If the number of lines EQUALS the number of assignments to be made, go to Step 6. If the number of lines is LESS than the number of assignments to be made (i.e. as in this example which has three lines and four assignments) then:

- i. Find the smallest UNCOVERED element from Step 3, called x (in Table 4, this value is 2).
- ii. Subtract x from every element in the matrix.

- iii. Add back x to every element covered by a line. If an element is covered by two lines, for example, cell A: W in Table 4, x is added twice.

Note

The effect of these steps is that x is subtracted from all uncovered elements, elements covered by one line remain unchanged, and elements covered by two lines are increased by x .

Carrying out this procedure on Table 4 produces the following result:

In Table 4, smallest element is 2. The new table is:

	W	X	Y	Z
A	12	3	0	0
B	25	0	30	9
C	0	0	16	14
D	0	0	0	2

Table 5

Note

It will be seen that cells A:W and B:W have been increased by 2 ; cells A:X, A:Y, A:Z, B:X, B:Y, B:Z, C:W and D:W are unchanged, and all other cells have been reduced by 2 .

Step 5

Repeat Steps 3 and 4 until the number of lines covering the zeros equals the number of assignments to be made. In this example, covering the zeros in Table 5 by the minimum number of lines equals the number of assignments without any further repetition, thus:

	W	X	Y	Z	
A	12	3	0	0	Line 1
B	25	0	30	9	Line 2
C	0	0	16	14	Line 3
D	0	0	0	2	Line 4

Table 6

Step 6

When the number of lines EQUALS the number of assignments to be made, the actual assignments can be made using the following rules:

- i. Assign to any zero which is unique to BOTH a column and a row.
- ii. Assign to any zero which is unique to a column OR a row.
- iii. Ignoring assignments already made, repeat rule (ii) until all assignments are made.

Carrying out this procedure for our example, results in the following:

- i. (Zero unique to BOTH a column and a row). None in this example.
- ii. (Zero unique to column OR row). Assign B to X and A to Z.

The position is now as follows:

	<i>W</i>	<i>X</i>	<i>Y</i>	<i>Z</i>
<i>A</i>	row	Satisfied		Column satisfied
<i>B</i>	row	Satisfied		Column satisfied
<i>C</i>	0	Column satisfied	16	Column satisfied
<i>D</i>	0	Column satisfied	0	Column satisfied

Table 7

iii. Repeat rule (ii), results in assigning D to Y and C to W.

Notes

- i. Should the final assignment not be to a zero, then more lines than necessary were used in Step 3.
- ii. If a block of 4 or more zero's is left for the final assignment, then a choice of assignments exists with the same distance.

Step 7

Calculate the total distance of the final assignment.

<i>A</i> to <i>Z</i>	Distance	14
<i>B</i> to <i>X</i>	“	15
<i>C</i> to <i>W</i>	“	15
<i>D</i> to <i>Y</i>	“	<u>36</u>
		<u>80</u>

EXAMPLE 2

Example 1 will be used with the changed assumption that the figures relate to contribution and not distance and that it is required to maximize contribution.

SOLUTION

In each case, the Step number corresponds to the solution given for Example 1).

Original data.

	<i>W</i>	<i>X</i>	<i>Y</i>	<i>Z</i>
<i>A</i>	25	18	23	14
<i>B</i>	38	15	53	23
<i>C</i>	15	17	41	30
<i>D</i>	26	28	36	29

Contributions to
be gained

Table 8

Step 1

Reduce each column by LARGEST figure in that column and ignore the resulting minus signs.

	W	X	Y	Z
A	13	10	30	16
B	0	13	0	7
C	23	11	12	0
D	12	0	17	1

Table 9

Step 2

Reduce each row by SMALLEST figure in that row.

	W	X	Y	Z
A	3	0	20	6
B	0	13	0	7
C	23	11	12	0
D	12	0	17	1

Table 10

Step 3

Cover zeros by minimum possible number of lines.

	W	X	Y	Z
3	0	20	6	□ B □ 0 □
				B
C	23	11	12	0
D	12	0	17	1

Table 11

Step 4

If the number of lines equals the number of assignments to be made, go to Step 6. If less (as in example), carry out the 'uncovered element' procedure previously described. This results in the following table:

	<i>W</i>	<i>X</i>	<i>Y</i>	<i>Z</i>
<i>A</i>	0	0	17	6
<i>B</i>	0	16	0	10
<i>C</i>	20	11	9	0
<i>D</i>	9	0	14	1

Table 12

Step 5

Repeat Steps 3 and 4 until number of lines equals the number of assignments to be made. In this example, this occurs without further repetition, thus:

	<i>W</i>	<i>X</i>	<i>Y</i>	<i>Z</i>
<i>A</i>	0	0	17	6
<i>B</i>	0	16	0	10
<i>C</i>	20	11	9	0
<i>D</i>	9	0	14	1

Table 13

Step 6

Make assignments in accordance with the rules previously described which result in the following assignments:

- C* to *Z*
- D* to *X*
- A* to *W*
- B* to *Y*

Step 7

Calculate contribution to be gained from the assignments.

<i>C</i> to <i>Z</i>	30
<i>D</i> to <i>X</i>	28
<i>A</i> to <i>W</i>	25
<i>B</i> to <i>Y</i>	<u>53</u>
	<u><u>#136</u></u>

Notes

- i. It will be apparent that maximizing assignment problems can be solved in virtually the same manner as minimizing problems.
- ii. The solution methods given are suitable for any size of matrix. If a problem is as small as the illustration used in this chapter, it can probably be solved merely by inspection.

3.3 Dummy Rows and Dummy Columns

The solution procedure to assignment problems requires that the number of rows in the table equal the number of columns.

However, when the number of people or objects to be assigned does not equal the number of tasks or clients or machine listed in the columns, we have more rows and columns. We simply add a dummy column. If the number of tasks that need to be done exceeds the number of people available, we add a dummy row.

This creates matrix of equal dimensions and allows us to solve the problem as before. Since the dummy tasks or person is really non-existent, it is reasonable to enter zeros in its row or column.

Person	Projects			
	<i>I</i>	<i>II</i>	<i>III</i>	Dummy (#)
<i>A</i>	11	14	6	0
<i>B</i>	8	10	11	0
<i>C</i>	9	12	7	0
<i>D</i>	10	13	8	0

4.0. CONCLUSION

As in the summary

5.0. SUMMARY

1. Assignment problems, like the transportation problems are allocation problem as well as linear programming problems.
2. Assignment problem is a type of transportation problem.

3. Assignment problem can be used to minimize cost when executing N jobs from N sources, assigned to N individual at N locations.
4. We can use the linear programming models the complete enumeration method, the Hungarian method as well as the zero-one integer programming method to solve assignment problems.
5. If we have unequal rows or column we introduce dummy row or column to balance up the problem.

6.0. TUTOR MARKED ASSIGNMENT

1. “The assignment problem is a type of allocation problem”.
Required:
 - a. What do you understand by an assignment problem?
 - b. Explain one technique for solving such problems, illustrating your answer by means of a simple example.
2. Three jobs are to be assigned to three machines; each job can be assigned to one and only one machine. The cost in # of job on each machine is given in the following table:

Machine	Jobs		
	<i>I</i>	<i>II</i>	<i>III</i>
<i>A</i>	20	26	30
<i>B</i>	10	15	19
<i>C</i>	17	14	12

You are required to:

- a) Determine the job assignments which will minimize cost.
- b) Determine the minimum cost.

7.0. REFERENCES/FURTHER READINGS

1. Operations Research. By Prem Kumar Gupta and D.S. Hira
2. Operations Research. (Problem Solvers) By Research and Education Association.
21. Statistics and Operations Research. By Debashis Dutta
22. Operations Research By). O.T. Arowolo and G.O. Lawal

MODULE 3

UNIT 1 INVENTORY MODEL

CONTENTS

8.0	Introduction
9.0	Objective
10.0	Main Content
10.1	Types of Inventory
10.2	Reason for Holding Stock
10.3	Definition of Terms
10.4	Inventory Cost
10.5	EOQ Model
10.6	Inventory Control Systems.
11.0	Conclusion
12.0	Summary
13.0	Tutor Marked Assignment
14.0	References/Further

1.0 INTRODUCTION

Inventory is any stored resources that are used to satisfy present or future needs. It is an important part of financial control which is often neglected.

For example, a bank has a method of controlling its inventory of cash. A hospital has a method it uses to control the blood supplies and other important items.

Studying how organization controls their inventory is equivalent to studying how they achieve their objectives by supplying goods and services. Inventory is the common thread that ties all the functional parts of the organization together.

The overall objective of inventory function is to maintain stock levels so that the overall cost is at minimum. This is done by establishing two factors, when to order and how many to order. These factors shall be discussed later in this chapter.

2.0 OBJECTIVES

- Explain the concept of inventory
- Identify different types of inventory
- State the main reason for holding stock
- Define some important terminologies
- Identify the different EOQ model
- Determine the EOQ graphically and by use of model
- Differentiate the types of inventory control systems

3.0 MAIN CONTENT

3.1 Types of Inventory

Inventory can be conveniently be classified into the following:

- a) **Raw materials:** The materials, fuel, components, etc use in the manufacture of products.
- b) **Work-in-Progress:** Partly finished goods and materials, sub-assemblies, goods held between manufacturing stages etc.
- c) **Finished goods:** Completed products ready for distribution or sale.

The particular items included in each classification depend on the particular firm. What would be classified as a finished product for one company might be classified as raw materials for another. For example, steel bars would be classified as a finished product for a steel mill and as a raw material for a nut and bolt manufacturer.

3.2 Reason for Holding Stocks

The main reasons for holding stocks can be summarized as follows:

- a) To ensure that sufficient goods are available to meet anticipated demand.
- b) To absorb variation in demand and production.
- c) To provide a buffer between production processes. This is applicable to work-in-progress stocks which effectively decouple operations.
- d) To take advantage of bulk purchasing discount.
- e) To meet possible shortages in the future.
- f) As a necessary part of the production process e.g. maturing of whiskey.
- g) As deliberate investment policy, particularly in times of inflation or possible shortage.

Other Reasons of Holding Stocks

The reasons given above are the logical ones based on deliberate decision. However stocks accumulate for other, less praiseworthy reasons, they include the following:

- a) Obsolete items are retained in stock.
- b) Poor or non-existent inventory control resulting in over-large orders, replenishing orders being out of phase with production, etc.
- c) Inadequate or non-existent stock record.
- d) Poor liaison between the production control purchasing and marketing departments.
- e) Sub-optimal decision making e.g. the production department might increase W-I-P stocks unduly so as to ensure long production runs.

3.3 Definition of Terms

- a) Lead or Procurement time: The period of time, expressed in days, weeks, months, etc between ordering (either external or internal) and replenishment i.e. when the goods are available for use .
- b) Demand: The amount required by production, sales, etc usually expressed as rate of demand per week, month, year, etc.

Estimate of demand during the lead time are critical factors in inventory control systems.

- c) **Physical stock:** The number of items physically in stock at a given time.
- d) **Free stock:** Physical stock plus outstanding replenishment orders minus unfulfilled requirement.
- e) **Buffer stock or Minimum stock or Safety stock:** A stock allowance to cover errors in forecasting the lead time or the demand during the lead time.
- f) **Maximum stock:** A stock level selected as the maximum desirable which is used as an indicator to show when stock have risen too high.
- g) **Re-order level:** A level of stock at which a further replenishment order should be placed. The re-order level is dependent upon the lead time and the demand during the lead time.
- h) **Re-order Quantity:** The quantity of the replenishment order. In some types of inventory control systems this is the Economic Ordering Quantity (EOQ), but in some other systems a different value is used.
- i) **Inventory cycle:** The part of inventory graph which regularly repeats itself in a cycle form. This cycle will always include:
 - a. An ordering component (i.e. replenishment).
 - b. A demand component.
- j) **Length of cycle:** Is the length of time over which an inventory cycle extends.
- k) **Economic Order Quantity (EOQ) or Economic Batch Quantity (EBQ):** This is a calculated ordering quantity which minimizes the balance of cost between inventory holding costs and re-order costs. The rationale of (EOQ) is dealt with later in this chapter.

3.4 Inventory Costs

The purpose of all inventory models and techniques is to determine rationally how much to order and when to order. The major objective is to minimize total inventory costs, viz:

- a) Carrying (Holding) cost.
- b) Ordering cost.
- c) Stock-out (Shortage) cost.

d) Stock cost.

Whether as a result of deliberate policy or not, stock represents an investment by the organization. As with any other investment, the costs of holding stock must be related to the benefits to be gained. To do this effectively, the costs must be identified and this can be done in three categories: costs of holding stocks, costs of obtaining stock and stock-out costs.

○ Carrying (Holding) cost

This is the cost of holding an inventory item over a period of time. This includes:

- Cost of capital invested in the stock.
- Shortage charges (rent, lighting, refrigeration, etc).
- Stores staffing, equipment maintenance and running cost.
- Taxes.
- Insurance.
- Deterioration and obsolescence.
- Insurance, security.
- Audit, stock taking or perpetual inventory costs.
- Salaries and wages for warehouse employees.
- Supplies such as forms, paper, etc for the warehouse.

○ Ordering cost

This is the cost of placing an order. They include:

- Developing and sending purchase order.
- Processing and inspecting incoming inventory.
- Bill paying.
- Transport cost.
- Set up cost with each production run where goods are manufactured internally.
- Salaries and wages for purchasing department employees.

- Stock-out (Shortages) cost
These are costs associated with running out of costs. They include:
 - Loss of future sales because customer go elsewhere.
 - Loss of customer goodwill.
 - Cost of production stoppage caused due to stock-out of raw material or W-I-P (Work-in-Progress).
 - Labour frustration over stoppages.
 - Extra costs associated with urgent, often snap quantity replenishment purchases.
 - Penalty payment.

3.5 EOQ Models

The models that is commonly use is the Economic order quantity (EOQ). These models minimize the balance of cost between inventory holding costs and re-order costs. The EOQ is the order quantity which minimizes the total costs involved, which include holding costs and ordering costs. The EOQ calculation is based on constant ordering and holding cost, constant demand and instantaneous replenishment.

However, other variant of EOQ model exist. These include:

- i. EOQ model with gradual replenishment.
- ii. EOQ model with stock-out.
- iii. EOQ model with discount.

Basic Assumptions of EOQ Model

To be able to calculate a basic EOQ, certain assumptions are necessary:

- i. Rate of demand is known and constant.
- ii. Holding cost is known and constant.
- iii. Ordering cost is known and constant.
- iv. The price per unit is known and constant.
- v. Replenishment is made instantaneously i.e. the whole batch is delivered at once.
- vi. No stock-outs are allowed.
- vii. Quantity discounts are not possible.

3.6 Calculations and Formula

1. Ordering cost per annum = No of orders per annum × Order cost per order.

$$\text{No of orders} = \frac{\text{Annual demand}}{\text{No of units per order}} = \frac{\text{Annual demand}}{\text{Order quantity}}$$

$$= \frac{D}{Q}$$

$$\therefore \text{Ordering cost per annum} = D/Q \times C_o = DC_o/Q.$$

2. Annual holding cost = Average inventory level \times Holding cost per unit per annum.

$$\text{Average inventory level} = \frac{\text{Order quantity}}{2} = Q/2.$$

$$\text{Annual holding cost} = Q/2 \times C_h = QC_h/2.$$

3. Total cost per annum (TC) = Ordering cost per annum + Holding cost per annum.

$$TC = DC_o/Q + QC_h/2.$$

4. For optimal order quantity (EOQ),

$$\text{ordering cost} = \text{Carrying cost i.e. } \frac{DC_o}{Q} = \frac{QC_h}{2}.$$

$$\Rightarrow Q = \sqrt{\frac{2DC_o}{C_h}}$$

$$\text{i.e. } EOQ = \sqrt{\frac{2DC_o}{C_h}}.$$

5. Length of cycle (days) = $\frac{\text{Number of days per year}}{\text{Number of orders per year}}$

Note

- i. Let I be annual inventory holding charge of cost (i.e. rate of interest), then $C_h = IP$, where P = the unit cost of inventory items.

$$EOQ = \sqrt{\frac{2DC_o}{IP}}.$$

- ii. TC = Total cost
- Q = Order quantity
- D = Demand per annum
- C_o = Ordering cost per order.
- C_h = Carrying cost per item per annum.

Obtaining EOQ Formula from Calculus

$$\text{Total cost (TC)} = \frac{QC_h}{2} + \frac{DC_o}{Q}$$

$$\frac{d(TC)}{dQ} = \frac{C_h}{2} - \frac{DC_o}{Q^2}$$

$$\text{For optimal (i.e. at minimum cost)} \quad \frac{d(TC)}{dQ} = 0 \text{ i.e. } \frac{C_h}{2} - \frac{DC_o}{Q^2} = 0.$$

Making Q the subject of the formula:

$$\Rightarrow Q = \sqrt{\frac{2DC_o}{C_h}}$$

$$EOQ = \sqrt{\frac{2DC_o}{C_h}}$$

The EOQ Formula

It is possible and more usual to calculate the EOQ using a formula. The formula method gives an exact answer, but do not be misled into placing undue reliance upon the precise figure. The calculation is based on estimates of costs, demands, etc which are of course, subject to error. The EOQ as stated earlier is given below:

The basic EOQ formula is $EOQ = \sqrt{\frac{2DC_o}{C_h}}$; where

C_o = Ordering/purchase cost per order.

C_h = Holding/carrying cost per item per annum.

D = Demand per annum.

EXAMPLE 1

Given that: $C_o = \text{\#}150$, $D = 50,000$ kg, $C_h = \text{\#}1.50$.

$$\therefore EOQ = \sqrt{\frac{2 \times 150 \times 50000}{1.5}} = \sqrt{10,000,000} \approx 3162 \text{ kg.}$$

Note

- i. The closest value obtainable from the graph was approximately of Example 3 (see graph), which is very close to the exact figure.
- ii. Always take care that demand and carrying costs are expressed for the same time period. A year is the usual period used.
- iii. In some problems, the carrying cost is expressed as a percentage of the value whereas in others, it is expressed directly as a cost per items.

EXAMPLE 2

The managing director of a manufacturing company suspects that, is not importing a particular spare part in the most economic way.

A financial analysis shows that:

It cost #850 to make an order.

Each item cost #83.60.

The annual holding costs are 15 per cent of the price paid.

The current annual consumption is #650,000.00 .

You are required to determine:

- a) The best order size.
- b) The number of days this supply would last.
- c) The number of orders per year? (Assume 1 year = 260 working days).

SOLUTION

Ordering cost per order, $C_o = \text{R}850.00$.

Unit Annual Holding cost, $C_h = 0.15 \times \text{R}83.60 = \text{R}12.54$.

Annual Demand, $D = \frac{650,000}{83.60} \approx 7775$ units (to the nearest whole number).

$$a) \quad EOQ(Q) = \sqrt{\frac{2C_o D}{C_h}} = \sqrt{\frac{2 \times 850 \times 7775}{12.54}}$$

\therefore Best order size is 1027 units.

b) Number of days this supply will last is:

$$\frac{Q}{D} \times \text{Number of days in a year} = \frac{1027}{7775} \times 260 \text{ days} = 34.34 \text{ days.}$$

$$c) \quad \text{Number of orders per year} = \frac{D}{Q} = \frac{7775}{1027} = 7.57.$$

Graphical Solution to EOQ

Apart from the formulae, EOQ could be approximately found from the inventory graph. The purpose of graph is:

- i. To give knowledge of the amount of stock held at any time by plotting the relationship between the quantity of stock (Q) held and time (t), and
- ii. To be able to estimate the minimum cost and the respective quantity to order.

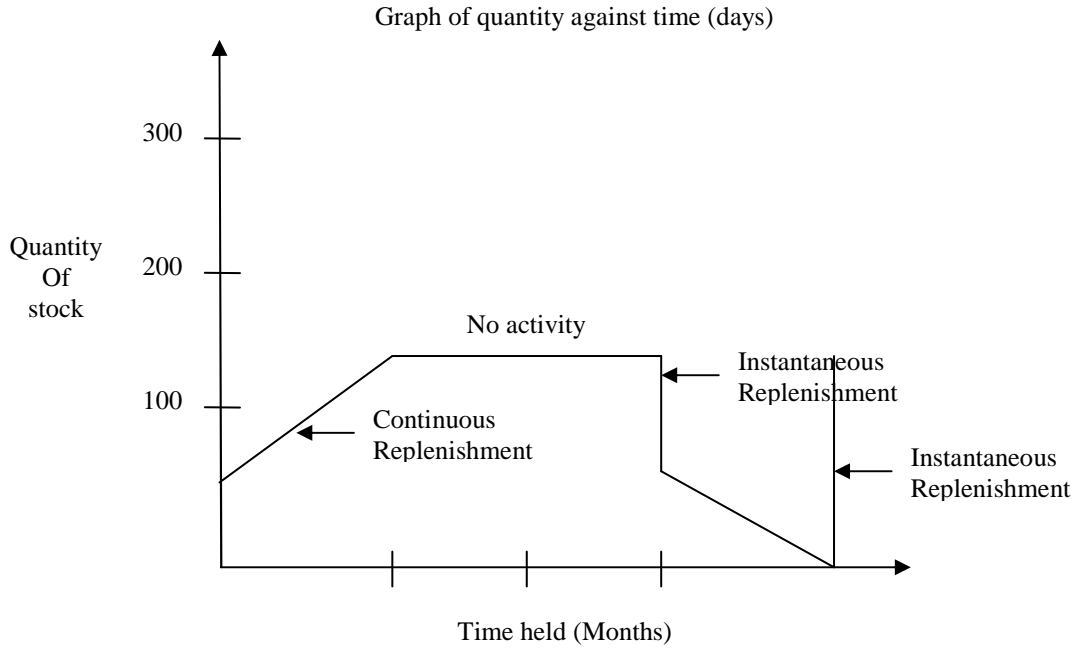

Fig. 2

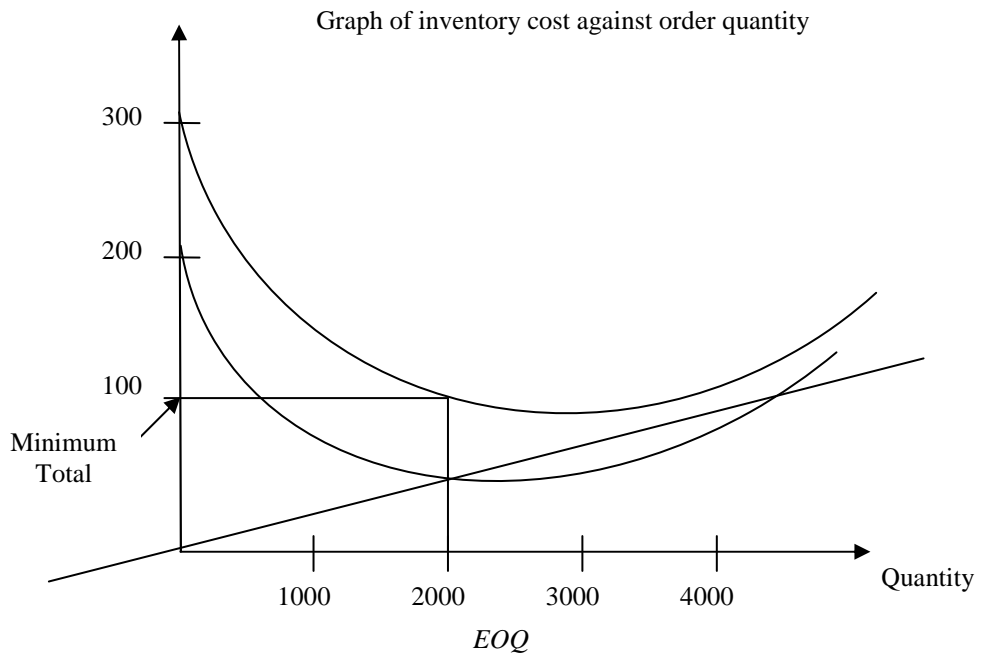

Fig. 3

EXAMPLE 3

A particular item of stock has an initial inventory of 400. A particular product line requires the items to be drawn (continuously) from stores at a steady rate of 100 per day. As soon as stock-out is reached, a batch of 400 items is moved in overnight from another source to replenish the inventory. Sketch the graph for 16 days.

SOLUTION

Fig. 4

$$\text{Inventory cycle} = \frac{400}{100} = 4 \text{ days.}$$

$$\text{Average inventory level} = \frac{\text{Total area under graph}}{\text{Total time taken}}$$

$$\text{Total area} = 4 \left(\frac{1}{2} \times 4 \times 400 \right) = 3200$$

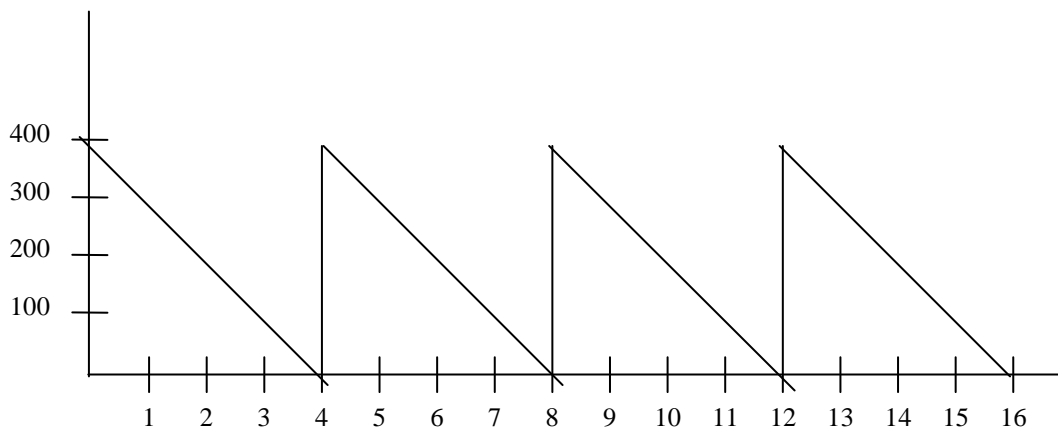
$$\therefore \text{Average inventory level} = \frac{3200}{16} = 200 \text{ items.}$$

EXAMPLE 4

A company uses 50,000 of a particular raw material per annum which are #10 each to purchase. The ordering costs are #150 per order and carrying costs are 15% per annum (i.e. it cost 15% of #10 = #1.50 per annum to carry the material in stock).

Required; develop a graphical solution to the EOQ problem.

SOLUTION

Total costs per annum = Ordering cost + Holding costs.

$$\text{Ordering cost per annum} = \frac{\text{Annual demand}}{\text{Ordering quantity}} \times \text{cost of orders}$$

Holding (carrying) cost = Average stock level \times Cost of holding.

$$= \frac{\text{Order quantity}}{2} \times (15\% \text{ of } \#10)$$

$$= \frac{\text{Order quantity}}{2} \times \#1.50.$$

Order quantity	Average number of orders p.a $\left[\frac{50000}{\text{OrderQty}} \right]$	Annual ordering cost (C_o) (#) [Average number of stock \times #150]	Average stock $\left[\frac{\text{OrderQty}}{2} \right]$	Holding cost p.a (C_h) [Average stock \times #1.50]	Total cost [$C_o + C_h$]
1000	50	7500	500	750	8250
2000	25	3750	1000	1500	5250
3000	$16\frac{2}{3}$	2500	1500	2250	4750
4000	$12\frac{1}{2}$	1875	2000	3000	4875
5000	10	1500	2500	3750	5250
6000	$8\frac{1}{3}$	1250	3000	4500	5750

The costs in the table above can be plotted in a graph and the approximate EOQ ascertained.

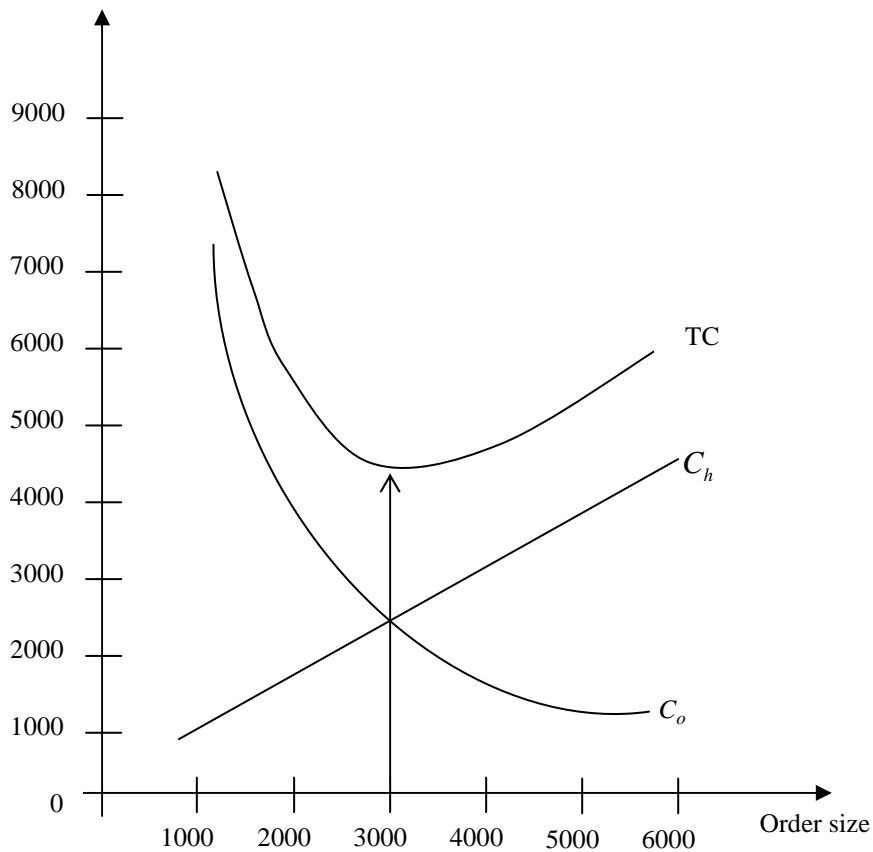

Fig. 5

From the graph, it will be seen that EOQ is approximately 3,200 kg, which mean that an average slightly under 16 orders will have to be placed a year.

Note

- i. From a graph closer, accuracy is not possible and is unnecessary anyway.
- ii. It will be seen from the graph that, the bottom of the total cost curve is relatively flat, indicating that the exact value of EOQ situations.

EOQ Model with Gradual Replenishment

This is also known as the production run model. It is an inventory model in which stock are received from a production line in the organization (that is, the manufacturer becomes the stock holder). It has the same characteristic as the basic model with reference to constant Demand (D), Cost of ordering (C_o) and Cost of holding (C_h) except that:

- i. Production run is started at zero inventory level and stops at q inventory level (i.e. q items are produced and supplied) with a run time, t .
- ii. The quantity order per cycle is known as run size and items are supplied at a set R per annum. Effective replenishment rate $R - D$ items.

Inventory Graph with Gradual Replenishment

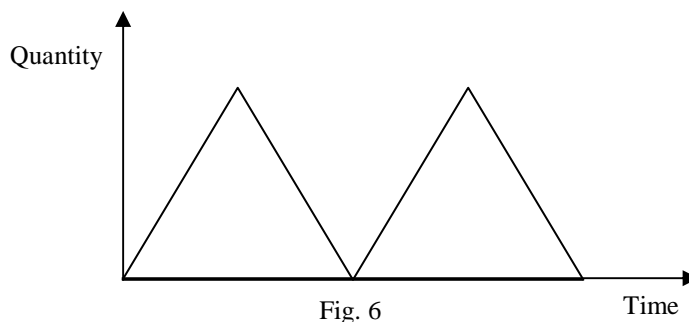

Formula for EOQ with Gradual Replenishment

It is associated with the following:

- i. *Set-up cost* (C_s): Is the cost of the setting up the production facility to manufacture the product;
 - Salaries and wages of employees for setting up equipment.
 - Engineering and design cost of making set-up.
 - Paper work, supplies, utilities, etc.
- ii. Holding cost (C_h).
- iii. Demand rate (D).

o Derivation

i. Annual cost of holding = Average inventory level $\times C_h$.

ii. Average inventory level = $\frac{\text{Maximum inventory level}}{2}$

iii. Maximum inventory level = Effective replenishment rate \times Run time

= (Quantity produced during production) – (Quantity used during production run).

Quantity produced (Q) = Rt

$\Rightarrow t = Q/R$

t = Run time, R = Daily production rate.

\therefore Maximum inventory level = $Rt - Dt$
 $= Q - DQ/R$
 $= Q(1 - D/R)$.

Average inventory level = $Q(1 - D/R)/2$.

Cost of holding = Average inventory level $\times C_h$.
 $= Q(1 - D/R)/2 \times C_h$.

iv. Annual cost of set-up = (Quantity produced during production) \times (Quantity used during production run).
 $= D/Q \times C_s$.

Optimal set-up cost is obtained when the holding cost = cost of set-up.

$Q(1 - D/R)C_h/2 = DC_s/Q$

Simplify, $Q = \sqrt{\frac{2DC_s}{C_h(1 - D/R)}}$.

v. EOQ (With gradual replenishment) is $\sqrt{\frac{2DC_s}{C_h(1 - D/R)}}$.

Note

In the case where inventory is ordered instead of produced, we replace C_s (set-up cost) with C_o (ordering cost) in the EOQ formulae with gradual replenishment i.e.

$EOQ = \sqrt{\frac{2DC_o}{C_h(1 - D/R)}}$.

vi. Length of cycle = $\frac{\text{Number of days per year}}{\text{Number of runs per year}}$

vii. Number of runs per year = $\frac{\text{Yearly demand}}{\text{EOQ}}$

viii. Average inventory level = $\frac{\text{Maximum inventory level}}{2}$

Obtaining EOQ (with Gradual Replenishment) from Calculus

Total cost (T) = $DC_s/Q + QC_h(1 - D/R)/2$.

For optimal (minimum) cost, $dT/dQ = 0$.

$\therefore dT/dQ = -DC_s/Q^2 + C_h(1 - D/R)/2 = 0$

$$\Rightarrow Q = \sqrt{\frac{2DC_s}{C_h(1 - D/R)}}$$

EXAMPLE 5

Assume that the firm described in Example 8 has decided to make the raw materials in its own factory. The necessary machinery has been purchased which has a capacity of 180,000kg per annum. All other data are assumed to be the same.

SOLUTION

$$\begin{aligned} \text{EOQ (With gradual replenishment)} &= \sqrt{\frac{2DC_o}{C_h(1 - D/R)}} \\ &= \sqrt{\frac{2 \times 120 \times 30,000}{9.6 \left(1 - \frac{30,000}{180,000}\right)}} \\ &= 948.68 \approx 949. \end{aligned}$$

Note

- i. The value obtained above is larger than the basic EOQ because the usage during the replenishment period has the effect of lowering the average stock-holding cost.
- ii. The ordering cost for internal ordering usually includes set-up and tooling cost as well as paper work and administration cost.

EOQ with Stock-out

This model is called the back order or planned shortages inventory model. A back order is the situation in which a customer places an order, finds that the supplier is out of stock and waits for the next shipments (back order) to arrive.

Assumptions

- i. Customers' sale will not be lost due to stock-out.
- ii. Back orders will be satisfied before any new demand for the product.

The following variables are used:

Q = Ordered quantity per order.

D = Annual demand in units.

C_h = Holding cost per unit per year.

C_o = Ordering cost per order.

C_s = Stock-out cost per unit per year.

$$\text{EOQ (with stock-outs)} = \sqrt{\frac{2DC_o(C_s + C_h)}{C_h C_s}}$$

Total cost = Ordering cost + Holding cost + Stock-out cost.

Annual ordering cost = $C_o D / Q$.

$$\text{Quantity back order, } S = Q - \frac{QC_s}{C_h + C_s} = \frac{QC_h}{C_h + C_s}$$

Inventory Graph

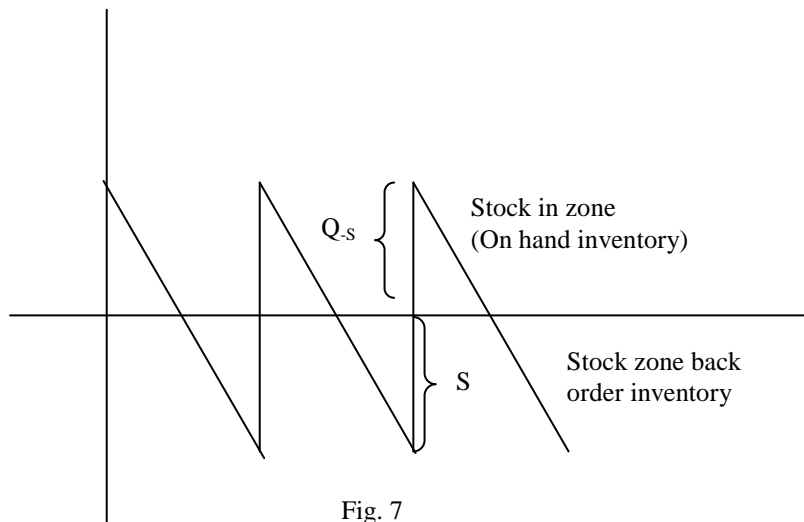

Fig. 7

EXAMPLE 6

Assume the same data as in Example 8 except that stock-outs are now permitted. When a stock-out occurs and an order is received for raw materials, the firm has agreed to retain the order and when replenishments are received to use express courier service for the delivery at a cost of 65kobo per kg . Other administrative costs associated with stock-outs are estimated at 15kobo per unit. What is the EOQ?

SOLUTION

$C_o = \text{#}120, D = 30,000, C_h = \text{#}9.6, C_s = 65k + 15k = 80k = \text{#}0.8.$

$$\begin{aligned} \text{Thus, } EOQ &= \sqrt{\frac{2C_o D(C_h + C_s)}{C_h + C_s}} \\ &= \sqrt{\frac{2 \times 120 \times 30000(9.6 + 0.8)}{9.6 + 0.8}} \approx 2683. \end{aligned}$$

EOQ with Discounts

A particular unrealistic assumption with the basic EOQ calculation is that the price per item remains constant. Usually, some form of discount can be obtained by ordering increased quantities. Such price discounts can be incorporated into the EOQ formula, but it becomes much more complicated. A simpler approach is to consider the costs associated with the normal EOQ and compare these costs with the costs at each succeeding discount points and so ascertain the best quantity to order.

Financial Implications of Discounts

Price discounts for quantity purchases have three financial effects, two of which are beneficial and one, adverse.

Adverse Effects

Increase costs arise from the extra stockholding costs caused by the average stock level being higher due to the larger order quantity.

EXAMPLE 7(EOQ with Discounts)

A company uses a special bracket in the manufacture of its products which it orders from outside suppliers. The appropriate data are:

Demand = 2000 per annum.

Ordering cost = #20 per order.

Carrying cost = 20% of item bracket.

The company is offered the following discounts on the basic price:

For order quantities:

400 – 799 Less 2%

800 – 1595 Less 4%

1600 and over Less 5%

It is required to establish the most economical quantity to order.

SOLUTION

This problem can be answered using the following procedure:

- i. Calculate the EOQ using the basic price.
- ii. Compare the savings from the lower price and ordering costs and the extra stockholding costs at each discount point (i.e. 400, 800 and 1600) with the costs associated with the basic EOQ, thus;

$$\text{Basic } EOQ = \sqrt{\frac{2 \times 2000 \times 20}{10 \times 0.2}} = 200 \text{ brackets.}$$

Based on this EOQ, the various costs and saving comparisons are given in the following table.

Cost/Savings Comparisons EOQ to Discount Points

Line No.	Order Quantity	200(<i>EOQ</i>)	400	800	1600
1.	Discount		2%	4%	5%
2.	Average No. of Orders P.A.	10	5	$2\frac{1}{2}$	$1\frac{1}{4}$
3.	Average No. of Orders saved P.A.		5	$7\frac{1}{2}$	$8\frac{3}{4}$
4.	Ordering cost savings P.A.		$(50 \times 2) = 100$	$(7\frac{1}{2} \times 20) = 150$	$(8\frac{3}{4} \times 20) = 175$
5.	Price saving per item per annum		20 p $(2000 \times 20 \text{ p}) = 400$	40 p $(2000 \times 40 \text{ p}) = 800$	50 p $(2000 \times 50 \text{ p}) = 1000$
6.	Total gains		500	950	1175
7.	Stockholding cost P.A.	$(100 \times 10 \times 2) = 200$	$(200 \times 9.8 \times 2) = 392$	$(400 \times 9.6 \times 2) = 768$	$(800 \times 9.5 \times 2) = 1520$
8.	Additional costs incurred by increased order quantity		$(392 - 200) = 192$	$(768 - 200) = 568$	$(1520 - 200) = 1320$
9.	Net Gain		308	382	145

From the above table, it will be seen that the most economical order quantity is 800 brackets, thereby gaining the 4% discount.

Precaution

- a) Line 2 is $\frac{\text{Demand of 2000}}{\text{Order quantity}}$
- b) Line 7 is the cost carrying the average stock i.e.
 $\frac{\text{Order quantity}}{2} \times \text{cost per item} \times \text{carrying cost percentage}$
- c) Line 9 is 6 minus Line 8.

3.6 **Inventory Control Systems**

There are two basic inventory control systems; the re-order level or two-bin system and the periodic review system.

- Re-order level system

This system sets a fixed quantity of stock for each stock item (EOQ), which is ordered every time the level of stocks meet or falls below the calculated re-order level. There are three levels of stock set by the system. They are:

- i. Re-order level;
- ii. Minimum level; and
- iii. Maximum level.

- Re-order level

This is an action level of stock which causes replenishment order to be placed.

$$\text{ROL} = \text{Maximum usage} \times \text{Maximum lead.}$$

- Minimum level

This is a warning level set; such that only in extreme cases (i.e. above average demand or replenishment) should it be breached.

$$L_{\min} = \text{Re-order level} - \text{Average usage for average lead time i.e. } L_{\min} = \text{ROL} - (\text{Normal usage} \times \text{Average lead time})$$

- Maximum level

This is a warning level set; such that only in extreme cases (i.e. low level of demand) should it be breached.

$$L_{\max} = \text{ROL} + \text{EOQ} - (\text{Min. usage} \times \text{Minimum lead time})$$

$$L_{\max} = \text{ROL} + \text{EOQ} - (\text{Minimum usage in lead time}).$$

EXAMPLE 8

The minimum, normal and maximum usage of an inventory are 300, 500 and 700 respectively. The lead time varying between 4 to 8 weeks both an average of 6 and the normal ordering quantity (EOQ) is 10,000 .

Find:

- Re-order level.
- Minimum level.
- Maximum level.

SOLUTION

$$\begin{aligned} \text{a) Re-order level (ROL)} &= \text{Maximum usage} \times \text{Maximum lead time.} \\ &= 700 \times 8 = 5,600 . \end{aligned}$$

$$\begin{aligned} \text{b) Minimum level} &= \text{ROL} - \text{Average usage for average lead time.} \\ &= 5,600 - (500 \times 6) \\ &= 5,600 - 3,000 \\ &= 2,600 . \end{aligned}$$

$$\begin{aligned} \text{c) Maximum level} &= \text{ROL} + \text{EOQ} - \text{Minimum usage in lead time.} \\ &= 5,600 + 10,000 - (300 \times 4) \\ &= 14,400 . \end{aligned}$$

❖ Advantages of Re-order level system

- Lower stocks on average.
- Items ordered are Economic quantities via the EOQ calculations.
- Somewhat more responsive to fluctuation in demand.

- iv. Automatic generation of a replenishment order at the appropriate time by comparison of stock level against re-order level.
- v. Appropriate for widely differing types of inventory within the same firm.

❖ Disadvantages of Re-order level system

- i. Many items may reach re-order level at the same time, thus overloading the re-ordering system.
- ii. Items come up for re-ordering in a random manner so that there is no set sequence.
- iii. In certain circumstances (e.g. variable demand, ordering costs, etc.), the EOQ calculation may not be accurate.

Periodic Review System

This system set a review period at the end of which stock level of each item is brought up to a pre-determined value. The effect of the system is to order variable quantities at fixed intervals as compared with the re-order level system where fixed quantities are ordered at variable intervals. The graph in figure 1 shows the periodic review system.

❖ Advantages of Periodic Review System

- i. It prevents stock items from being obsolete.
- ii. Larger quantity of discounts may be obtained when a range of stock items are order at the same time from a supplier.
- iii. Economies in placing orders may be gained when a range of stock items are ordered at the same time from a supplier.
- iv. Because orders will always be in the same sequence, there may be production economies due to more efficient production planning being possible and lower set up costs.

❖ Disadvantages of Periodic Review System

- i. In general, larger stocks are required as re-order quantities must take account of the period between review as well as lead times.
- ii. Re-order quantities are not at the optimum level of a currently calculated Economic order quantity (EOQ) .
- iii. Unless demands are reasonably consistent, it is difficult to set appropriate period for review.
- iv. Less responsive to changes in consumption. If the rate of usage change shortly after review, a stock-out may well occur before the next review.

The graph below shows the periodic review system of a product stored in inventory over a period of 16 weeks

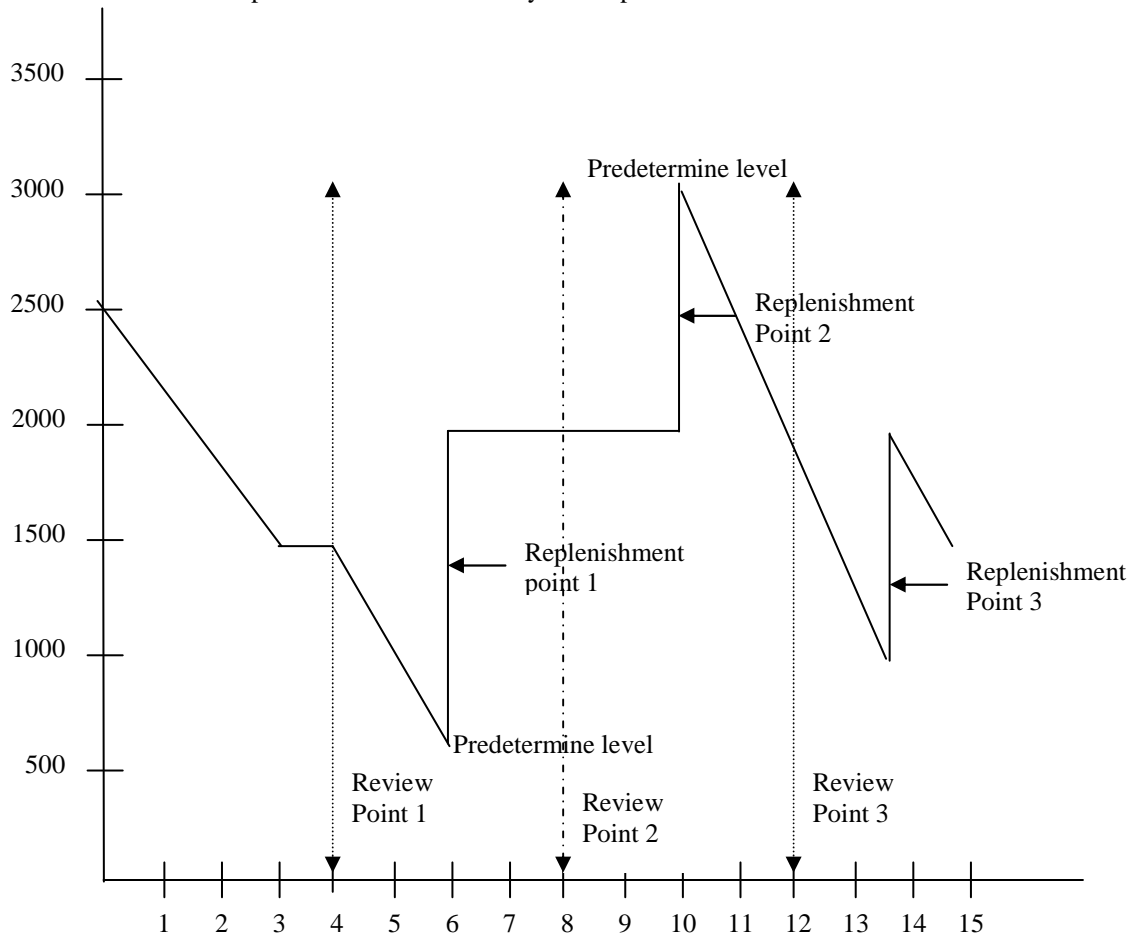

Fig. 1

Notes on the Graph

1. Review period is 4 weeks interval (order placed at 4th, 8th and 12th weeks).
2. Lead time is 2 weeks (replenishment made at 6th, 10th and 14th weeks).
3. Amount of each order is always the difference between the current stock level and the pre-determined level.

Thus, for order 1 (week 4 stock level = 1,500). The replenishment made at 6, therefore; inventory level = 500 + 1,500 = 2000 and so on.

4.0 Conclusion

As in the summary

5.0 Summary

Inventory is stock stored for future use.

The main objectives of inventory is to ensure that customers are satisfied with respect to prompt and ready supply of good as well as minimizing cost of keeping inventory.

Two key questions in inventory control “when do we order?” and “What quantity should we order?”

Inventory control can be done using quantitative techniques or graphical method.

The Economic order quantity is a basic deterministic model that enables one to determine the optimal order quantity that will minimize the costs of managing the inventory system.

The quantity is given as $Q = \sqrt{2CD}$ where D = demand for item no inventory,

C = Ordering cost per unit order, H = Holding cost and these presentations are usually on annual basis.

$$\text{Optimum total inventory cost} = T = \frac{CD}{Q} + \frac{HQ}{2} = 2\sqrt{CHD}$$

The quantity discount model is such that provision is made for discount for large quantity and the total cost here is as sum of

ordinary cost, holding cost and purchase price i.e $T = CD/Q + HQ/2 + SD$ where $S =$ unit price or cost of purchase item.

The Economic Batch Quantity Model, also known as the Economic product cost size model is applicable where production is greater than demand and replenishment of goods take times.

Here $Q = \sqrt{\frac{2CD}{H(1 - D/R)}}$ Where D is the demand. Also total cost

$$\text{Price} = \frac{HQ(1 - D) + CD}{R} = \sqrt{\frac{2CDH(1 - D)}{R}}$$

6.0 Tutor Marked Assignment

1(a). What do you understand by Economic Order Quantity (EOQ)?

Derive the model for computing the EOQ.

- (b). Define the term inventory control.
 - (c). List out the factors usually taken into consideration when formulating an inventory model.
- 2 (a). List out the costs associated with inventory control.
- (b). Why is inventory management significant in the firm's activities?
 - (c). What is the overall importance of inventory to management?

3 The demand for brackets of a particular type is 3,000 boxes per year. Each order, regardless of the size of order, incurs a cost of #4. The cost of holding a box of brackets for a year is reckoned to be 60k. Determine the economic order quantity and the frequency of ordering.

7.0 References/Further Readings

1. Operations Research. By Prem Kumar Gupta and D.S. Hira

2. Operations Research. (Problem Solvers) By Research and Education Association.
23. Statistics and Operations Research. By Debashis Dutta
24. Operations Research By). O.T. Arowolo and G.O. Lawal

UNIT 2 NETWORK ANALYSIS

CONTENTS

- 1.0 Introduction**
- 2.0 Objectives**
- 3.0 Main Text**
 - 3.1 Historical Background**
 - 3.2 Methodology of CPA and PERT**
 - 3.3 Notation and Construction**
- 1.0 INTRODUCTION**

Network model is a powerful tool in the management of projects, particularly those consisting of large number of activities related in complex ways. Most realistic projects that organizations undertake are large and complex. Almost every industry worries about how to manage their large-scale and complicated projects effectively. Drawing a network model provides a visual display of these relationships concerned and a way of answering various questions about the project.

Programme Evaluation and Review Techniques (*PERT*) and the Critical Path Analysis (*CPA*) are two popular techniques that help manager plan, schedule, monitor and control large and complex projects.

Some common application of network analysis occurs in project scheduling for:

- i. Construction
- ii. Engineering
- iii. Manufacturing
- iv. The management of administrative systems.

Historical Background

A basic form of network model was being used in the mid 1950's in an attempt to reduce project times.

In 1958, the US Naval special project office set up a team to devise a technique to control the planning of complex projects. The outcome of the team's efforts was the development of the network known as *PERT* (Programme Evaluation and Review Technique).

PERT was used to plan and control the development of the Polaris missile and was credited with saving two years in the missile's development.

Since 1958, the technique has been developed and nowadays Network model is operated in various forms under a number of titles which include the following:

- i. Critical Path Method (*CPM*)
- ii. Programme Evaluation and Review Technique (*PERT*)
- iii. Critical Path Planning (*CPP*)
- iv. Critical Path Analysis (*CPA*)
- v. Critical Path Scheduling (*CPS*)
- vi. Minimal Spanning Tree
- vii. Shortest routes problem, etc.

In this text, we shall discuss the first two technique (i.e *CPA* and *PERT*).

Procedure of CPA and PERT

Using any of the above network techniques involves the following steps:

- i. Define the project and all its significant activities.
- ii. Develop the relationship among the activities by deciding which activities must proceed and follow others.

- iii. Draw the network connecting all of the activities.
- iv. Assign time and/or cost estimates of each activity.
- v. Compute the longest time path through the network (this is called the critical path).
- vi. Use the network to help plan, scheduled, monitor and control project.

o **Differences between CPA and PERT**

<i>CPA</i>	<i>PERT</i>
i. It is a deterministic approach	It is a probabilistic technique which allows us to find the probability that the entire project will finish at a given date.
ii. Uses two-time estimates – normal time and crash time.	Uses three-time estimate – optimistic time, most likely time and pessimistic time.

Notation and Construction

i. (a) Activity

This is a task or job that consumes time or resources e.g. ‘Verify debtors in a sales ledger’; ‘Dig foundation’; ‘Type report’, etc.

The symbol used is an arrow →

The head of the arrow indicates where the job ends and the tail where the job starts.

(b) Dummy Activity

This is an activity that does not require time or resources. It is used merely to show logical dependencies between activities so as not to violate the rules of drawing networks. The symbol used is an arrow with broken lines.

→

It should be noted that the method of network construction presented in this book is “activity on the arrow” (the alternative is referred to as “activity on the node”).

ii. Event/Node

It is a point in time that marks the start or end of an activity.

The symbol used is a circle with a number to locate its position.



iii. Network

This is a combination of activities, dummy activities and events in a logical sequence according to the rules of drawing networks. See below example of a network diagram.

Example of a Network Diagram

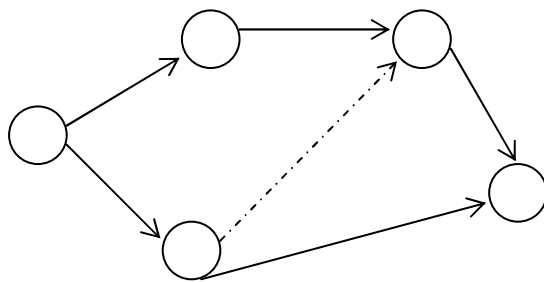

Rules for Drawing Network Diagrams

- i. A complete network should have only one point of entry (a start event) and only one point of exit (a finish event).
- ii. Every activity must begin with one tail event (predecessors) and end with one head event (successor).

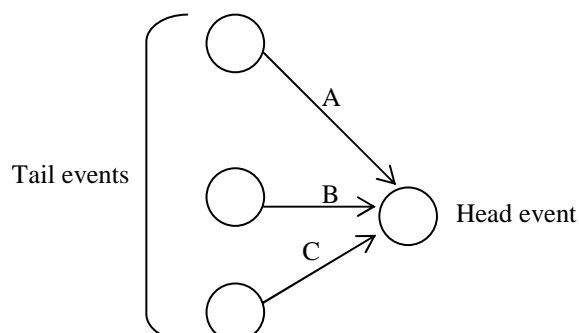
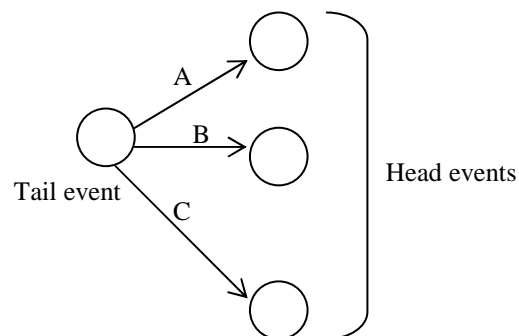

Note: An activity must not share the same head and tail event with other activity.

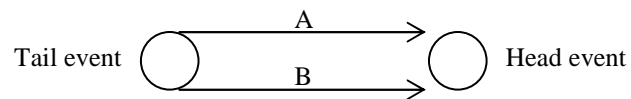

This is not allowed.

iii. No activity can start until its tail event is reached.

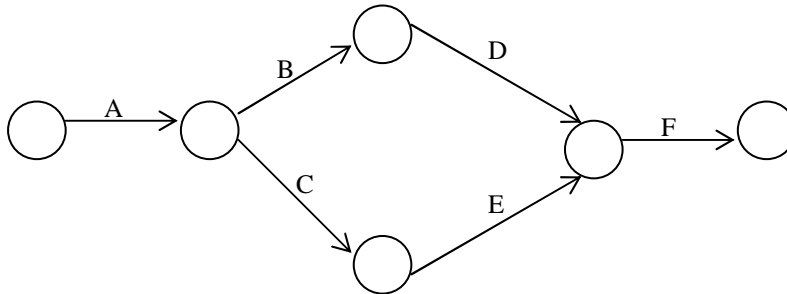

Event *F* cannot start until all activities (*D* and *E*) leading to it are completed.

iv. Loops are not allowed. Loops are activities leading to the same event.

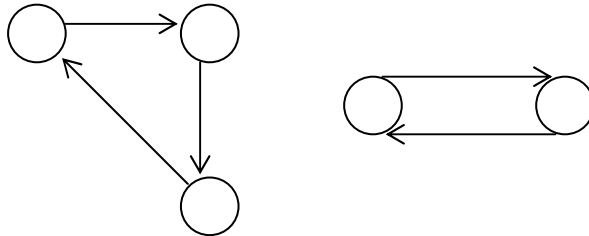

These are not allowed.

v. Dangling activities are not allowed; in other words, all activities must contribute to the Network diagram otherwise they are discarded as irrelevant.

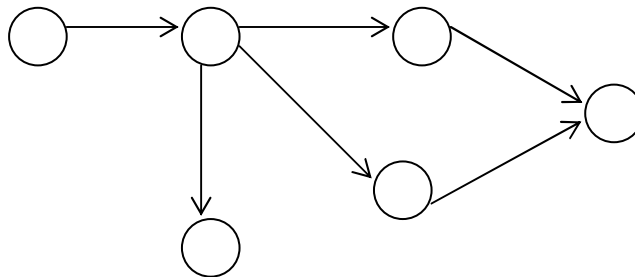

Dangling.

vi. Network proceeds from left to right.

Note

- a) Network diagram are not drawn to scale as arrows does not represent time elapse.
- b) Arrows need not be drawn in the horizontal plane.
- c) Events should be progressively numbered from left to right e.g. 0,1,2,... or 0,10,20,30,...etc.
- d) Activities can be identified by their:
 - i. Short description e.g. Type a report.
 - ii. Alphabetic or Numeric code e.g. A, B, C, ... or 1,2,3,...
 - iii. Tail and head events numbers e.g. 1-2, 2-3, 3-5, etc.

Use of Dummy Activities

Dummy activities are merely used to complete a network diagram, for a good logical relationship.

EXAMPLE 1

Assume that part of the network involves a car arriving at a service station during which two independent activities take place; 'filling with petrol' (A) and 'topping up with oil' (B). This could be shown thus:

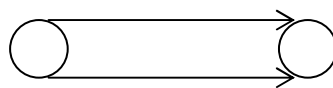

(Incorrect)

Note: This is wrong because it contravenes rule II. By the use of a dummy activity it could be shown thus:

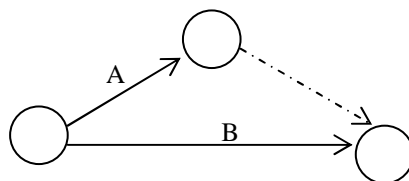

Or,

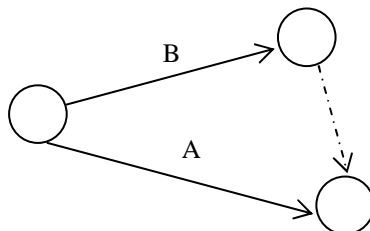

EXAMPLE 2

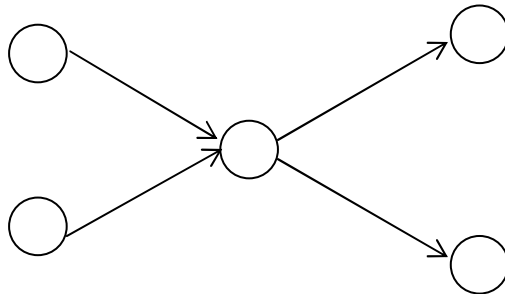

This illustration is wrong.

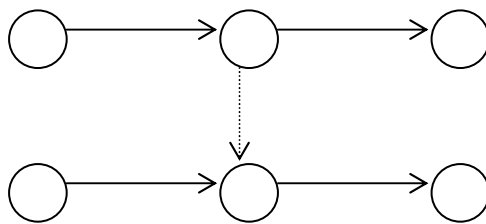

This illustration is correct.

Now, we can give illustration on how to draw Network diagram.

EXAMPLE 3

A project consists of the following activities as tabulated below:

Activity	Preceding Activity
<i>A</i>	-
<i>B</i>	-
<i>C</i>	-
<i>D</i>	<i>A</i>
<i>E</i>	<i>A</i>
<i>F</i>	<i>B</i>
<i>G</i>	<i>B</i>
<i>H</i>	<i>C, F</i>
<i>I</i>	<i>D, G, H</i>

Required

Construct the network of the above project using activity-on-arrow diagram.

SOLUTION

Stage 1

The first three activities *A*, *B* and *C* starts the event of the network diagram because nothing precedes them. Thus, we have:

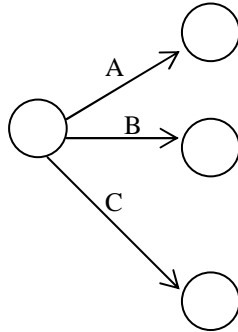

Note

The order of arrangement is not important. This may change in the course of during the complete diagram.

Stage 2

Case 1: Activities *D* and *E* preceded by activity *A*.

Or,

Case 2: Activities *F* and *G* are preceded by activity *B*.

These two events are independents. That is, there drawing does not affect one another.

Thus, we have:

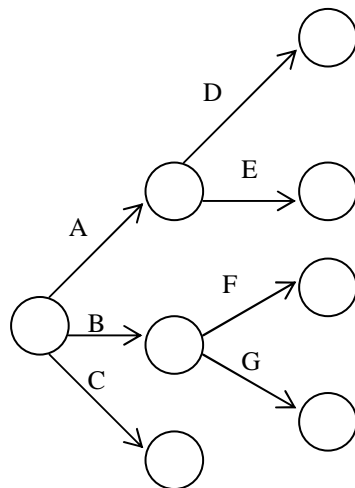

Note

Also the position of *D* and *E* can be interchanged depending on the relationships that may exist further.
Similarly, *F* and *G*.

Stage 3

Activity *H* is preceded by activities *C* and *F*. This implies that *C* and *F* must end at the same point before *H* can start. This can be achieved in the diagram by drawing the arrows of *C* and *F* to meet at the same node, then the arrow of *H* then takes off. Note that positions of *G* and *F* are interchange for proper connection.

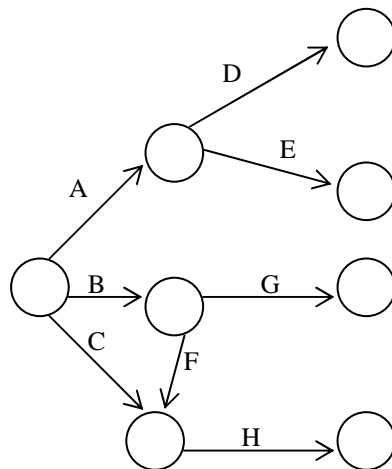

Stage 4

Activity *I* is preceded by activities *D*, *G* and *H*. This implies that *D*, *G* and *H* must end at the same point before *I* can start. This can be achieved drawing the arrows of *D*, *G* and *H* to meet at the same node, then the arrow of *I* is then drawn.

Thus:

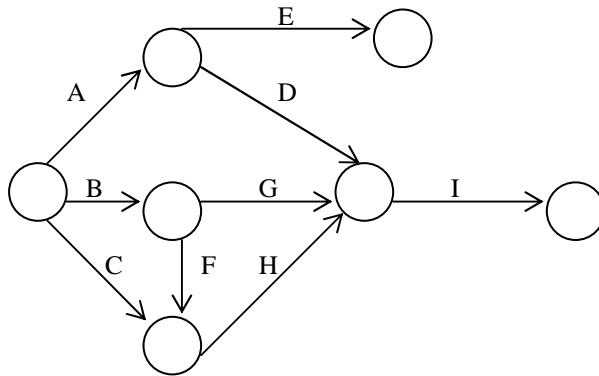

Note

Positions of *D* and *E* were interchanged for proper connection.

Since dangling is not allowed in Network diagram, hence we have below a complete Network diagram to the problem.

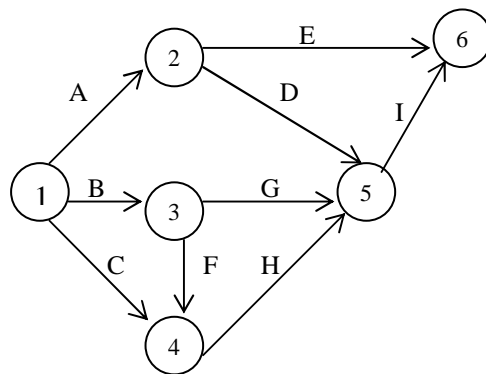

Note

- i. The events have been numbered 1–7 with 1 as start event and 7 as finish event.
- ii. The shape of the diagram does not matter but the logical arrangement must be correct.
- iii. Under examination condition, you are not expected to draw network diagram stage by stage as illustrated above; but a complete diagram is necessary. This is for illustration purpose, however, in drawing a network diagram, you will still have to go through those stages; but you need not break them down.

The various paths through the network are:

- a) $A \rightarrow E$
- b) $A \rightarrow D \rightarrow I$
- c) $B \rightarrow G \rightarrow I$
- d) $B \rightarrow F \rightarrow H \rightarrow I$
- e) $C \rightarrow H \rightarrow I$

EXAMPLE 4

Activities necessary for test launch.

Activity label	Description	Preceding Activity
<i>A</i>	Decide test market area	-
<i>B</i>	Agree marketing strategy	-
<i>C</i>	Agree production specification	-
<i>D</i>	Decide brand name	<i>B</i>
<i>E</i>	Prepare advertising plan	<i>A</i>
<i>F</i>	Agree advertising package	<i>E</i>
<i>G</i>	Design packaging	<i>D</i>
<i>H</i>	Production of test batch	<i>C</i>
<i>I</i>	Package and distribute	<i>G, H</i>
<i>J</i>	Monitor media support	<i>F, D</i>

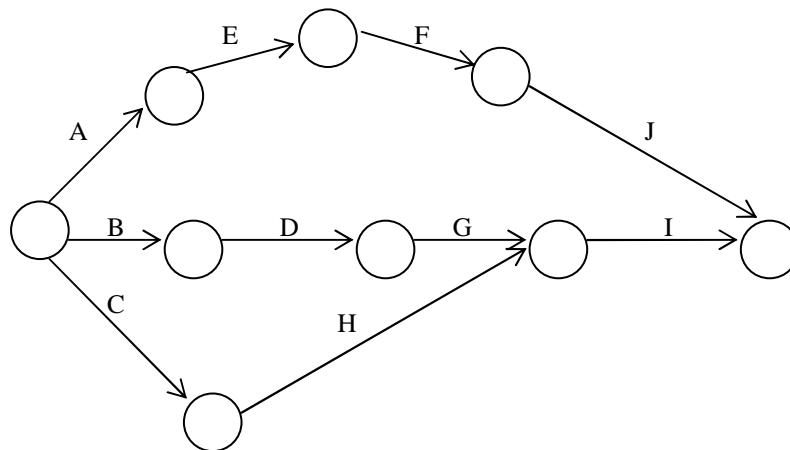

The various paths through the network are:

- a) $A \rightarrow E \rightarrow F \rightarrow J$
- b) $B \rightarrow D \rightarrow G \rightarrow I$
- c) $B \rightarrow D \rightarrow \text{Dummy} \rightarrow J$
- d) $C \rightarrow H \rightarrow I$

EXAMPLE 5

The network below shows a list of activities which must be done in order to complete a building project. The duration of each activity is in weeks.

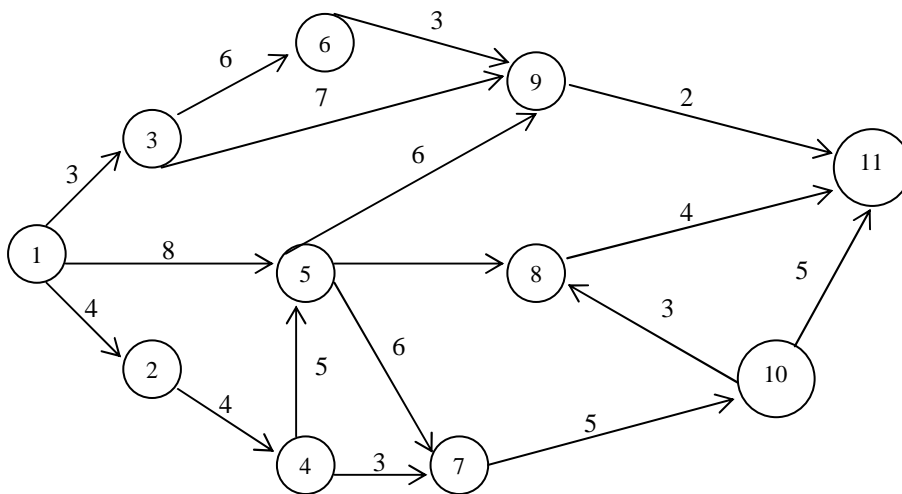

Required

Identify all possible paths together with their duration through the network.

SOLUTION

Paths	Duration
1. 1-2-4-7-10-11	$4+4+3+5+5 = 21$
2. 1-2-4-7-10-8-11	$4+4+3+5+3+4 = 23$
3. 1-2-4-5-7-10-11	$4+4+5+6+5+5 = 29$
4. 1-2-4-5-7-10-8-11	$4+4+5+6+5+3+4 = 31$
5. 1-2-4-5-8-11	$4+4+5+3+4 = 20$
6. 1-2-4-5-9-11	$4+4+5+6+2 = 21$
7. 1-3-9-11	$3+7+2 = 12$

Paths	Duration
8. 1-3-6-9-11	$3 + 6 + 3 + 2 = 14$
9. 1-5-9-11	$8 + 6 + 2 = 16$
10. 1-5-8-11	$8 + 3 + 4 = 15$
11. 1-5-7-10-11	$8 + 6 + 5 + 5 = 24$
12. 1-5-7-10-8-11	$8 + 6 + 5 + 3 + 4 = 26$

Time Analysis

○ Critical Path/Time Determination (CPA Method)

The critical path of a project or a network is the shortest time by which the whole project can be completed. In other words, it is the path of activities with the longest duration time. To determine the critical path, we use the following methods:

- a) Calculating Earlier Start Time (*EST*) and Latest Start Time (*LST*) which employ the forward and backward pass rule respectively. However, to be sure, you need to check that measure called total float is equal to zero (we shall deal with this in later section)
- b) Listing the possible paths in the network. The path with the longest duration is the critical path.

Calculating EST and LST

Each node is divided into three parts as shown below:

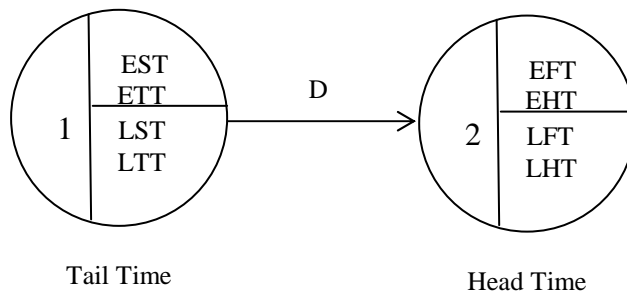

Numbers 1 and 2 are the event numbers while *D* is the activity duration.

Earliest Tail Time [*ETT*] \Rightarrow Earlier Start Time [*EST*].

Latest Tail Time [*LTT*] \Rightarrow Latest Start Time [*LST*].

Earliest Head Time [*EHT*] \Rightarrow Earlier Finish Time [*EFT*].
 Latest Head Time [*LHT*] \Rightarrow Latest Finish Time [*LFT*].

EXAMPLE 6

For the network diagram below use:

- i. Forward and backward pass method, and
- ii. Possible routes method to calculate the critical path method.

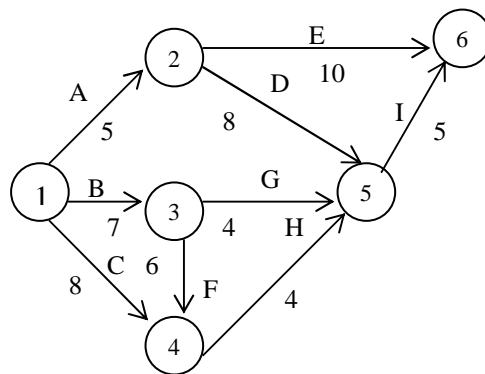

SOLUTION

- i. Forward Pass (*EST / EFT*)

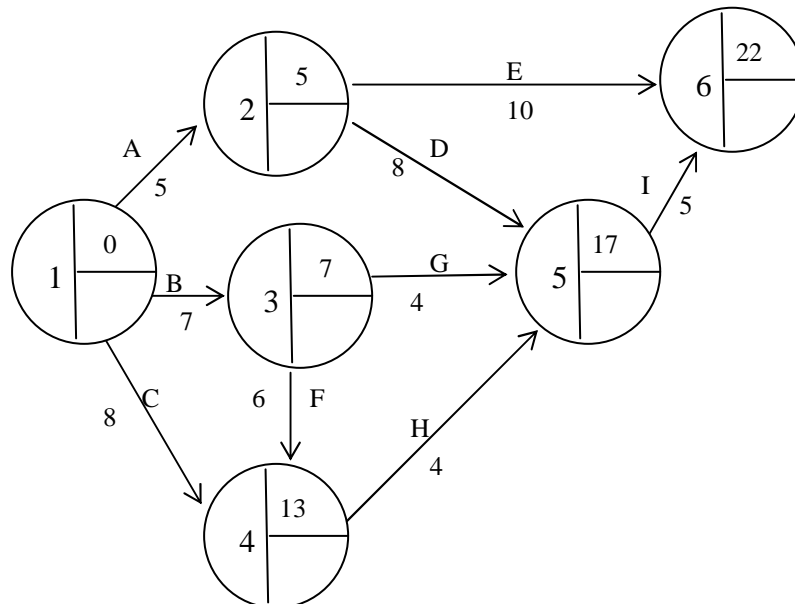

Note

- a) Node 1 is the start of events. Activities A , B and C start the event simultaneously. We usually start at the Earliest [EST] Time Zero [0] i.e. EST for activities A , B and C is 0.
- b) Node 2 is the end of event 1 (through A) and the start of event 2. Activities E and D will start after the completion of activity A . Therefore, EST for activities E and D is the EST of activity A plus the duration of activity A i.e. $(0 + 5 = 5)$.
- c) Node 3 is the end of event 1 (through B) and the start of event 3. Activities G and F will start after the completion of activity B . Therefore, EST for activities G and F is the EST of activity B plus the duration of activity B i.e. $(0 + 7 = 7)$.
- d) Node 4 is the end of event 1 (through C) and event 3 (through F). Activity H will start after the completion of activities C and F . Note, however that these two activities might end at different times. If these occur, we select the maximum of these completion times. This will then be the EST for activity H .

Hence:

Completion time for activity C is:

EST for activity C plus duration of activity C i.e.
 $(0 + 8 = 8)$.

Completion time for activity F is:

EST for activity F plus duration of activity F i.e.
 $(7 + 6 = 13)$.

The maximum is 13. Therefore, the EST for activity H at node 4 is 13.

- e) Node 5 is the end of events 2 (through D), 3 (through G) and 4 (through H). Activity I will start after the completion of activities D , G and H . Following the same procedure as in (d) above, the EST for activity I is the maximum of the completion time for activities D , G or H .

Hence:

Completion time for activity D is:

EST for activity D plus duration of activity D i.e.
 $(5 + 8 = 13)$.

Completion time for activity G is:

EST for activity *G* plus duration of activity *G* i.e
(7 + 4 = 11).

Completion time for activity *H* is:

EST for activity *H* plus duration of activity *H* i.e
(13 + 4 = 17).

Of these, the maximum is 17. Therefore, the *EST* for activity *I* at node 5 is 17.

- f) Node 6 is the end of project. Here, we talk of *EFT* [Earliest Finish Time]. Two activities (*E* and *I*) finished at node 6. Following the same procedure as in (d) above, the *EFT* at node 6 will be the maximum of the completion time for activities *E* or *I*.

Hence:

Completion time for activity *E* is:

EST for activity *E* plus duration of activity *E* i.e
(5 + 10 = 15).

Completion time for activity *I* is:

EST for activity *I* plus duration of activity *I* i.e
(17 + 5 = 22).

Of these, the maximum is 22. Therefore, the *EFT* / project duration is 22 days.

Note

From the above diagram, you will notice that the *EFT* of an activity is the *EST* of the preceding activity.

Backward Pass (LST)

This time around, we start from the last event (node 6) backward.

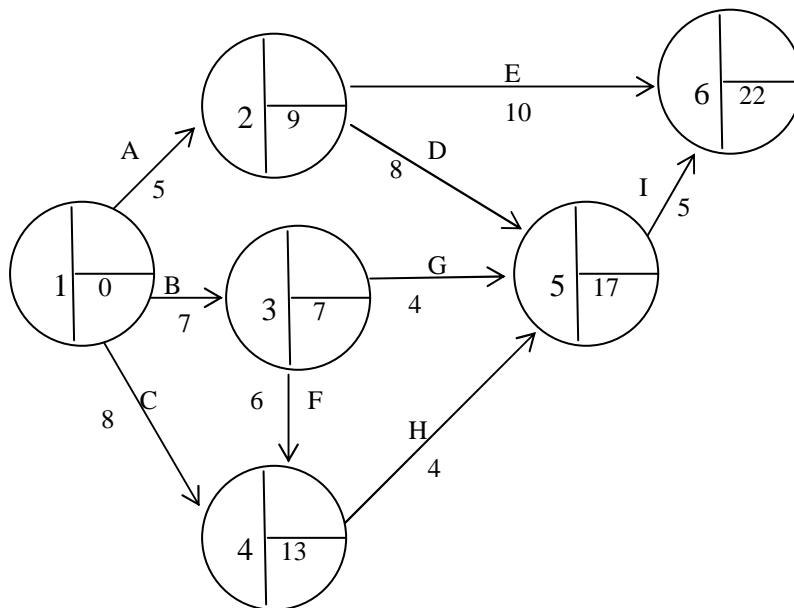

Note

- a. At Node 6, the *LFT* is the same as the *EFT* .
Therefore, $LFT = 22$.
- b. At Node 5, the *LST* of activity *I* is *LFT* at Node 6 minus Duration of activity *I* i.e. $(22 - 5 = 17)$.
- c. At Node 4, the *LST* of activity *H* is *LST* at Node 5 minus Duration of activity *H* i.e. $(17 - 4 = 13)$.
- d. At Node 3, this is the *LST* for activities *G* and *F* .
Since, we have more than one activity in this situation, the *LST* of the minimum of the two shall be consider.
 - *LST* at Node 3 through *G* is:
LST at Node 5 minus Duration of activity *G* i.e.
 $(17 - 4 = 13)$.
 - *LST* at Node 3 through *F* is:
LST at Node 4 minus Duration of activity *F* i.e.
 $(13 - 6 = 7)$.
 Of these, 7 is the least. Therefore, the *LST* at Node 3 is 7 .
- e. At Node 2, this is the *LST* for activities *D* and *E* .
Using the same procedure as in (d) above:

- *LST* at Node 2 through *D* is:
LST at Node 5 minus Duration of activity *D* i.e.
(17 – 8 = 9).
- *LST* at Node 2 through *E* is:
LFT at Node 6 minus Duration of activity *E* i.e.
(22 – 10 = 12).

Of these, 9 is the least. Therefore, the *LST* at Node 2 is 9.

- f. At Node 1, this is the *LST* for activities *A*, *B* and *C*.
Using the same procedure as in (d) above:

- *LST* at Node 1 through *A* is:
LST at Node 2 minus Duration of activity *A* i.e.
(9 – 5 = 4).
- *LST* at Node 1 through *B* is:
LST at Node 3 minus Duration of activity *B* i.e.
(7 – 7 = 0).
- *LST* at Node 1 through *C* is:
LST at Node 1 minus Duration of activity *C* i.e.
(13 – 8 = 5).

Of these, 0 is the least. Therefore, the *LST* at Node 1 is 0.

Note

The *LFT* of an activity is the same as the *LST* of the preceding activity.

Combined Diagram showing forward and backward Pass

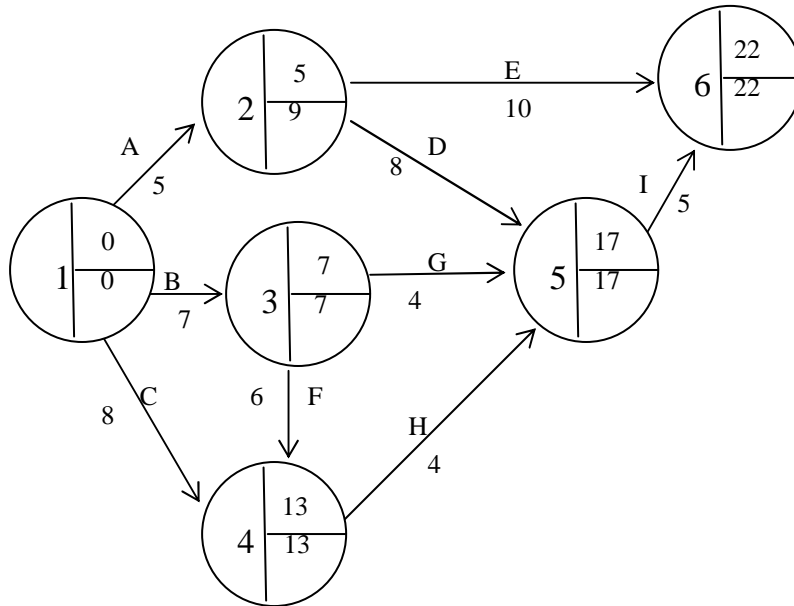

The critical paths are paths that gave equal *EST/EFT* and *LST/LFT* which are:

- $B \rightarrow G \rightarrow I$
- $B \rightarrow F \rightarrow H \rightarrow I$
- $C \rightarrow H \rightarrow I$.

ii. **Possible Path Method**

From the diagram, the possible paths with duration are:

Paths	Duration
a) $A \rightarrow E$	$5 + 10 = 15$
b) $A \rightarrow D \rightarrow I$	$5 + 8 + 5 = 18$
c) $B \rightarrow G \rightarrow I$	$7 + 4 + 5 = 16$
d) $B \rightarrow F \rightarrow H \rightarrow I$	$7 + 6 + 4 + 5 = 22$
e) $C \rightarrow H \rightarrow I$	$8 + 4 + 5 = 17$

The critical paths are path(s) with the highest duration
i.e. $B \rightarrow F \rightarrow H \rightarrow I$.

Float or Spare Time

Floats are spare time (idle time or unused time) available on non-critical activities. Activities on the critical paths always have zero (0) or no float.

- **Types of Float**

There are three types of float. They are:

- i. Total float
- ii. Free float
- iii. Independent float.

- **Total Float**

This is the amount of time a path of activity could be delayed without affecting the overall project duration.

The measure is as follows:

$$\text{Total float (TF)} = LFT - EST - D .$$

- **Free Float**

This is the amount of time an activity can be delayed without affecting the commencement of a subsequent activity at its Earliest Start Time, but may affect float of previous activity.

The measure is as follows:

$$\text{Free float (FF)} = EFT - EST - D .$$

- **Independent Float**

This is the amount of time an activity can be delayed when all preceding activities are completed as late as possible and all succeeding activities are completed as early as possible.

The measure is as follows:

$$\text{Independent float (IF)} = EFT - LST - D .$$

EXAMPLE 7

With reference to Example 4, calculate the total float, free float and independent float for each of the activity.

SOLUTION

Activity	<i>D</i> Duration	<i>EST</i>	<i>LST</i>	<i>EFT</i>	<i>LFT</i>	<i>TF</i>	<i>FF</i>	<i>IF</i>
A	5	0	0	5	9	4	0	0
B	7	0	0	7	7	0	0	0
C	8	0	0	13	13	5	5	5
D	8	5	9	17	17	4	4	0
E	10	5	9	22	22	7	7	3
F	6	7	7	13	13	0	0	0
G	4	7	7	17	17	6	6	6
H	4	13	13	17	17	0	0	0
I	5	17	17	22	22	0	0	0

Visual Representation of Floats

Consider the following activity *P* :

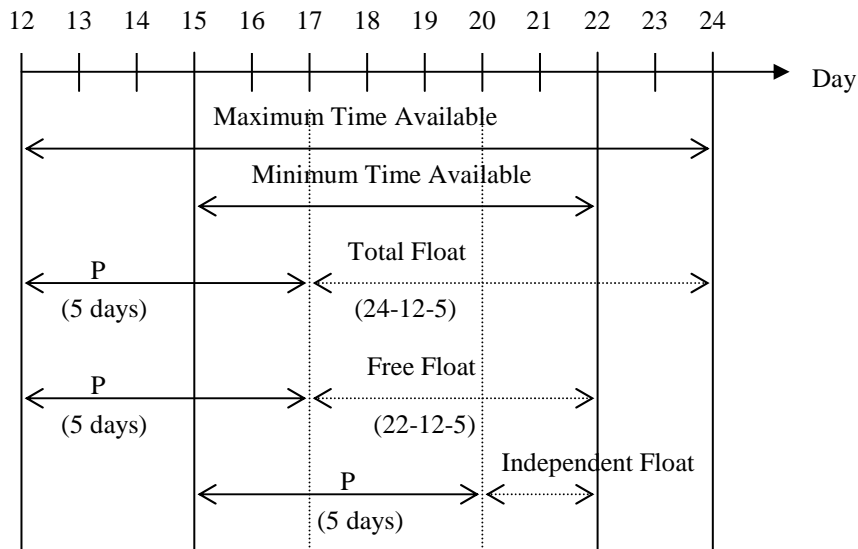
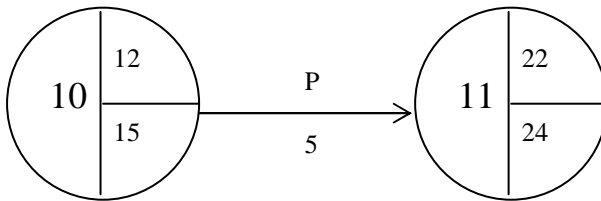

It can be seen that total float is seven days, free float is five days and independent float is two days.

Project Time Reduction

One important aspect of project management is looking at ways of reducing the overall project time at an acceptable cost. Where an activity involves some chemical process, it may be impossible to reduce the time taken successfully, but in most other activities the duration can be reduced at some cost. Time reduction may be achieved by using a (different) machine, adopting a new method of working, allocating extra personnel to the task or buying in a part or a service. The minimum possible duration for an activity is known as the crash duration. Considerably, care must be taken when reducing the time of activities on the network to make sure that the activity time is not reduced by so much that it is no longer critical. New critical paths will often arise as this time reduction exercise continues.

The project given in the table below will have a critical path consisting of activities *A* and *D*, a project time of 18 days and a cost of #580 if the normal activity times are used as shown in figure below.

Activity	Duration (Days)	Preceding Activities	Cost (#)	Crash duration (Days)	Crash cost (#)
<i>A</i>	8	-	100	6	200
<i>B</i>	4	-	150	2	350
<i>C</i>	2	<i>A</i>	50	1	90
<i>D</i>	10	<i>A</i>	100	5	400
<i>E</i>	5	<i>B</i>	100	1	200
<i>F</i>	3	<i>C, E</i>	80	1	100

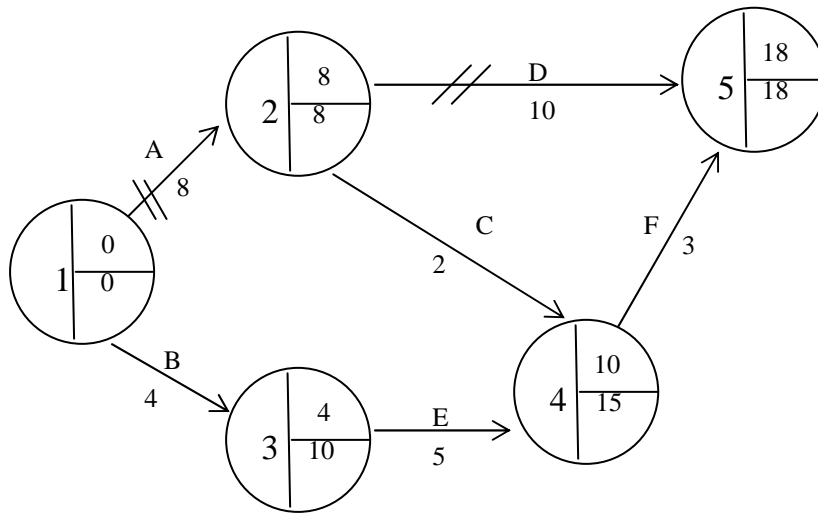

Critical path: $A \rightarrow D$.

Cost = #580.

Since cost is likely to be of prime importance in deciding whether or not to take advantage of any feasible time reductions, the first step is to calculate the cost increase per time period saved for each activity. This is known as the slope for each activity.

For activity A, this would be: $\frac{\text{Increase in cost}}{\text{Decrease in time}}$

$$= \frac{100}{2} = 50.$$

The slopes for each activity are shown in the table below:

Activity	A	B	C	D	E	F
Slope	50	100	40	60	25	10

A second step is to find the free float time for each non-critical activity. Free float times are shown in the table below:

Activity	EFT	EST	D	Free float
B	4	0	4	0
C	10	8	2	0
E	10	4	5	1
F	18	10	3	5

To reduce the project time, select that activity on the critical path with the lowest slope (here, A) and note the difference between its normal duration and its crash duration (here, $8 - 6 = 2$). Look for the smallest (non-zero) free float time (here, 1 for activity E), select the minimum of these two numbers and reduce the chosen activity by this amount (here, A now has a reduction of 7). Cost will increase by the time reduction multiplied by the slope (1×50). It is now necessary to reconstruct the network as shown in figure below.

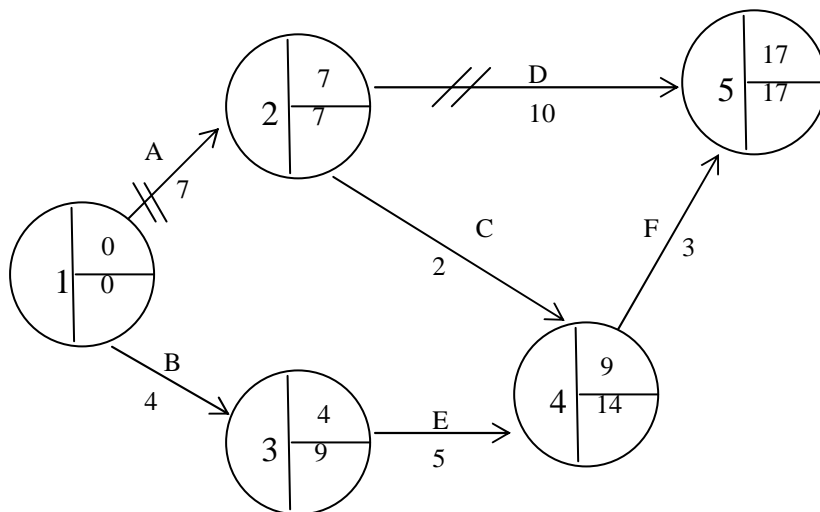

Critical path: $A \rightarrow D$.
 Cost = #580 + $(1 \times \#50)$ = #630.

The procedure is now repeated and the new free float times are shown in the table below.

The activity on the critical path with the lowest slope is still A, but it can only be reduced by one further time period. If this is done, we have the situation shown in the figure below:

Activity	EFT	EST	D	Free float
B	4	0	4	0
C	9	7	2	0
E	9	4	5	0
F	17	9	3	5

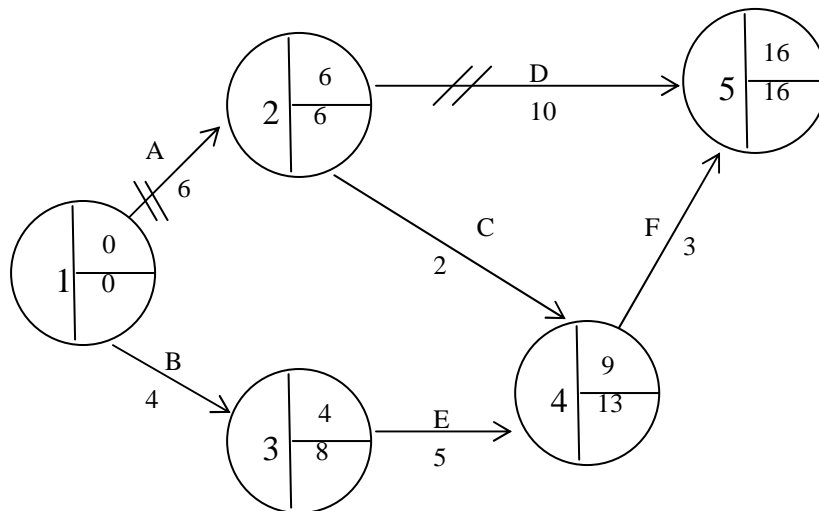

Crash duration.

Critical path: $A \rightarrow D$.

Cost = #630 + (1 × #50) = #680.

Any further reduction in the project time must involve activity D, since activity A is now at its crash duration time. If we reduced activity D to six days (i.e. 10 – 4), we have the situation shown in figure below:

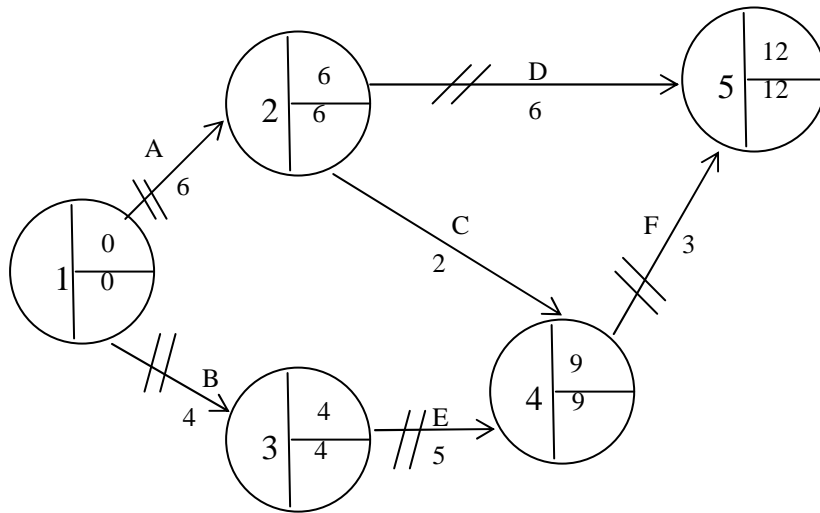

Critical path: $A \rightarrow D$ and $B \rightarrow E \rightarrow F$
 Cost = #680 + (4 × #60) = #920.

There are now two critical paths through the network and thus for any further reduction in the project time, it will be necessary to reduce both of these by the same amount. On the original critical path, only activity D can be reduced and only by 1 time period at a cost of #60. For the second critical path, the activity with the lowest slope is F , at a cost of #10. If this is done, we have the situation in figure below:

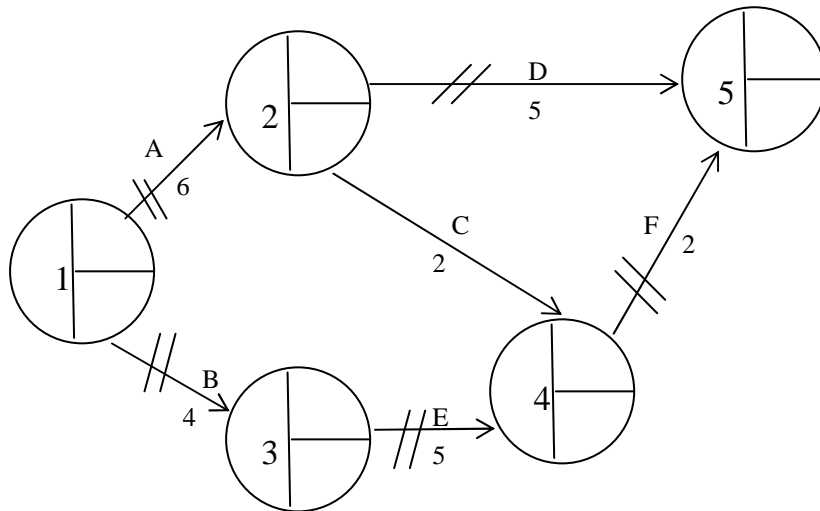

Crash duration.

Critical path: $A \rightarrow D$ and $B \rightarrow E \rightarrow F$

Cost = #920 + (1 × #60) + (1 × #10) = #990.

There are number of variations on this type of cost reduction problem and again, we have just tried to illustrate the general principles.

Uncertainty

So far, in all our calculations, we have assumed a certainty about the time required to complete an activity or activities. In practice, there will always be some uncertainty about the times taken by future activities. It is known that many activities are dependent upon the weather, and the element of chance is to be expected e.g. when building a wall or completing a long sea journey.

Other types of activity are also subject to uncertainty. How certain can we be, that new software will work or be understood first time? How certain can we be, that the response rate will allow interviewing to be completed in an exact time?

To manage this uncertainty, we work with three estimates of time: Optimistic, Most likely and Pessimistic. Activity time is usually assumed to follow the beta distribution (which need not concern us too much, here). The mean and the variance for each activity given the three time estimates and the assumption of the beta distribution is:

$$\text{Mean} = \mu = \frac{O + 4M + P}{6}.$$

$$\text{Variance} = \sigma^2 = \left(\frac{O - P}{6} \right)^2.$$

Where O is the optimistic time, M is the most likely time and P is the pessimistic time.

However, when managing a project, we are particularly interested in the overall duration, which is the sum of individual activity times. The sum of activity times (which individually follow the beta distribution) follows the normal distribution – an important statistical result. If we now consider the critical path:

The mean = the sum of activity means.
 The variance = the sum of activity variances.

An example is given in the table below where the critical path is given by the activities *A*, *D*, *H* and *K*.
 The mean of the critical path is $\mu = 21.666$ and the variance $\sigma^2 = 2.694$. The standard deviation is $\sigma = 1.641$.

Activity	Optimistic (<i>O</i>)	Most likely (<i>M</i>)	Pessimistic (<i>P</i>)	Mean	Variance
<i>A</i>	8	10	14	10.333	1.000
<i>D</i>	3	4	6	4.167	0.250
<i>H</i>	2	3	6	3.333	0.444
<i>K</i>	1	3	7	<u>3.333</u>	<u>1.000</u>
				<u>21.166</u>	<u>2.694</u>

We are now able to produce a confidence interval (and make other probability statements).

The 95% confidence interval for the total project time (activities *A*, *D*, *H* and *K*):

$$\begin{aligned}
 &= \mu \pm 1.96\sigma \\
 &= 21.666 \pm 1.96 \times 1.641 \\
 &= 21.666 \pm 3.216.
 \end{aligned}$$

This is a simplified example where a single critical path *A*, *D*, *H* and *K* has been considered. However, in practice, as a more complex project proceeds, some activities will take longer than expected and others, a shorter time. The critical path can therefore shift as the project progress, and needs to be kept under review. The identification of the critical path and the calculations based on the means are expected outcomes and subject to chance.

To find the probability that a project will be completed on the scheduled date, we use the standard normal distribution:

$$Z = \frac{\text{Scheduled date} - \text{Expected date of completion}}{\text{Standard deviation}}$$

$$= \frac{\text{Scheduled date} - \mu}{\sigma}$$

Resource and Networks

The usefulness of networks is not confined only to the time and cost factor which have been discussed so far. Considerable assistance in planning and controlling the use of resources can be given to management by appropriate devicement of the basic network techniques.

Project Resources

The resources (men of varying skills, machines of all type, the required materials, finance, and space) used in a project are subject to varying demands and loadings as the project proceeds. Management need to know what activities and what resources are critical to the project duration and if resources limitations (e.g. shortage of materials, limited number of skilled craftsmen might delay the project. They also wish to ensue, as far as possible, constant work rates to eliminate paying overtime at one stage of a project and having short time working at another stage.

Resources Schedule Requirements

To be able to schedule the resource requirements for a project, the following details are required:

- a. The customary activity times, descriptions and sequences as previously described.
- b. The resource requirements for each activity showing the classification of the resource and the quantity required.
- c. The resources in each classification that are available to the project variations in availability are likely during the project life, this must also be specified.
- d. Any management impositions that need to be considered e.g. which activities may or may not be split or any limitations on labour mobility.

Resources Scheduling Example

A simple project has the following time and resource data (for simplicity, only one resource of labour is considered but similar principles would apply to other types of inter-changeable resources).

Project Data

Activity	Preceding Activity	Duration (Days)	Labour Requirement
<i>A</i>	-	1	2 men
<i>B</i>	-	2	1 man
<i>C</i>	<i>A</i>	1	1 man
<i>D</i>	-	5	1 man
<i>E</i>	<i>B</i>	1	1 man
<i>F</i>	<i>C</i>	1	1 man

Resource constraint, 2 men only available.

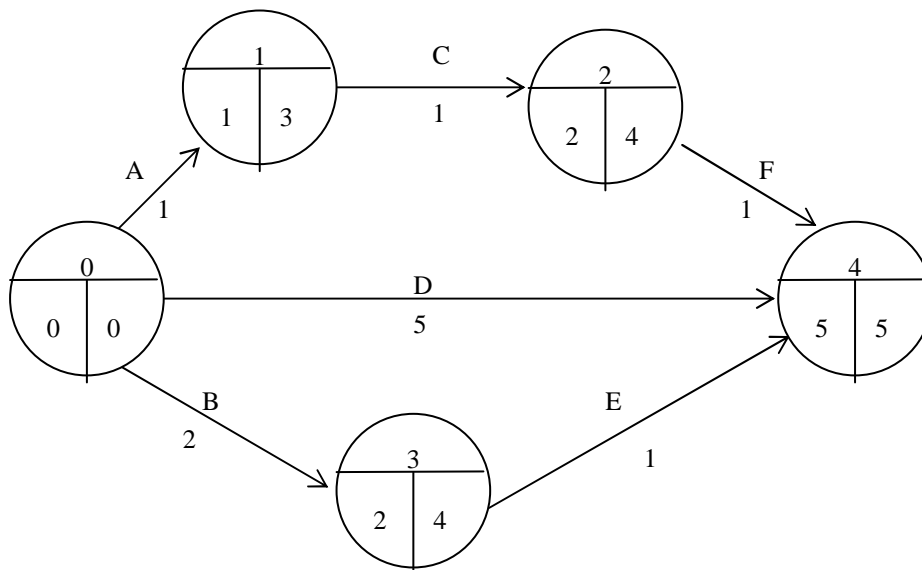

Critical Path – Activity D – Duration Days

(Without taking account of the resource constraint).

Resource Scheduling Steps:

- i. Draw the activity times on a bar chart based on their ESTs.

Time Scaled Network

- ii. Based on the time bar chart, prepare a Resource Aggregation Profile, total resource requirements in each time period.

Resource Aggregation Profile based on EST's

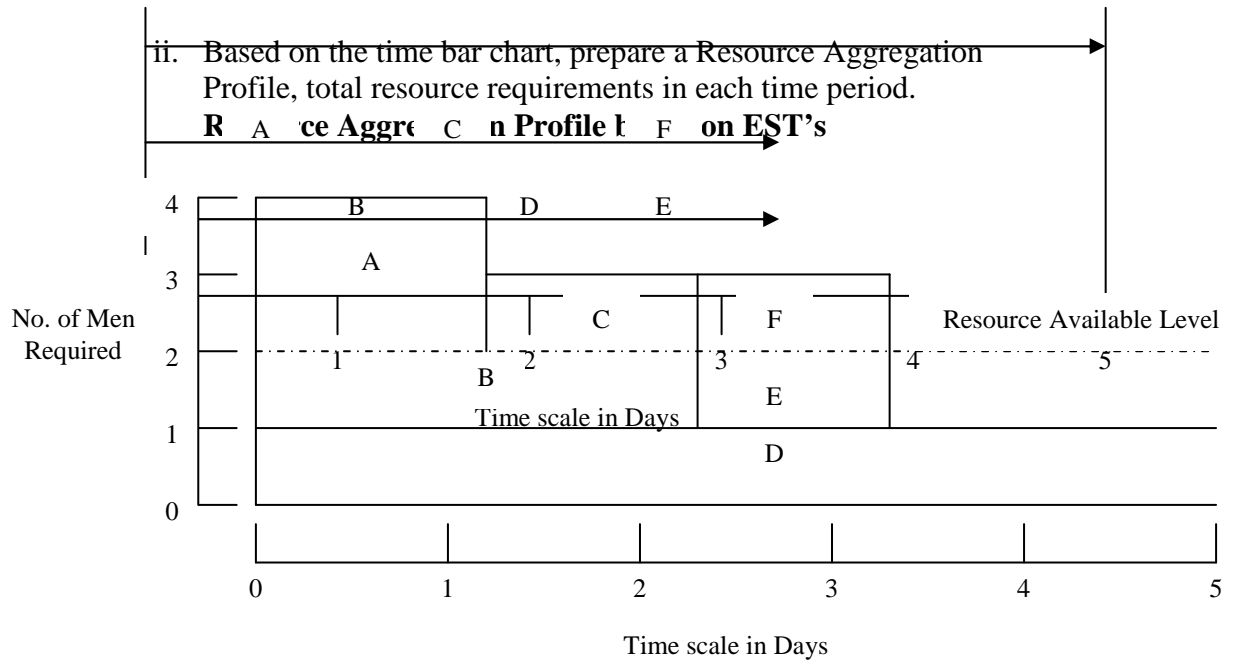

- iii. Examination of the above profile shows that, at times more resources are required than are available if activities commence at their EST's. The EST's, LST's on the network show that floats is available for activities A, C, F, B and E. Having regard to these floats, it is necessary to 'smooth out' the resource requirements so that the resources required do not exceed the resource constraint i.e. delay the commencement of activities (within their float) and this procedure is still not sufficient, then delay the project as a whole. Carrying out this procedure results in the following resource profile.

Resource Allocation Profile – with 2 men Constraint

Note

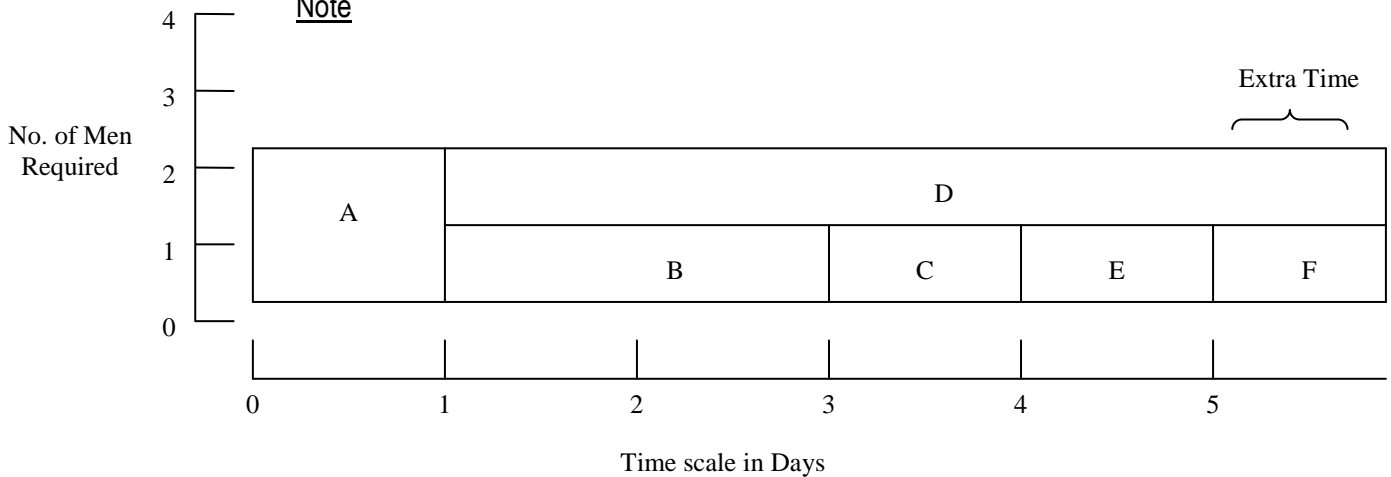

This procedure is sometimes termed RESOURCE LEVELLING.

- iv. Because of the resource constraint of 2 men, it has been necessary to extend the project duration by 1 day. Assume that management state that the original project duration (5 days) must not be extended and they require this to be achieved with the minimum extra resources. In such cases, a similar process varying activity start times within their float is carried out, resulting in the following resources profile.

4.0. CONCLUSION

As in the summary

5.0. SUMMARY

1. Most managers are always involved in one project or the other.
2. A project may be the large and complex, like building a shopping complex or small scale like purchasing computers for a business out fit.
3. Projects are expected to be delivered on time, within the available budget and as target with respect to key aim, objectives are quality of standard.
4. Some of the characteristics of a project include: use of large personnel as team workers, financially demanding, cost consuming is different from other routine activities, has a completion date involves a set related activities.
5. A project is a sequence of jobs which has a starting point and completion time it aims at ensuring completion of project on time and at minimal cost
6. An activity is a unit job within a project
7. An event is a movement is time involving the time when a job is concluding and another is about to begin.
8. A network diagram shows the logical sequence of activities in a job.
9. In developing the network model, we first identify the key activities and their time estimates and then identify the sequencing of activities in terms of the independencies.

10. In a network diagram there must be a starting and end, note, each event must have at least one preceding activity and at least one subsequent activity. Also two events can only be joined by one point and numbering is such that then start has the least number and the stop the highest number.
11. Critical activities are activities that must be completed at the stipulated time to avoid delay in the project.
12. The CPM is deterministic while PERT is probabilities in terms of time estimate.
13. In networking analysis we construct a network and computer time and cost estimate.
14. The path with the highest time is the critical path.
15. The time estimates of the forward pass of a network give us the cumulative durations of jobs in a project from the start to the end of the project. The last value of the time estimate of the forward pass gives us the completion time of the project. Conventionally, the first time estimate of the forward pass is 0.
16. Computations of the Earliest start time (EST) and the Earliest finish time (EFT) for each of the activities in the network involve a forward pass through the network.
17. Computations of the latest finish time (LFT) and the latest start time (LST) involve a backward pass through the network.
18. The time estimates for the backward pass are computed backward from the end to the beginning of the project using the computed time estimates for the forward pass. Conventionally, we start with the least time estimate of the forward pass.
19. A float is a measure of delay in executing a non critical job which will not affect the overall project completion time.

20. Total float, free float and independent float are three types of floats. They are also known as slacks of activities.
21. The activities for which the free float, total float and independent float are each equal to zero from the critical path.
22. The project is crashed if it is expedited at short time and is usually at higher cost.
23. The Crash slope is give by $\frac{\text{Crash cost} - \text{normal Cost}}{\text{Normal Time} - \text{Crash Time}}$
24. Optimistic time (a) is the minimum time to complete an activity in a project if every things goes on as planned.
25. Pessimistic time (b) Is the minimum time to complete a project and is brought about if everything goes wrong.
26. Most likely time (m) is the normal time to complete an activity in a project.
27. The expected or mean time to complete an activity is given as $(a + 4m + b) / 6$ where a is the optimistic time b is the pessimistic time and m the cost likely time. The variance $\left(\frac{b-a}{6}\right)^2$.
28. The mean of the critical activity in a project is the total completion time.
29. If we add up all the variances of the critical activities in a project, we get an estimate of variance of the critical path.
30. Normality is assumed on the PERT analysis and we can use the distribution to compute probability of completing a project on or before a specified time.

6.0. TUTOR MARKED ASSIGNMENT

Examples (1-7) can be retried without referring to the solutions therein.

7.0. REFERENCES/FURTHER READINGS

1. Operations Research. By Prem Kumar Gupta and D.S. Hira
2. Operations Research. (Problem Solvers) By Research and Education Association.
25. Statistics and Operations Research. By Debashis Dutta
26. Operations Research By). O.T. Arowolo and G.O. Lawal

UNIT3

THE SEQUENCING PROBLEMS

CONTENTS

15.0	Introduction
16.0	Objective
17.0	Main Content
17.1	Terms commonly used
17.2	Types of Sequencing problems
17.3	Priority Sequencing
17.4	Sequencing n jobs through two machines
17.5	n jobs m machines case
17.6	Two jobs 3 machines case
18.0	Conclusion
19.0	Summary
20.0	Tutor Marked Assignment
21.0	References/Further

1.0 INTRODUCTION

Every organization wants to utilize its productive systems effectively and efficiently and wants to maximize its profit by meeting the delivery deadlines. A number of jobs involving many operations have to be performed and there are limited resources in terms of plant and machinery on which the jobs have to be performed. It is necessary that available facilities are optimally utilized and they are loaded, scheduled and sequenced properly.

A sequence is the order in which different jobs are to be performed. When there is a choice that a number of tasks can be performed in different orders, then the problem of sequencing arises. Such situations are very often encountered by manufacturing units, overhauling of equipments or aircraft engines. Maintenance schedule of a large variety of equipment used in a factory, customers in a bank or car servicing garage and so on.

The basic concept behind sequencing is to use the available facilities in such a manner that the cost (and time) is minimized. The sequencing theory has been developed to solve difficult problems of using limited number of facilities in an optimal manner to get the best production and minimum costs.

2.0 OBJECTIVES

At the end of this unit readers will be able to:

- Describe the concept of sequencing
- State the assumptions made in the sequencing problem
- Define the terminologies used sequencing problem

- Do “Processing Job through different number of machine”
- Do “Processing of two job through m machines and n job through m machines”

3.0 MAIN CONTENT

3.1 TERMS COMMONLY USED

1. **Job.** These have to be sequenced, hence there should be a particular number of jobs (groups of tasks to be performed) say n to be processed.
2. **Machine.** Jobs have to be performed or processed on machines. It is a facility which has some processing capability
3. **Loading.** Assigning of jobs to facilities and committing of facilities to jobs without specifying the time and sequence.
4. **Scheduling.** When the time and sequence of performing the job is specified it is called scheduling.
5. **Sequencing.** Sequencing of operations refers to a systematic procedure of determining the order in which a series of jobs will be processed in a definite number, say k , facilities or machines.
6. **Processing Time.** Every operation that is required to be performed requires definite amount of time at each facility or machine when processing time is definite and certain, scheduling is easier as compared to the situation in which it is not known
7. **Total Elapsed Time.** It is the time that lapses between the starting of first job and the completion of the last one.
8. **Idle Time.** The time for which the facilities or machine are not utilized during the total elapsed time.
9. **Technological Order.** It is the order which must be followed for completing a job. The requirement of the job dictates in which order various operations have to be performed, for example, painting cannot be done before welding.
10. **Passing not allowed.** If ' n ' jobs have to be processed through ' m ' machines in a particular order of M_1, M_2, M_3 then each job will go to machine M_1 first and then to M_2 and finally to M_3 . This order cannot be passed.
11. **Static arrival pattern.** If all the jobs to be done are received at the facilities simultaneously.
12. **Dynamic arrival pattern.** Here the jobs keep arriving continuously.

ASSUMPTIONS

In sequencing problems, the following assumptions are made:-

- (i) All machines can process only one job at a time

- (ii) No time is wasted in shifting a job from one machine to other
- (iii) Processing time of job on a machine has no relation with the order in which the job is processed
- (iv) All machines have different capability and capacity
- (v) All jobs are ready for processing
- (vi) Each job when put on the machine is completed
- (vii) All job are processed in specified order as soon as possible

3.2 TYPES OF SEQUENCING PROBLEMS

The following type of sequencing problems will be discussed in the chapter:-

- (a) n jobs one machine case
- (b) n jobs two machine case
- (c) n jobs ' m ' machine case
- (d) Two jobs ' m ' machine case

The solution of these problems depends on many factors such as:

- (a) The number of jobs to be scheduled
- (b) The number of machines in the machine shop
- (c) Types of manufacturing facility (slow shop or fast shop)
- (d) Manner in which jobs arrive at the facility (static or dynamic)
- (e) Criterion by which scheduling alternatives are to be evaluated

As the number of jobs (n) and the of machines (m) increases, the sequencing problems become more complex. In fact, no exact or optimal solutions exist for sequencing problems with large n and m simulation seems to be a better solution techniques for real life scheduling problems

n – JOBS ONE MACHINE CASE

This case of a number of jobs to be processed on one facility is very common in real life situations. The number of cars to be serviced in a garage, number of engines to be overhauled in one workshop, number of patients to be treated by one doctor, number of different jobs to be machined on a lathe etc are the cases which can be solved by using the method under study. In all such cases we are all used to 'first come first served' principle to give sense of satisfaction and justice to the waiting jobs. But if this is not the consideration, it is possible to get more favourable results in the interest of effectiveness and efficiency. Following assumptions are applicable:-

- (a) The job shop is static
- (b) Processing time of the job is known.

The implication of the above assumption that job shop is static will mean that new job arrivals do not disturb the processing of n jobs already being processed and the new job **arrivals** wait to be attended to in next batch.

SHORTEST PROCESSING TIME (SPT) RULE

This rule says that jobs are sequenced in such a way that the job with least processing time is picked up first, followed by the job with the next smallest processing time (SPT) and so on. This is referred to as shortest processing time sequencing. However, when the importance of the jobs to be performed varies, a different rule called Weight – Scheduling (WSPT) rule is used, weights are allotted to jobs, greater weight meaning more important job. Let W_i be the weight allotted. By dividing the processing time by the weight factor, the tendency to move important job to an earlier position in the order is achieved.

$$\text{Weighted Mean Flow Time, WMFT} = \frac{\sum_{i=1}^n W_i f_i}{\sum_{i=1}^n W_i}$$

Where $f_i =$ flow time of job $i = W_i + t_i$

$t_i =$ processing time of job i

WSPT rule for minimizing weighted mean-flow time (WMFT) puts n jobs in a sequence such that

$$\frac{t[1]}{W[1]} \leq \frac{t[2]}{W[2]} \leq \dots \leq \frac{t[n]}{W[n]}$$

The numbers in brackets above define the position of the jobs in the optima sequence

Example 1. Consider the 8 jobs with processing times, due dates and importance weights as shown below.

8 jobs one machine case data

Task (i)	Processing Time (t_i)	Due Date (d_i)	Importance Weight (W_i)	$\frac{t_i}{W_i}$
1	5	15	1	5.0
2	8	10	2	4.0
3	6	15	3	2.0
4	3	25	1	3.0
5	10	20	2	5.0
6	14	40	3	4.7
7	7	45	2	3.5
8	3	50	1	3.0

From processing time t_i in the table the SPT sequence is 4 – 8 – 1 – 3 – 7 – 2 – 5 – 6 resulting in completion of these jobs at time 3, 6, 14, 20, 27, 36, 46, 60 respectively

$$\text{WMFT} = \frac{3 + 6 + 14 + 20 + 27 + 36 + 46 + 60}{8} = 26.5 \text{ hours}$$

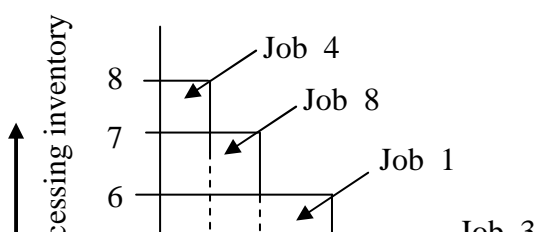

The sequence is shown graphically above from which the number of tasks waiting as in-process inventory is seen to be 8 during 0-3, 7 during 3-6, 6 during 6-14, 5 during 14-20, 4 during 20-27, 3 during 27-36, 2 during 36 – 46 and one during 46-60. Thus the average inventory is given by

$$\frac{8 \times 3 + 7 \times 3 + 6 \times 8 + 5 \times 6 + 4 \times 7 + 3 \times 9 + 2 \times 10 + 1 \times 14}{60}$$

$$= \frac{24 + 21 + 48 + 30 + 28 + 27 + 20 + 14}{60} = \frac{212}{60} = 3.53 \text{ jobs}$$

WSPT

If the important weights W_i were to be considered the WSPT could be used to minimize the Weighted Mean Flow Time (WMFT) to yield the sequence 3-4-8-2-7-6-5-1. This result by first choosing job with minimum $\frac{t_i}{W_i}$ in the table. The respective flow time of jobs in this sequence are 6, 9, 12, 21, 28, 42, 52, 58. Mean flow time is hours

$$\text{WMFT} = \frac{6 \times 3 + 9 \times 1 + 12 \times 1 + 21 \times 3 + 28 \times 2 + 48 \times 3 + 52 \times 2 + 58 \times 1}{3 + 1 + 1 + 3 + 2 + 3 + 2 + 1}$$

$$= \frac{18 + 9 + 12 + 63 + 56 + 126 + 104 + 58}{16} = \frac{446}{16} = 27.85 \text{ hours}$$

Example 2. Eight jobs A, B, C, D, E, F, G arrive at one time to be processed on a single machine. Find out the optimal job sequence, when their operation time is given in the table below.

Job (n)	Operation time in minutes
A	16
B	12
C	10
D	8
E	7
F	4
G	2
H	1

Sol. For determining the optimal sequence, the jobs are selected in a non-descending operation time as follows.

Non-decreasing operation time sequence is $H \rightarrow G \rightarrow F \rightarrow E \rightarrow D \rightarrow C \rightarrow B \rightarrow A$

Total processing time

$$H = 1$$

$$G = 1 + 2 = 3$$

$$F = 1 + 2 + 4 = 7$$

$$E = 1 + 2 + 4 + 7 = 14$$

$$D = 1 + 2 + 4 + 7 + 8 = 22$$

$$C = 1 + 2 + 4 + 7 + 8 + 10 = 32$$

$$B = 1 + 2 + 4 + 7 + 8 + 10 + 12 = 44$$

$$A = 1 + 2 + 4 + 7 + 8 + 10 + 12 + 16 = 60$$

$$\text{Average processing time} = \text{Total time/number of Jobs} = 483/8 = 60.375 \text{ minutes.}$$

In case the jobs are processed in the order of their arrival i.e. $A \rightarrow B \rightarrow C \rightarrow D \rightarrow E \rightarrow F \rightarrow G \rightarrow H$ the total processing time would have been as follows:-

$$A = 16$$

$$B = 16 + 12 = 28$$

$$C = 16 + 12 + 10 = 38$$

$$D = 16 + 12 + 10 + 8 = 46$$

$$E = 16 + 12 + 10 + 8 + 7 = 53$$

$$F = 16 + 12 + 10 + 8 + 7 + 4 = 57$$

$$G = 16 + 12 + 10 + 8 + 7 + 4 + 2 = 59$$

$$H = 16 + 12 + 10 + 8 + 7 + 4 + 2 + 1 = 60$$

Average processing time = $357/8 = 44.6$, which is much more than the previous time.

3.3 PRIORITY SEQUENCING RULES

The following priority sequencing rules are generally followed in production/service system:-

1. **First Come First Served (FCFS).** As explained earlier, it is followed to avoid any heart burns and avoidable controversies.
2. **Earliest Due Date (EDD).** In this rule, top priority is allotted to the waiting job which has the earliest due/delivery date. In this case the order of arrival of the job and processing time it takes is ignored.
3. **Least Slack Rule(LS).** It gives top priority to the waiting job whose slack time is the least. Slack time is the difference between the length of time remaining until the job is due and the length of its operation time
4. **Average Number of Jobs in the system.** It is defined as the average number of jobs remaining in the system (waiting or being processed) from the beginning of sequence through the time when the last job is finished.
5. **Average Job Lateness.** Jobs lateness is defined as the difference between the actual completion time of the job and its due date. Average job lateness is sum of lateness of all jobs divided by the number of jobs in the system. This is also called Average Job Tardiness.
6. **Average Earliness of Jobs.** If a job is completed before its due date, the lateness value is negative and the magnitude is referred as earliness of job. Mean earliness of the job is the sum of earliness of all jobs divided by the number of jobs in the system.
7. **Number of Tardy Jobs.** It is the number of jobs which are completed after the due date.

3.4 SEQUENCING n JOBS THROUGH TWO MACHINES

The sequencing algorithm for this case was developed by Johnson and is called Johnson's Algorithm. In this situation n jobs must be processed through machines M_1 and M_2 . The processing time of all the n jobs $c: M_1$ and M_2 is known and it is required to find the sequence, which minimizes the time to complete all the jobs.

Johnson's algorithm is based on the following assumptions:-

- (i) There are only two machines and the processing of all the jobs is done on both the machines in the same order i.e first on M_1 and then on M_2
- (ii) All jobs arrive at the same time (static arrival pattern) have no priority for job completion. Johnson's Algorithm involves following steps:-

1. List operation time for each job on machine M_1 and M_2 .
2. Select the shortest operation or processing time in the above list.
3. If minimum processing time is on M_1 , place the corresponding job first in the sequence. If it is on M_2 , place the corresponding job last in the sequence. In case of tie in shortest processing time, it can be broken arbitrarily.
4. Eliminate the jobs which have already been sequenced as result of step 3
5. Repeat step 2 and 3 until all the jobs are sequenced

Example 3.

Six jobs are to be sequenced which require processing on two machines M_1 and M_2 . The processing time in minutes for each of the six jobs on machines M_1 and M_2 is given below. All the jobs have to be processed in sequence M_1 , M_2 . Determine the optimum sequence for processing the jobs so that the total time of all the jobs in minimum. Use Johnson's Algorithm

Jobs		1	2	3	4	5	6
Processing Time	Machine M_1	30	30	60	20	35	45
	Machine M_2	45	15	40	25	30	70

Solution.

Step I. Operation time or processing time for each jobs on M_1 and M_2 is provided

in the question.

Step II. The shortest processing time is 15 for job 2 on M_2 .

Step III. As the minimum processing time is on M_2 , job 2 has to be kept last as follows.

					2
--	--	--	--	--	---

Step IV. We ignore job 2 and find out the shortest processing time of rest of jobs. Now the least processing time is 20 minutes on machine M_1 for 4. Since it is on M_1 , it is to be placed first as follows

4					2
---	--	--	--	--	---

The next minimum processing time is 30 minutes for job 5 on M_2 and Job 1 on M_1 . So job 5 will be placed at the end. Job 1 will be sequenced earlier as shown below.

4	1			5	2
---	---	--	--	---	---

The next minimum processing time 40 minutes for Job 3 on M_2 , Hence it is sequenced as follows.

4	1		3	5	2
---	---	--	---	---	---

Job 6 has to be sequenced in gap or vacant space. The complete sequencing of the jobs is as follows

4	1	6	3	5	2
---	---	---	---	---	---

The minimum time for six jobs on machine M_1 and M_2 can be shown with the help of a Gantt chart as shown below.

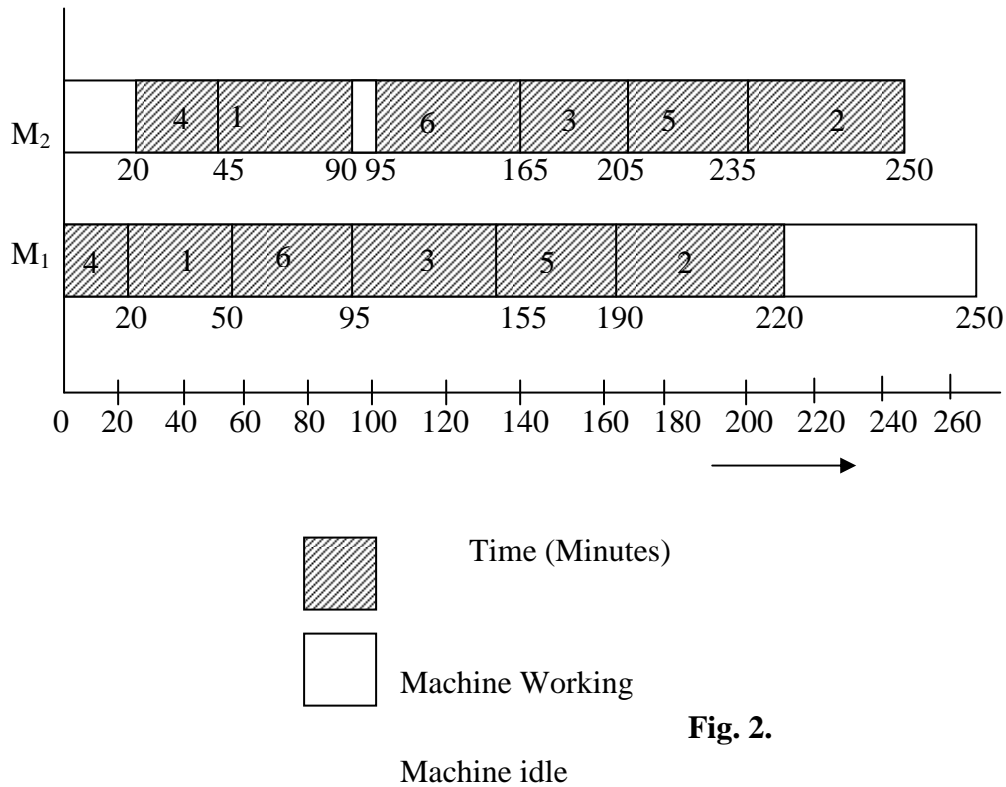

Fig. 2.

The above figure show idle time for M₁ (30 minutes) after the last job (2) has been processed. Idle time for M₂ is 20 minutes before job 4 is started and 5 minutes before processing 6 and finishing job 1. The percentage utilization of M₁ = $250 - 30/250 = 88\%$ M₂ = $250 - 25/250 = 90\%$

Example 4.

A book-binder has one printing press, one binding machine and manuscript of seven different books. The time required fro performing printing and binding operations fro different books are shown below:

Book	Printing Time (days)	Binding Time (days)
1	20	25
2	90	60
3	80	75
4	20	30
5	120	90
6	15	35
7	65	50

Decide the optimum sequence of processing of books in order to minimize total time

Sol. Step 1. Minimum time is 15 days on printing press (M_1) for job 6 so it will be sequenced earlier as shown

6						
---	--	--	--	--	--	--

Step II. Now book 1 and 4 have the least time of 20 days on printing press (M_1) so these two books will be sequenced as

6	1	4				
---	---	---	--	--	--	--

Step III. After eliminating job 6, 1 and 4 least time is for job 7 on binding machine (M_2) so it will be placed last in the sequence.

6	1	4				7
---	---	---	--	--	--	---

Step IV. Now book 2 has least time of 60 on M_2 , hence it will be placed at the end.

6	1	4			2	7
---	---	---	--	--	---	---

Step V. Book 3 has the least time of 75 days on M_2 so it will be placed as below.

6	1	4		3	2	7
---	---	---	--	---	---	---

Step VI. Jobs 5 will be placed in the vacant place

6	1	4	5	3	2	7
---	---	---	---	---	---	---

Step VII. Total processing time can be calculated as follows

Optimum sequence of jobs (books)	Printing		Binding		Idle time for Binding
	In	Out	In	Out	
6	0	15	15	50	15
1	15	35	50	75	-
4	35	55	75	105	-
5	55	175	175	265	70
3	175	255	265	340	-
2	255	345	345	405	5
7	345	410	410	460	5

Total idle time

Printing = $(460 - 410) = 50$ days as the printing last job (7) is finished on 410 days but binding finishes only after 460 days, so printing machine is idle for 50 days.

Binding = $15 + 70 + 5 + 5 = 95$ days

Example 5. A manufacturing company has 5 different jobs on two machines M_1 and M_2 . The processing time for each of the jobs on M_1 and M_2 is given below. Decide the optimal sequence of processing of the jobs in order to minimize total time.

Jon. No	Processing Time	
	M_1	M_2

1	8	6
2	12	7
3	5	11
4	3	9
5	6	14

Sol. The shortest processing time is 3 on M_1 for job 4 so it will be sequenced as follows

4				
---	--	--	--	--

Next is job 3 with time 5 and M_1 , hence job 3 will be sequenced as

4	3			
---	---	--	--	--

Next minimum time is for jobs 1 on M_2 , this will be sequenced last

4	3			1
---	---	--	--	---

After eliminating jobs 4,3 and 1 the next with minimum time is job 5 on M_1 so it will be placed as

4	3	5		1
---	---	---	--	---

Now job 2 will be sequenced in the vacant space.

4	3	5	2	1
---	---	---	---	---

3.5 n- JOBS 3 MACHINE CASE

Johnson's algorithm which we have just applied can be extended and made use of n jobs 3 machine case, if the following conditions hold good:-

(a) Maximum processing time for a job on machine M_1 is greater than or equal to maximum processing time for the same job.

or

(b) Minimum processing time for a job on machine M_3 is greater than or equal to maximum processing time for a job on machine M_2

The following assumptions are made:-

(a) Every job is processed on all the three machines M_1 , M_2 and M_3 in the same order i.e. the job is first processed on M_1 then on M_2 and then on M_3 .

(b) The passing of jobs is not permitted

(c) Process time for each job on the machine M_1 , M_2 and M_3 are known.

In this procedure two dummy machines M_1' and M_2' are assumed in such a manner that the processing time of jobs on these machines can be calculated as

Processing time of jobs on $M_1' = \text{Processing time } (M_1 + M_2)$

Processing time of job on $M_2' = \text{Processing time } (M_2 + M_3)$

After this Johnson's algorithm is applied on M_1' and M_2' to find out the optimal sequencing of jobs.

Example 6. In a manufacturing process three operations have to be performed on machines M_1 , M_2 and M_3 in order M_1 , M_2 and M_3 . Find out the optimum sequencing when the processing time for four jobs on three machines is as follows:-

Job	M_1	M_2	M_3
1	3	8	13
2	12	6	14
3	5	4	9
4	2	6	12

Sol. Step 1. As the minimum processing time for job 2 on $M_1 >$ maximum processing time for job 2 on M_2 . Johnson's algorithm can be applied to this problem.

Step II. Let us combine the processing time of M_1 & M_2 and M_3 to form two dummy machines M_1' and M_2' . This shown in the matrix below.

Job	M_1	M_2
1	11(3 + 8)	21(3 + 8)
2	18 (12+6)	20 (6+14)
3	9 (5 + 4)	13 (4 + 9)
4	8(2 + 6)	18(6 + 12)

Ste III. Apply Johnson's algorithm. Minimum time of 8 occurs for job 4 on M_1' hence it is sequenced first.

4	3	1	
---	---	---	--

The next minimum time is for job 3 on M_1' so it is sequenced next to job 4. Next is job 1 and so on. So the optimal sequencing is

4	3	1	2
---	---	---	---

Example 7.

Six jobs have to be processed on machines M_1 , M_2 and M_3 in order M_1 , M_2 and M_3 . Time taken by each job on these machines is given below. Determine the sequence so as to minimize the processing time.

Job	M_1	M_2	M_3
-----	-------	-------	-------

1	12	7	3
2	8	10	4
3	7	9	2
4	11	6	5
5	10	10	3
6	5	5	4

Solution.

Step I. As the minimum processing time for jobs 1 and 4 on M_1 is greater than on M_2 , Johnson's algorithm can be applied.

Step II. Combine the processing time of M_1 , M_2 and M_3 and develop new matrix for machine M_1' and M_2' as follows.

Job	M_1'	M_2'
1	19(12+7)	10(7+3)
2	18(8+10)	14(10+4)
3	16(7+9)	11(9+2)
4	17(11+6)	11(6+5)
5	20(10+10)	13(10+3)
6	10(5+5)	9(5+4)

Step III. Use Johnson's algorithm and sequence the jobs Minimum processing time of 9 occurs for job 6 on M_2' so it will be sequenced the last

					6
--	--	--	--	--	---

Next minimum processing time of 10 occurs for job 1 on M_2' so job 1 will sequenced next to job 6

				1	6
--	--	--	--	---	---

Next minimum processing time is 11 for jobs 3 and 4 on machine M_2' so these will be sequenced as shown.

		3	4	1	6
--	--	---	---	---	---

Next minimum is 13 for jobs 5 on machine M_2' and after that job 2 has minimum processing time of 14 on M_2' , hence the sequencing is as follows.

2	5	3	4	1	6
---	---	---	---	---	---

3.4 'n' Jobs 'm' Machine Case

Let there be 'n' jobs 1, 2, 3, N and 'm' machine M_1, M_2, M_3, \dots, m . The order of processing is M_1, M_2, M_3, \dots, m and no passing is permitted. The processing time for the machine is shown below:

Job	M ₁	M ₂	M ₃	m
1	a ₁	b ₁	c ₁	M ₁
2	a ₂	b ₂	c ₂	M ₂
3	a ₃	b ₃	c ₃	M ₃
:	:	:	:	:
:	:	:	:	:
n	a _n	b _n	c _n	M _n

If the following conditions are used, we can replace 'm' machine by an equivalent of two machines problem.

(a) $\text{Min } a_i \geq \max \text{ of } M_2, M_3 \dots (m - 1)$

(b) $\text{Min } m \geq \max M_2, M_3 \dots (m - 1)$

When $M_1' = a + b_i + c_i + \dots + (m - 1)$

$M_2' = b_i + c_i + \dots + (m - 1)_i + m_i$

Example 8.

Determine the optimal sequence of performing 5 jobs on 4 machines. The machines are used in the order M₁, M₂, M₃ and M₄ and the processing time is given below:

Job	M ₁	M ₂	M ₃	M ₄
1	8	3	4	7
2	9	2	6	5
3	10	6	6	8
4:	12	4	1	9
5	7	5	2	3

Solution.

Step I. Let us find out if any of the conditions stipulated is satisfied or not.

Condition 1. $\text{Min } a_i \geq \max \text{ of } M_2 \text{ and } M_3$

$\text{Min } a_i = 7$

$\text{Min } b_i = 6$

$\text{Min } c_i = 6$

Hence the condition is satisfied.

Job	$M_1' = a_i + b_i + c_i$	$M_2' = b_i + c_i + d_i$
1	15(8 + 3 + 4)	14 (3 + 4 + 7)
2	17(9 + 2 + 6)	13 (2 + 6 + 5)

3	$22(10 + 6 + 6)$	$20(6 + 6 + 8)$
4	$17(12 + 4 + 1)$	$14(4 + 1 + 9)$
5	$14(7 + 5 + 2)$	$10(5 + 2 + 3)$

Step III. Now solve 5 jobs 2 machine problem

Minimum time of processing is for job 5 on machine M_2' so it will be sequenced last

				5
--	--	--	--	---

Next minimum time is 13 for job 2 on machine M_2' so it will be sequenced as shown

			2	5
--	--	--	---	---

Next minimum time is for job 1 and 4 on machine M_2' so it will be sequenced as shown

	1	4	2	5
--	---	---	---	---

Next minimum time is 20 for job 3 on machine M_2' .

3	1	4	2	5
---	---	---	---	---

Example 9.

Solve the following sequencing problem when passing off is not allowed

Job	Machine Processing time in hours			
	A	B	C	D
I	15	5	4	15
II	12	2	10	12
III	16	3	5	16
IV	17	3	4	17

Solution.

Let us find out if one of the conditions is satisfied

Step I. $\min a_i \geq \max b_i$ and c_i

Or $\min d_i \geq \max b_i$ and c_i

Here both the conditions are satisfied.

Step II. The problem can be converted into 4 jobs 2 machines problem by introducing two fictitious machine M_1' and M_2' as follows.

Job	M_1'	M_2'
-----	--------	--------

I	24 (15 + 5 + 4)	24 (5 + 4 + 15)
II	24 (12 + 2 + 10)	24 (2 + 10 + 12)
III	24 (16 + 3 + 5)	24 (3 + 5 + 16)
IV	24 (17 + 3 + 4)	24 (3 + 4 + 17)

When $M_1' = a_i + b_i + c_i$

$M_2' = b_i + c_i + d_i$

Since all the processing times are equal, the jobs can be sequenced in any manner and all sequences are optimal and will give the same minimum time. Total time can be worked out from the table below:

Job	Machine A		Machine B		Machine C		Machine D	
	In	Out	In	Out	In	Out	In	Out
I	0	15	15	20	20	24	24	39
II	15	27	27	29	29	39	39	51
III	27	43	43	46	46	51	51	67
IV	43	60	60	63	63	67	67	84

Total time = 84 hours

Idle time Machine A = 84 – 60 = 24 hours

Machine B = 15 + 7 + 14 + 15 + (84 – 63)

= 15 + 7 + 14 + 15 + 21 = 71 hours

Machine C = 20 + 5 + 7 + 12 + (84 – 67) = 61 hours

Machine D = 24 hours

Example 10.

Four Jobs 1, 2, 3, and 4 are to be processed on each of the five machines M_1, M_2, M_3, M_4 and M_5 in the order M_1, M_2, M_3, M_4, M_5 . Determine total minimum elapsed time if no passing off is allowed. Also find out the idle time of each of the machines. Processing times are given in the matrix below.

Job	Machines				
	M_1	M_2	M_3	M_4	M_5
1	8	4	6	3	9
2	7	6	4	5	10
3	6	5	3	2	8
4	9	2	1	4	6

Solution.

Step I. Find out if the condition minimum $e_i \geq \max b_i, c_i$ and d_i is satisfied.

Job	Machines
-----	----------

	M ₁	M ₂	M ₃	M ₄	M ₅
1	8	4	6	3	9
2	7	6	4	5	10
3	6	5	3	2	8
4	9	2	1	4	6
	Min 6	Max 6	Max 6	Max 5	Min 6

This condition is satisfied hence we can convert the problem into four jobs and two fictitious machines M₁' and M₂'

$$M_1' = a_i + b_i + c_i + d_i, \quad M_2' = b_i + c_i + d_i + e_i$$

Step II.

Job	M ₁ '	M ₂ '
1	21(8 + 4 + 6 + 3)	22 (4 + 6 + 3 + 9)
2	22 (7 + 6 + 4 + 5)	25 (6 + 4 + 5 + 10)
3	16 (6 + 5 + 3 + 2)	18 (5 + 3 + 2 + 8)
4	16 (9 + 2 + 1 + 4)	13 (2 + 1 + 4 + 6)

Step III. The optimal sequence can be determined as minimum of processing time of 13 occurs on M₂' for job 4 it will be processed last. Next minimum time is for job 3 on machine M₁' so it will be processed earliest. Next shortest time is for machine 1 on M₁', so it will be sequenced next to job 3 and so on.

3	1	2	4
---	---	---	---

Job	M ₁		M ₂		M ₃		M ₄		M ₅	
	In	Out	In	Out	In	Out	In	Out	In	Out
1	0	8	8	12	12	18	18	21	21	30
2	8	15	15	21	21	25	25	30	30	40
3	15	21	21	26	26	29	29	32	40	48
4	21	30	30	32	30	31	32	36	48	54

Hence total minimum elapsed time is 51

Idle time for machines M₁ = 24 hours

$$M_2 = 3 + 4 + 22 = 29$$

$$M_3 = 3 + 1 + 1 + 23 = 28$$

$$M_4 = 4 + 18 = 22$$

Two Jobs 'm' Machine case

- Two axis to represent job 1 and 2 are drawn at right angles to each other. Same scale is used to X and Y axis. S-axis represents the processing time and sequence of job 1 and Y axis represents the processing time and sequence of job 2. The processing time on machines are laid out in the technological order of the problem.

2. The area which represents processing times of jobs 1 and 2 and is common to both the jobs is shaded. As processing of both the jobs on same machine is not feasible, the shaded area represents the unfeasible region in the graph.
3. The processing of both the job 1 and 2 are represented by a continued path which consists of horizontal, vertical and 45 degree diagonal region. The path starts at the lower left corner and stops at upper right corner and the shaded area is avoided. The path is not allowed to pass through shaded area which as brought out in step II represent both the jobs being processed simultaneously on the same machine.
Any vertical movement represents that job 2 is in progress and job 1 is waiting to be processed. Horizontal movement along the path indicates that 1 is in progress and job 2 is idle waiting to be processed. The diagonal movement of the path indicates that both the jobs are being processed on different machines simultaneously.
4. A feasible path maximizes the diagonal movement minimizes the total processing time.
5. Minimum elapsed time for any job = processing time of the job + idle time of the same job.

Example 11.

The operation time of two jobs 1 and 2 on 5 machines $M_1, M_2, M_3, M_4,$ and M_5 . is given in the following table. Find out the optimum sequence in which the jobs should be processed so that the total time used is minimum. The technological order of use of machine for job 1 is $M_1, M_2, M_3, M_4,$ and M_5 . for job 2 is $M_3, M_1, M_4, M_5,$ and M_2 .

Time Hours

Job	M_1	M_2	M_3	M_4	M_5
1	1	2	3	5	1
Job	M_3	M_1	M_4	M_5	M_2
2	3	4	2	1	5

Job 1 proceeds job 2 machine M_1 , job 1 proceeds job 2 on machine M_2 , job 2 precedes job 1 on machine M_3 , job 1 precedes job 2 on M_4 and job 2 precedes job 1 on M_5 .

The minimum processing time for job 1 and 2, Total processing time for job 1 + idle time for job 1 = $12 + 3 = 15$ hours.

Total processing time for job 2 + idle time for job 2 = $15 + 0 = 15$ hours.

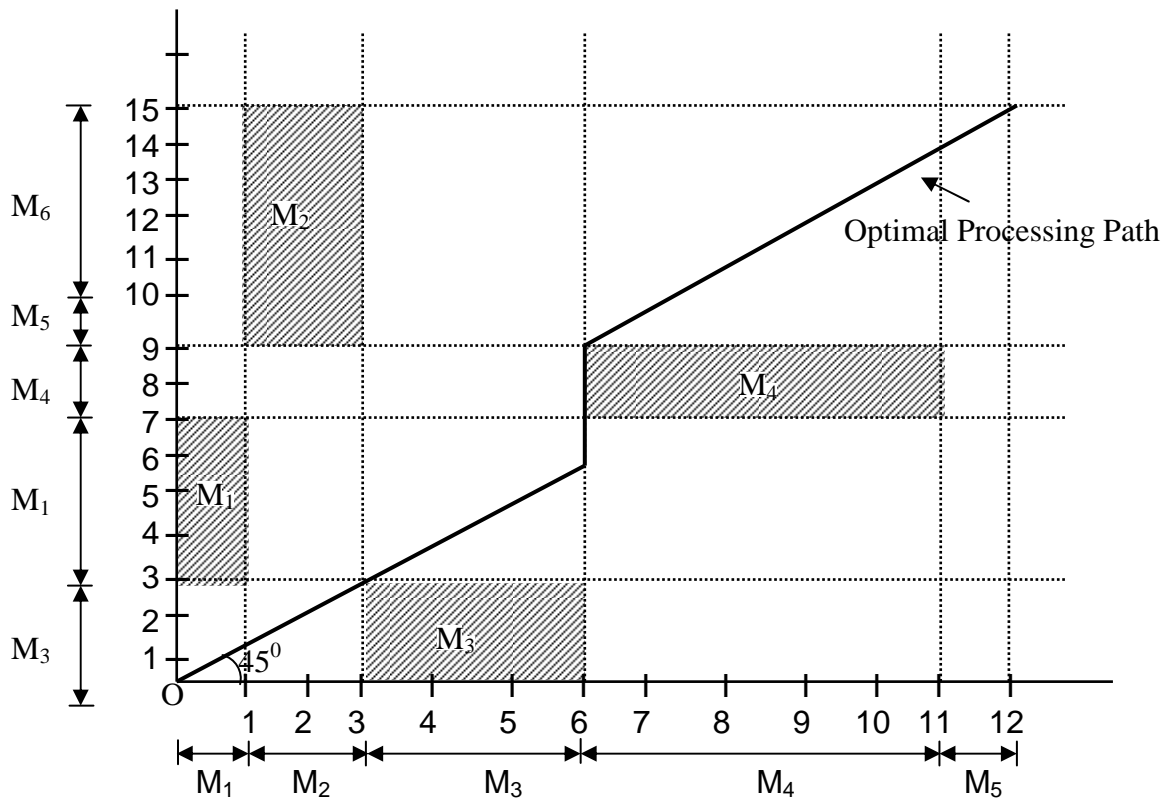

Fig.3.

Example 12. Two parts A and B for a product need processing for their operations through six machines at stations $S_1, S_2, S_3, S_4, S_5,$ and S_6 . The technological order of these parts and the manufacturing time on the machines are as given below:

Par A	Technological Order	S_3	S_1	S_5	S_6	S_4	S_2
	Time (hours)	2	3	4	5	6	1
Part B	Technological Order	S_2	S_1	S_5	S_6	S_3	S_4
	Time (hours)	3	2	5	3	2	3

Determine the optimal sequencing order to minimize the total processing time for part A and B.

Sol. Let us construct the two dimensional graph let X-axis represent Job A and Y-axis represent Job B.

Total elapsed time = 23

Par A = 21 + 2 (Idle time) = 23

Part = 18 + (2 + 2 + 1) idle time = 23

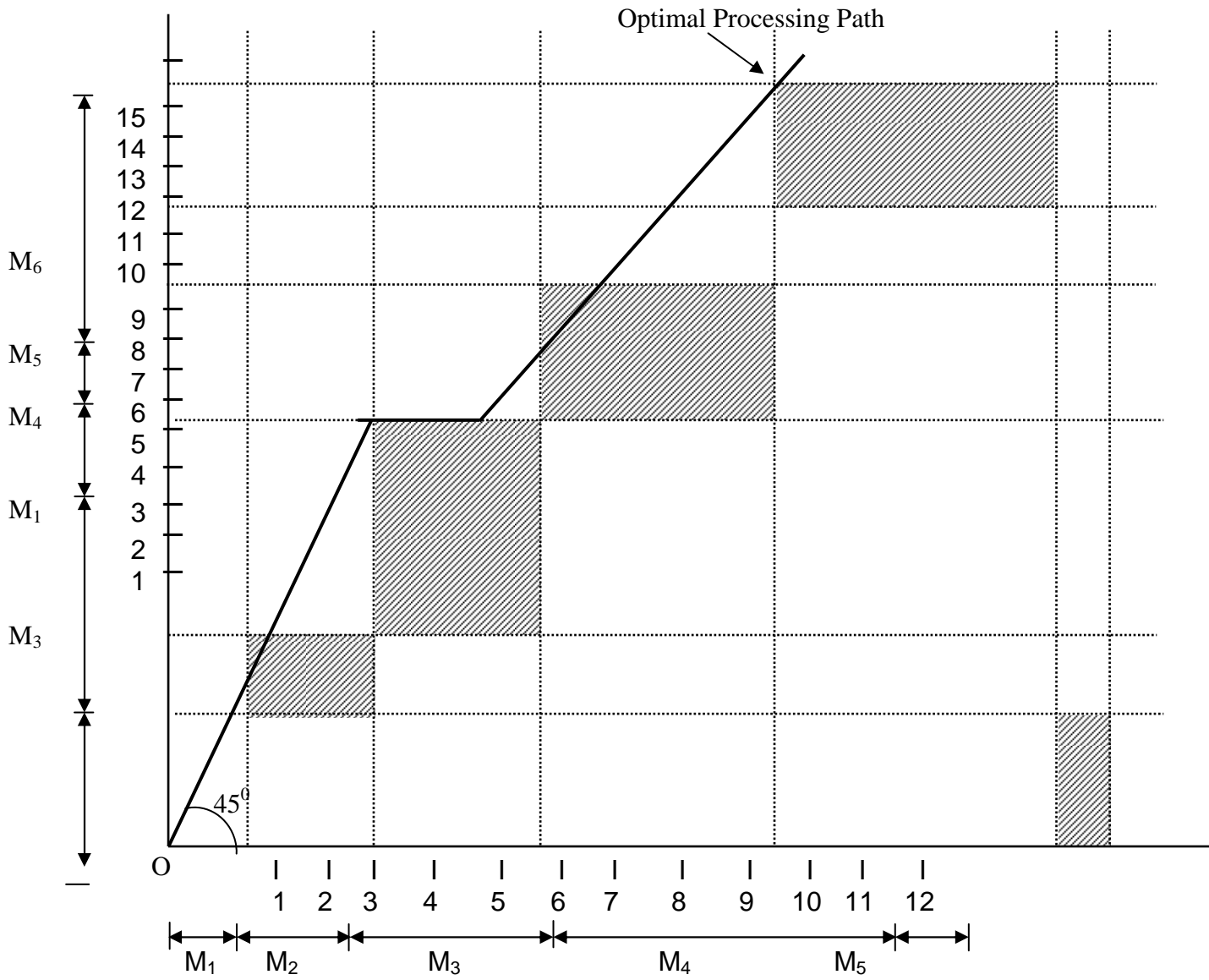

Fig. 4.

Example13. There are two jobs to be performed on 5 machines. The following data is available. Find out the minimum total time sequence.

Job 1 sequence Time (Hours)	M ₁	M ₂	M ₃	M ₄	M ₅
	2	3	4	6	2
Job 2 sequence Time (Hours)	M ₃	M ₁	M ₄	M ₅	M ₂
	4	5	3	2	6

Solution.

Let draw X-axis representing job 1 and Y-axis representing job 2. Horizontal lines represent job 1 being processed when job 2 is waiting to be processed. Horizontal line indicates job 2 is being processed and job 1 is idle.

Idle time for job 1 = 3

Idle time for job 2 = 0

Total elapsed time = 20 hours

4.0 Conclusion

As in summary

5.0 Summary

1. Scheduling, which occurs in every organization, refers to establishing the timing of the use of equipment, facilities and human activities in an organisation and so it deal with the timing of operations.
2. Scheduling technique depends on the volume of system output, the nature of operation and the overall complexity of jobs.
3. The complexity of operation varies under two situations, namely flow shop system and job shop system.
4. Flow shop is a high volume system while job shop is a low volume system.

5. Loading refers to assignment of jobs to work centres.
6. The two main methods that can be used to assign job to work centres are use of ganti chart and assignment method.
7. Job sequencing refers to the order in which job should be processed at each work station.
8. Priority rules enables us to select the order in which job should be done
9. The main objective of priority rules is to minimize completion time, number of job in the system, and job lateness, while maximizing facility utilization.
10. IN FCFS, which means first come served, job is processed in the order of arrivals at work centres.
11. In short processing time (SPT) jobs are processed based on the length of the processing time with the job with the least processing time being done first.
12. In Earliest Due date (EDD) the job with the earliest due date is processed first.
13. In longest processing time (LPT) the job with longest processing time are started first.
14. Johnson's rule is used to sequence two or more jobs in two different work centers in the same order.

6.0 Tutor Marked Assignment

There are 12 examples solved in this unit. You are advised to attempt some of this examples as exercises with honesty of purpose.

7.0 References/Further Readings

1. Operations Research. By Prem Kumar Gupta and D.S. Hira
2. Operations Research. (Problem Solvers) By Research and Education Association.
27. Statistics and Operations Research. By Debashis Dutta
28. Operations Research By). O.T. Arowolo and G.O. Lawal

UNIT 4 **Waiting Line (Queuing) Theory**

CONTENTS

22.0	Introduction
23.0	Objective
24.0	Main Content
24.1	Objectives and models of the theory
24.2	Benefits and limitations of queuing model
24.3	Important term and notations used
24.4	Single-channel queuing model
24.5	Mutil-channel queuing model
24.6	Review and Discussion Questions
25.0	Conclusion
26.0	Summary
27.0	Tutor Marked Assignment
28.0	References/Further Readings

1.0 INTRODUCTION

Queues of customers arriving for service of one kind or another arise in many different fields of activity. Business of all types, government, industry, telephone exchanges, and airports, large and small all have queuing problems. Many of these congestion situations could benefit from OR analysis, which employs to this *purpose* a variety of queuing models, referred to as queuing systems or simply queues.

A queuing system involves a number of servers (or serving facilities) which we will also call *service channels* (in deference to the source field of the theory telephone communication system). The serving channels can be communications links, work stations, check-out counters, retailers, elevators, buses, to mention but a few. According to the number of servers, queuing systems can be of single and multi-channel type.

2.0 OBJECTIVES

1. Appreciate situations in which queuing problems are generated
2. Learning to set objectives for the operation of queuing
3. Understand standard queuing language and symbols.
4. Understanding operating characteristics of queuing.

5. Solving queuing problems in single-channel and multiple-channel situations
6. Understand the advantages and limitations of queuing systems.

3.0 MAIN CONTENT

3.1 OBJECTIVE AND MODELS OF THE THEORY

Customers arriving at a queuing system at random intervals of time are serviced generally for random times too. When a service is completed, the customer leaves the servicing facility rendering it empty and ready and get next arrival. The random nature of arrival and service times may be a cause of congestion at the input to the system at some periods when the incoming customers either queue up for service or leave the system unserved; in other periods the system might not be completely busy because of the lack of customers, or even be idle altogether.

decision variables, since they may be either of these characteristics, for example, the number of channels, their capacity, service mechanism, etc. the most important part of a study is model establishment (primal problems) while its optimization (inverse problem) is indeed depending on which parameters are selected to work with or to change. We are not going to consider optimization of queuing models in this text with the exception made only for the simplest queuing situation.

The mathematical analysis of a queuing system simplifies considerably when the process concerned is Markovian. Markov process may be defined as, 'A random process is referred to as Markov, if for any moment of time, its probability characteristics in the future 'depend only on its state at time and are independent of when and how this state was acquired. 'As we already know a sufficient condition for this is that all the process changing system's states (arrival intervals, service intervals) are Poisson. If this property does not hold, the mathematical description of the process complicates substantially and acquires an explicit analytical form only in seldom cases. However, the simplest mathematics of Markov queues may prove of value for approximate handling even of those queuing problems whose arrivals are distributed not in a Poisson process. In many situations a reasonable decision on queuing system organization suffices with an approximate models.

All of the queuing systems have certain basic characteristics. They are (a) *input process (arrival pattern)* which may be specified by the source of arrivals, type of arrivals and the inter-arrival time, (b) *service mechanism*, which is the duration and mode of service and may be characterized by the service-time distribution, capacity of the system, and service availability, and (c) *queue discipline* which includes all other factors regarding the rules of conduct of the queue.

We start illustrating the classification breakdown with a *loss and delay system*. In a purely loss system, customers arriving when all the servers are busy are denied service and are lost to the system. Examples of the loss system may be met in telephone : an

incoming call arrived at an instant when all the channels are busy cannot be placed and leaves the exchange unserved. In a *delay system* an arrival incoming when all the channels are busy does not leave the system but joins the queue and waits (if there is enough waiting room) until a server is free. These latter situations more often occur in applications and are of great importance, which can be readily inferred from the name of the theory.

According to the type of the source-supplying customers to the system, the models are divided into those of a finite population size, when the customers are only few, and the infinite-population systems. The length of the queue is subject to further limitation imposed by allowable waiting time or handling of impatient customer which are liable to the system.

The queue discipline, that is the rule followed by the server in taking the customers in service, may be according to such self-explanatory principles as “first-come, first-served”, “last-come, first-served” or chain “random selection for serve”. In some situation priority discipline need be introduced to allow for realistic queues with high priority arrival. To illustrate in extreme cases the server may stop the service of a customer of lower priority in order to deal with a customer of high priority; this is called pre-emptive priority. For example a gantry crane working on a container ship may stop the unloading halfway and shift to another load to unload perishable goods of a later arrived ship. The situation when a service of a low priority customer started prior to the arrival of a high priority customer is completed and the high priority customer receive only a better position in the queue is called *non – pre-emptive* priority. This situation can be exemplified by an airplane which enters a queue of a few other aircraft circling around an air port and ask a permission for an emergency landing ; the ground control issues the permission on the condition that it lands next to the air plane being on a run way at the moment.

Turning over to the service mechanism, we may find systems whose servicing channels are placed *in parallel* or *in series*. When in series, a customer leaving a previous server enters a queue for the next channel in the sequence. For example, a work piece being through the operation with one robot on a conveyor is stacked to wait when the next robot in the process is free to handle it. These operation stages of a series-channel queuing system are called *phases*. The arrival pattern may and may not correlate with the other aspects of the system. Accordingly, the system can be loosely divided into “Open” and “Close”. In an open system, the distribution of arrivals does not depend on the status of the system say on how many channel are busy. To contrast, in a close system, it does, for example, if a single operator tends a few similar machines each of which has a chance of stopping i.e. arriving for serve, at random, then the arrival rate of stopping depends on how many mechanics have been already adjusted and put on the yet served.

An optimization of a queuing system may be attempted from either of two stand point, the first in favour of queuers or owners of the queue, the second to favour the

“queuers”, i.e., the customers, the first stand makes a point of the efficiency of the system and would tend to load all the channels as high as possible, i.e., to cut down idea time. The customers on the contrary would like to cut down waiting time in a queue. Therefore, any optimization of congestion necessitate a “system approach” with the intrinsic complex evaluation and assessment of all consequences for each possible decision. The need for optimality over conflicting requirement may be illustrated with the view point of the customer wishing to increase the number of channels, which, however, would increase the total servicing cost. The development of a reasonable model may help solving the optimization problem by choosing the number of channels which account for all pros and cons. This is the reason why we do not suggest a single measure of effectiveness for all queuing problems, formulating them instead as multiple objective problems.

All the mentioned forms of queues (and many others for which we give no room here) are being studied by queuing theory where there is a huge literature. The discussion, though, almost nowhere tunes an appropriate methodological level: the derivations are often too complicated, and deduced not in the very best way

3.2 BENEFITS AND LIMITATIONS OF QUEUING THEORY

Queuing theory has been used for many real life applications to a great advantage. it is no possible to accurately determine the arrival and departure of customers when the number and types of facilities as also the requirements of the customers are not known. Queuing theory techniques, in particular, can help us to determine suitable number and type of service facilities to be provided to different types of customers.

Queuing theory techniques can be applied to problems such as:-

- (a) Planning scheduling and sequencing of parts and components to assembly line in a mass production system
- (b) Schedule of workstations and machines performing different operations in mass production
- (c) Scheduling and dispatch of war material of special nature based on operational needs
- (d) Scheduling of service facilities in a repair and maintenance workshop
- (e) Scheduling of overhaul of used engines and other assemblies of aircrafts, missile system, transport fleet etc
- (f) Scheduling of limited transport fleet to a large number of users
- (g) Schedule of landing and take off from airports with heavy duty of air traffic and limited facilities
- (h) Decision of replacement of plant, machinery, special maintenance tools and other equipment based on different criteria Special benefit which this technique enjoys in solving problems such as above are

- (i) Queuing theory attempts to solve problems based on a scientific understanding of the problems and solving them in optimal manner so that facilities are fully utilized and waiting time is reduced to minimum possible
- (j) Waiting time (or queuing) theory models can recommend arrival of customers to be serviced, setting up of workstations, requirement of manpower etc. based on probability theory

3.2.1 LIMITATION OF QUEUING THEORY

Though queuing theory provides us a scientific method of understanding the queues and solving such problems, the theory has certain limitations which must be understood while using the technique, some of these are:

- (a) Mathematical distributions, which we assume while solving queuing theory problems, are only a close approximation of the behaviour of customers, time between their arrival and service time required by each customer.
- (b) Most of the real life queuing problems are complex situation and very difficult to use the queuing theory technique, even then uncertainty will remain.
- (c) Many situations in industry and service are multi-channel queuing problems. When a customer has been attended to and the service provided, it may still have to get some other service from another service and may have to fall in queue once again. Here the departure of one channel queue becomes the arrival of the channel queue. In such situations, the problem becomes still more difficult to analyse.
- (d) Queuing model may not be the ideal method to solve certain very difficult and complex problems and one may have to resort to other techniques like Monte –Carlo simulation method.

3.3 IMPORTANT TERMS USED IN QUEUING THEORY

1. **Arrival Pattern.** It is the pattern of the arrival of a customer to be serviced. The pattern may be regular or at random. Regular interval arrival patterns are rare, in most of the cases of the customers cannot be predicted. Remainder pattern of arrival of customers follows Poisson's distribution.
2. **Poisson's Distribution.** It is discrete probability distribution which is used to determine the number of customers in a particular time. It involves allotting probability of occurrence of the arrival of a customer. Greek letter λ (lamda) is used to denote mean arrival rate. A special feature of the Poisson's distribution is that its mean is equal to the variance. It can be represented with the notation as explained below:

$P(n)$ = Probability of n arrivals (customers)

λ = Mean arrival rate

e = Constant = 2.71828

$$P(n) = \frac{e^{-\lambda} (\lambda)^n}{n!} \text{ where } n = 0, 1, 2, \dots$$

Notation N or $n!$ is called the factorial and it mean that

$$N \text{ or } n! = n(n - 1) (n - 2) (n - 3) \dots \dots \dots 2, 1$$

Poisson's distribution tables for different values of n and λ are available and can be used for solving problems where Poisson's distribution is used. However, it has certain limitations because of which its used is restricted. It assumes that arrivals are random and independent of all other variables or other variables or parameters. Such can never be the case.

3. **Exponential Distribution.** This is based on the probability of completion of a service and is the most commonly used distribution in queuing theory. In queuing theory, our effort is to minimize the total cost of queue and it includes cost of waiting and cost of providing service. A queue model is prepared by taking different variables into consideration. In this distribution system, no maximization or minimization is attempted. Queue models with different alternatives are considered and the most suitable for a particular is attempted. Queue models with different alternatives are considered and the most suitable for a particular situation is selected.
4. **Service Pattern.** We have seen that arrival pattern is random and Poisson distribution can be used for use in queue model. Service pattern are assumed to be exponential for purpose of avoiding complex mathematical problem.
5. **Channels.** A service system has a number of facilities positioned in a suitable manner. These could be
 - (a) **Single Channel – Single Phase System.** This is very simple system where all the customers wait in a single line in front of a single service facilities and depart after service is provided. In a shop if there is only one person to attend to a customer is an example of the system

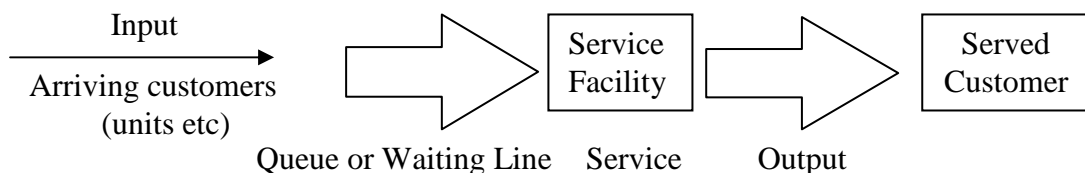

Fig. 9.1

- (b) **Service in series.** Here the input gets services at one service station and then moves to second and or third and so on before going out. This is the case

when a raw material input has to undergo a number of operations like cutting, turning drilling etc.

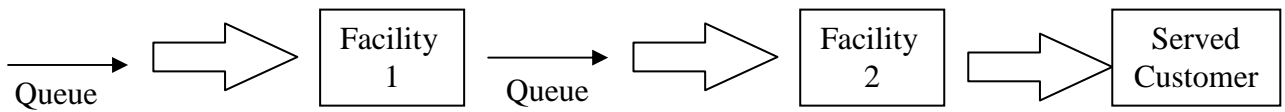

Fig. 9.2

3.3.1 MULTI PARALLEL FACILITY WITH A SINGLE QUEUE

Here the service can be provided at a number of points to one queue. This happens when in a grocery store, there are 3 persons servicing the same queue or a service station having more than one facility of washing cars.

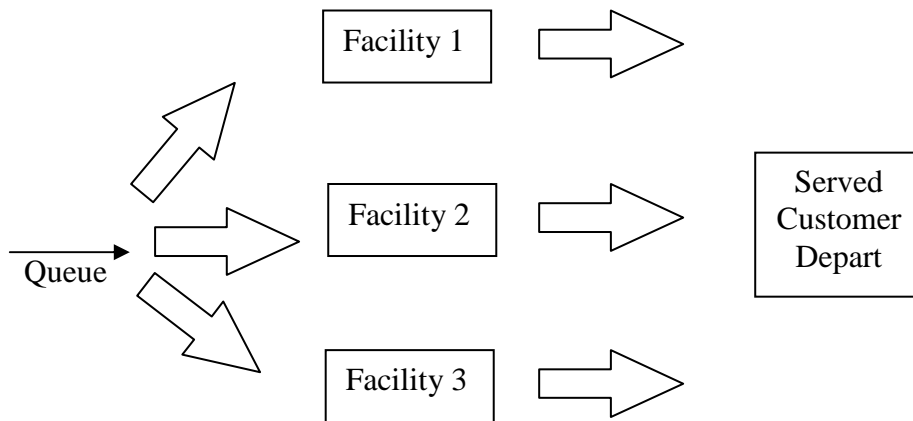

Fig. 9.3

(d) **Multiple parallel facilities with multiple queue.** Here there are a number of queues and separate facility to service each queue. Booking of tickets at railway stations, bus stands etc is a good example of this. This is shown in Fig. 9.4.

6. **Service Time.** Service time i.e., the time taken by the customer when the facility is dedicated to it for serving depends upon the requirement of the customer and what needs to be done as assessed by the facility provider. He arrival pattern is random so also is the service time required by all the customers is considered constant under the distribution. If the assumption of exponential distribution is not valid. Erlang Distribution is applied to the queuing model.

7. **Erlang Distribution.** It has been assumed in the queuing process we have seen that service is either constant or it follows negative exponential distribution in which case the standard deviation σ (sigma) is equal to its mean. This assumption makes the use of the of the exponential distribution simple. However, in cases where σ and mean are not equal, Erlang distribution

developed by AK Erlang is used. In this method, the service time is divided into number of phases assuming that total service can be provided by different phases of service. It is assumed that service time of each phase follows the exponential distribution i.e. $\sigma = \text{means}$

8. Traffic intensity or Utilisation Rate. This is the rate of at which the service facility is utilized by the components.

If $\lambda =$ mean arrival rate and

(Mute) $\mu =$ Mean service rate, then utilisation rate (p) = λ / μ it can be easily seen from the equation that $p > 1$ when arrival rate is more than the service rate and new arrivals will keep increasing the queue $p < 1$ means that service rate is more than the arrival rate and the waiting time will keep reducing as μ keeps increasing. This is true from the commonsense

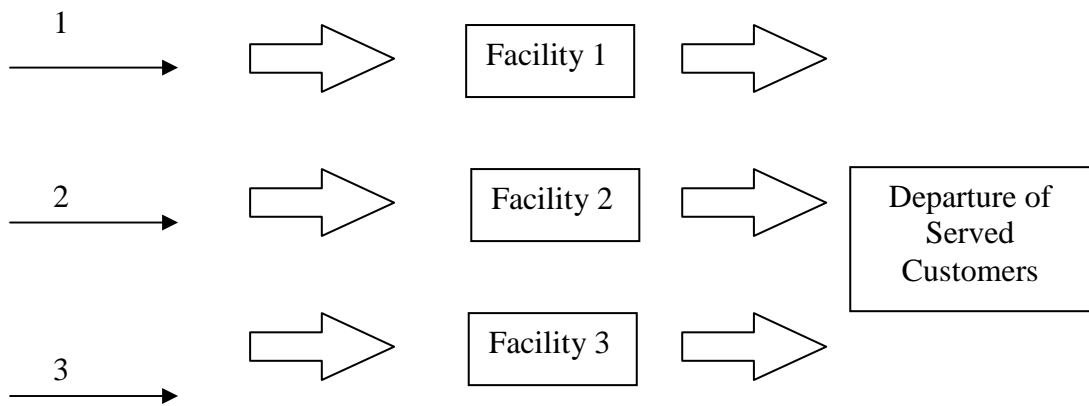

Fig. 9.4

9. Idle Rate. This is the rate at which the service facility remains unutilized and is lying idle

$$\text{Idle} = 1 - \text{utilisation} = 1 - p = \left(1 - \frac{\lambda}{\mu}\right) \times \text{total services facility} = \left(1 - \frac{\lambda}{\mu}\right) \times \frac{\lambda}{\mu}$$

10. Expected number of customer the system. This is the number of customer in queue plus the number of customers being serviced and is denoted by $E_n =$

$$\frac{\lambda}{(\mu - \lambda)}$$

11. Expected number of customer in queue (average queue length). This is the number of expected customer minus the number being serviced and is denoted

$$\text{by Eq. } E_q = E_n - p = \frac{\lambda}{(\mu - \lambda)} - \frac{\lambda}{\mu} = \frac{\lambda^2}{\mu(\mu - \lambda)}$$

12. **Expected time spent by in system.** It is the time that a customer spends waiting in queue plus the time it takes for servicing the customer and is

$$\text{denoted by } E_t = \frac{En}{\lambda} = \frac{\frac{\lambda}{(\mu - \lambda)}}{\lambda} = \frac{1}{(\mu - \lambda)}$$

13. **Expected waiting time in queue.** It is known that E_t = expected waiting time in queue + expected service time, therefore expected waiting time in queue
- $$(E_w) = E_t - \frac{1}{\mu}$$

14. **Average length of non-empty queue.** $E_l =$
- $$\frac{\mu}{(\mu - \lambda)} = \frac{1}{(\mu - \lambda)} - \frac{1}{\mu} = \frac{\lambda}{\lambda(\mu - \lambda)}$$

15. **Probability that customer wait is zero.** It means that the customer is attended to for servicing at the point of arrival and the customer does not wait at all. This depends upon the utilization rate of the service or idle rate of the system, $p_0 = 0$ persons waiting in the queue = $1 - \frac{\lambda}{\mu}$ and the probability of

1,2,3...n persons waiting in the queue will be given by $p_i =$

$$P_0 \left(\frac{\lambda}{\mu} \right)^1, P_2 = P_1 \left(\frac{\lambda}{\mu} \right)^2, P_n = P_0 \left(\frac{\lambda}{\mu} \right)^n$$

16. **Queuing Discipline.** All the customers get into a queue on arrival and are then serviced. The order in which the customer is selected for servicing is known as queuing discipline. A number of systems are used to select the customer to be served. Some of these are:

- (a) **First in First Served (FIFS).** This is the most commonly used method and the customers are served in the order of their arrival.
- (b) **Last in First Served (LIFS).** This is rarely used as it will create controversies and ego problems amongst the customers. Any one who comes first expects to be served first. It is used in store management, where it is convenient to issue the store last received and is called (LIFO) i.e. Last in First Out.
- (c) **Service In Priority (SIP).** The priority in servicing is allotted based on the special requirement of a customer like a doctor may attend to a serious patient out of turn, so may be the case with a vital machine which has broken down. In such cases the customer being serviced may be put on hold and the priority customer attended to or the priority may be put on hold and the priority customer attended to or the priority may be on hold and the priority customer waits till the servicing of the customer already being serviced is over.

17. **Customer Behaviour.** Different types of customers behave in different manner while they are waiting in queue, some of the patterns of behaviour are:

- (a) **Collusion.** Some customers who do not want to wait they make one customer as their representative and he represents a group of customers. Now only representative waits in queue and not all members of the group
- (b) **Balking.** When a customer does not wait to join the queue at the correct place which he warrants because of his arrival. They want to jump the queue and move ahead of others to reduce their waiting time in the queue. This behaviour is called balking.
- (c) **Jockeying.** This is the process of a customer leaving the queue which he had joined and goes and joins another queue to get advantage of being served earlier because the new queue has lesser customers ahead of him.
- (d) **Reneging.** Some customers either do not have time to wait in queue for a long time or they do not have the patience to wait, they leave the queue without being served.

18. **Queuing Cost Behaviour.** The total cost a service provider system incurs is the sum of cost of providing the services and the cost of waiting of the customers. Suppose the garage owner wants to install another car washing facility so that the waiting time of the customer is reduced. He has to manage a suitable compromise in his best interest. If the cost of adding another facility is more than offset by reducing the customer waiting time and hence getting more customers, it is definitely worth it. The relationship between these two costs is shown below.

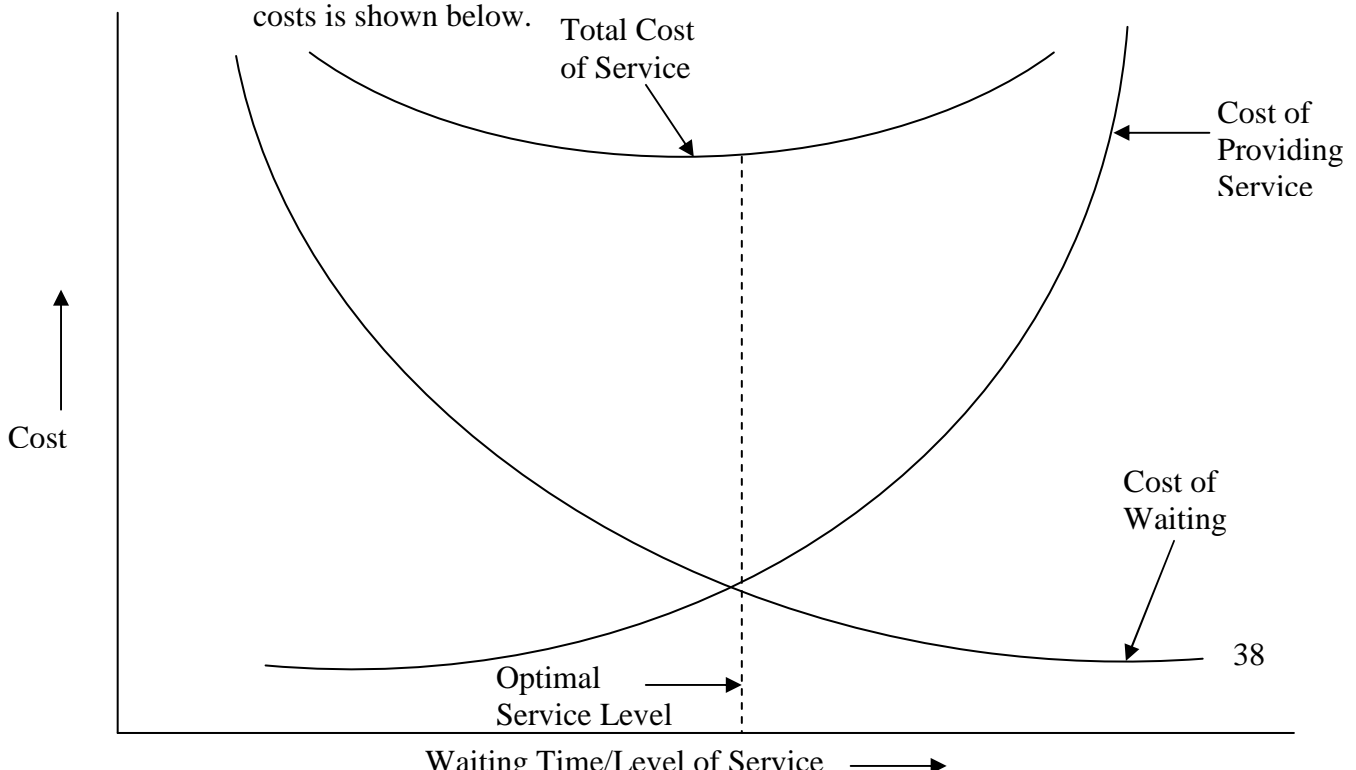

3.3.2 TYPES OF QUEUING MODEL

Different type of models are in use. The three possible types of categories are:

- (a) **Deterministic Model.** Where the arrival and service rates are known. This is rarely used as it is not a practical model.
- (b) **Probabilitistic Model.** Here both the parameters i.e., the arrival rate as also the service rate are unknown and are assumed random in nature probability distribution i.e. Poisson, Exponential or Erlang distributions are used.
- (c) **Mixed Model.** Where one of the parameters out of the two is known and the other is unknown

3.4 SINGLE CHANNEL QUEUING MODEL

(Arrival – Poisson and Service time Exponential)

This is the simplest queuing model and is commonly used. It makes the following assumptions:-

- (a) Arriving customers are served on First Come First Serve (FCFS) basis.
- (b) There is no Balking or Reneging. All the customers wait the queue to be served, no one jumps the queue and no one leaves it.
- (c) Arrival rate is constant and does not change with time
- (d) New customers arrival is independent of the earlier arrivals.
- (e) Arrivals are not of infinite population and follow Poisson's distribution
- (f) Rate of serving is known.

- (g) All customers have different service time requirement and are independent of each other
- (h) Service time can be described by negative exponential probability distribution
- (i) Average service rate is higher than the average and over a period of time the queue keeps reducing

Example 1. Assume a single channel service system of a library in a school. From past experiences it is known that on an average every hour 8 students come for issue of the books on an average rate of 10 per hour. Determine the following

- (a) Probability of the assistant librarian being idle
- (b) Probability that there are at least 3 students in system
- (c) Expected time that a student is in queue

Solution.

- (a) Probability that server is idle = $\left(\frac{\lambda}{\mu}\right)\left(1 - \frac{\lambda}{\mu}\right)$ in this example $\lambda = 8, \mu$

$$P_0 = \frac{8}{10}\left(1 - \frac{8}{10}\right) = 16\% = 0.16.$$

- (b) Probability that at least 3 students are in the system

$$E_n = \left(\frac{\lambda}{\mu}\right)^{n+1} = \left(\frac{8}{10}\right)^4 = 0.4$$

- (c) Expected time that a student is in queue

$$= \frac{\lambda^2}{\mu(\mu - \lambda)} = \frac{64}{(10 \times 2)} = 3.2 \text{ hours.}$$

Example 2. At a garage, car owners arrive at the rate of 6 per hour and served at the rate of 8 per hour. It is assumed that the arrival follows Poisson's distribution and the service pattern is exponentially distributed. Determine.

- (a) Average Queue length
- (b) Average waiting time

Solution.

Average arrival (mean arrival rate $\lambda = 6$ per hour

Average (mean) service rate $\mu = 8$ per hour

Utilisation rate (traffic intensity) $p = \frac{\lambda}{\mu} = \frac{6}{8} = 0.75$

- (a) Average Queue length $E_l = \frac{\lambda^2}{\lambda(\mu - \lambda)} = \frac{36}{[8(8 - 6)]} = 2.25 \text{ cars}$

$$(b) \quad \text{Average weighting time } E_t = \frac{1}{(\mu - \lambda)} = \frac{1}{2} = 30 \text{ minutes}$$

Example 3. customers arrive at a sales counter managed by a single person, according to a Poisson's process with a mean rate of 20 per hour. The time required to serve a customer has an exponential distribution with mean of 100 seconds. Find the average waiting time of a customer.

Solution

Mean arrival rate $\lambda = 20$ per hour

Average of mean service rate = 36 per hour as in 100 seconds one customer is served in 1 hour = 60 x 60 = 3600 seconds, 36 will be served Average waiting time of a customer in queue

$$E_w = \frac{\lambda}{\mu(\mu - \lambda)} = \frac{20}{36(36 - 20)} = \frac{5}{144} \text{ hours or } E$$

$$= \frac{5}{44} \times 60 = 2.08 \text{ minutes}$$

Average weighting time in the system $E_t =$

Example 4. Self-help canteen employs one cashier at its counter, 8 customers arrive every 10 minutes on an average. The cashier can serve at the rate of one customer per minute. Assume Poisson's distribution for arrival and exponential distribution for service patterns. Determine

- (a) Average number of customers in the system
- (b) Average queue length
- (c) Average time a customer spends in the system
- (d) Average waiting time of each customer.

Solution

Arrival rate $\lambda = \frac{8}{10}$ customers/minute

Service rate $\mu = 1$ customer/minute

- (a) Average number of customers in the system

$$E_n = \frac{\lambda}{\mu - \lambda} = \frac{0.8}{1 - 0.8} = 4$$

- (b) Average queue length

$$E_q = \frac{\lambda^2}{\mu(\mu - \lambda)} = \frac{(0.8)^2}{1 \times 0.2} = 3.2$$

- (c) Average time a customer spends in the queue

$$E_w = \frac{\lambda}{\mu(\mu - \lambda)} = \frac{0.8}{1 \times 0.2} = 4 \text{ minutes}$$

Example 5. A branch library of State Library has only one clerk is expected to perform various duties of issuing the book which are randomly distributed and can be approximated with Poisson's distribution. He is able to issue 12 books per hour. The readers arrive at the rate of 10 per hour during the 10 hours the library is open. Determine

- (a) Idle rate of the clerk
- (b) % time that the student has to wait
- (c) Average system time

Solution

• Arrival rate $\lambda = 10$ per hours

Service rate $\mu = 12$ per hour

(a) Idle rate $p = \frac{\lambda}{\mu} = \frac{10}{12} = 0.83$

(b) % time a student has to wait = % time the clerk is busy = 83%

(c) Average system time = $E_t = \frac{\lambda}{(\mu - \lambda)} = \frac{10}{12 - 10} = 5$ hours = 30 minutes

Example 6. An electrician repairs geysers, presses etc. He finds that the time he spends on repair of a geyser is exponentially distributed with mean 20 minutes. The geysers are repaired in the order in which these are received and their arrival approximates Poisson's distribution with an average rate 16 per 8 hours day. Determine

- (a) Electrician's idle time each day
- (b) How many geysers are ahead of the geyser just brought for repairs?

Solution

Arrival rate $\lambda = 2$ /hour

Service rate $\mu = 3$ /hour (One geyser is repaired in 20 minutes three will be repaired in one hour)

(a) Electrician idle time = 8 – utilization time.

$$= 8 - \frac{\lambda}{\mu} \times 8$$

$$= 8 - \frac{2}{3} \times 8 = \frac{8}{3} \text{ hours} = 2 \text{ hours } 40 \text{ minutes}$$

(b) Number of geysers ahead of the geyser just brought in = Average number of geysers in the system

$$E_n = \frac{\lambda}{(\mu - \lambda)} = \frac{2}{3 - 2} = 2$$

Example 7 Arrival rate of telephone calls at telephone booth are according to Poisson distribution, with an average time of 12 minutes between two consecutive

calls arrival. The length of telephone calls is assumed to be exponentially distributed with means 4 minutes

- Determine the probability that person arriving at the booth will have to wait
- Find the average queue length that is formed from time to time
- The telephone company will install second booth when convinced that an arrival would expect to have to wait at least 5 minutes for the phone. Find the increase in flows of arrivals which will justify a second booth.
- What is the probability that an arrival will have to wait for more than 15 minutes before the phone is free?
- Find the fraction of a day that the phone will be in use.

Solution

Arrival rate $\lambda = 1/12$ minutes

Service rate $\mu = 1/4$ minutes.

(a) Probability that a person will have to wait = $\frac{\lambda}{\mu} = \frac{1/12}{1/4} = \frac{1}{2} \times 4 = \frac{1}{3} = 0.33$

(b) Average queue length = $E_q = \frac{\lambda^2}{\mu(\mu - \lambda)} = \frac{1/144}{\frac{1}{4}(\frac{1}{4} - \frac{1}{12})} = \frac{1}{144} \times 4 \times \frac{12}{2} = 1 \text{ person}$

(c) Average waiting time in the queue $E_w = \frac{\lambda_1}{\mu(\mu - \lambda_1)} = \frac{\lambda_1}{\frac{1}{4}(\mu - \lambda_1)}$

$$5 = \frac{\lambda_1}{\frac{1}{4}(\frac{1}{4} - \lambda_1)}, \frac{5}{16} \left(\frac{5}{4} + 1 \right) \lambda_1$$

$$\lambda_1 = \frac{5}{16} \times \frac{4}{9} = \frac{5}{36} \text{ arrival/minute}$$

Increase in flow of arrival = $\frac{5}{36} - \frac{1}{12} = \frac{1}{18}$ minutes

(d) Probability of waiting time > 15 minutes

$$= \frac{\lambda}{\mu} e^{-(\lambda - \mu)t} = \frac{1/12}{1/4} e^{-(\frac{1}{12} - \frac{1}{4})15} = \frac{1}{3} 3^{-\frac{30}{12}} = \frac{1}{3e^{-2.5}}$$

(e) Fraction of a day that phone will be in use = $\frac{\lambda}{\mu} = 0.33$

Example 8. An emergency facility in a hospital where only one patient can be attended to at any one time receives 96 patients in 24 hours. Based on past

experiences, the hospital known that one such patient, on an average needs 10 minutes of attention and this time would cost Rs. 20 per patient treated. The hospital wants to reduce the queue of patients from the present number to $\frac{1}{2}$ patients. How much will it cost the hospital?

Solution

Using the usual notations $\lambda = \frac{96}{24} = 4$ patients /hour.

$\mu = \frac{1}{10} \times 60 = 6$ patients/hour.

Average expected number of patients in the queue = Eq = $\frac{\lambda^2}{\mu(\mu - \lambda)} = \frac{16}{6(6-4)} = \frac{16}{12} = \frac{4}{3}$ patients

This number is to reduced to $\frac{1}{2}$ therefore $\frac{1}{2} = \frac{16}{\mu_1(\mu_1 - 4)}$ or $\mu_1^2 - 4\mu_1 = 32$

Or

$\mu_1^2 - 4\mu_1 - 32 = 0$ or $(\mu_1 - 8)(\mu_1 + 4) = 0$ or $\mu_1 = 8$ patient per hours

For $\mu_1 = 8$ Average time required to attend to a patient = $\frac{1}{8} \times 60 = \frac{15}{2}$ minutes
 Decrease in time = $10 - \frac{15}{2} = \frac{5}{2}$ minutes.

Budget required for each patient = $100 + x \ 20 = \text{Rs } 150$

Thus to decrease the queue from 43 to $\frac{1}{2}$, the budget per patient will have to be increased from Rs 100 to Rs. 150

Example 9. Customers arrive at the executive class air ticketing at the rate of 10 per hour. There is only one airlines clerk servicing the customer at the rate of 20 hour. If the conditions of single channel queuing model apply to the problem i.e., arrival rate and service rate probability distribution are approximated to Poisson's and Exponential respectively; determine

- (a) System being idle probability.
- (b) The probability that there is not customer waiting to buy the ticket
- (c) The probability that the customer is being served and nobody is waiting

Solution

$\lambda = 10$ per hours $\mu = 20$ per hour

$P_n =$ Probability that there are n customer in the system

$$= \left(1 - \frac{\lambda}{\mu}\right) \left(\frac{\lambda}{\mu}\right)^n = \left(1 - \frac{10}{20}\right) \left(\frac{10}{20}\right)^4$$

$$= 0.5 (0.5)^n \text{ for values of } n = 1, 2, 3 \dots$$

- (a) System being idle probability or 0 customer at the counter = $p_0 = 1 - p_n = 1 - (0.5) \times (0.5)^0$
 $= 1 - 0.5 = 0.5$
- (b) Probability that there are more than 3 customers at the counter $p (>3) = \left(\frac{\lambda}{\mu}\right)^{3+1} = \left(\frac{10}{20}\right)^4 = (0.5)^4 = 0.06$
- (c) Probability that there is no customer waiting = Probability that at the most 1 customer is waiting = $p_0 + p_1 = 0.5 + 0.5 \times 0.5 = 0.5 + 0.25 = 0.75$
- (d) Probability of customers being served and no body is waiting
 $P_1 = 0.5 \times 0.5 = 0.25$

Example 10 An electricity bill receiving window in a small town has only one cashier who handles and issues receipts to the customers. He takes on an average 5 minutes per customer. It has been estimated that the persons coming for bill payment have no set pattern but on an average 8 persons come per hour.

The management receives a lot of complaints regarding customers waiting for long in queue and so decided to find out.

- (a) What is the average length of queue?
 (b) What time on an average, the cashier is idle?
 (c) What is the average time for which a person has to wait to pay his bill?
 (d) What is the probability that a person would have to wait for at least 10 minutes?

Solution

Making use of the usual notations

$$\lambda = 8 \text{ persons / hours}$$

$$\mu = 10 \text{ persons / hours}$$

(a) Average queue length = $\frac{\lambda^2}{\mu(\mu - \lambda)} = \frac{64}{10(10 - 8)} = 3.2$. Persons

(b) Probability that cashier is idle = $p_0 = 1 - \frac{\lambda}{\mu} = 1 - \frac{8}{10} = 0.2$ i.e., the cashier

would be idle for 20 % of his time.

(c) Average length of time that a person is expected to wait in queue.

$$E_w = \frac{\lambda}{\mu(\mu - \lambda)} = \frac{8}{10(10 - 8)} = 24 \text{ minutes}$$

(d) Probability that a customer will have to wait for at least 10 minutes

$$p(8) = \frac{\lambda}{\mu} \times e^{-(8-10) \times \frac{1}{6}} = \frac{8}{10} e^{-33}, t = \frac{1}{6} \text{ hours}$$

Example 11. A small town has only one bus stand where the bus comes every 10 minutes. The commuters arrive in a random manner to use the bus facility. The commuters have complained that they have to wait for a long times in a queue to board the bus. Average rate of arrival of commuters is 4 per hours. Calculate

- (a) the probability that a commuter has to wait.
- (b) The waiting time of the commuter

Solution

$$\lambda = 4 \text{ per hour}$$

$$\mu = 6 \text{ per hours}$$

- (a) Probability that a commuter has to wait

$$P_0 = 1 - \left(1 - \frac{\lambda}{\mu}\right) = \frac{\lambda}{\mu} = \frac{4}{6} = 0.66$$

There is a 66 percent probability that a commuter has to wait

- (b) Expected time spent by the commuter in a queue $E_t = \frac{1}{(\mu - \lambda)} = \frac{1}{6 - 4} = 0.5$
hours = 30 minutes

Example 12. A bank plans to open a single server drive-in banking facility at a particular centre. It is estimated that 28 customers with arrive each hour on an average. If on an average, it requires 2 minutes to process a customer transaction, determine

- (a) The probability of time that the system will be idle
- (b) On the average how long the customer will have to wait before receiving the server.
- (c) The length of the drive way required to accommodate all the arrivals. On the average 20 feet of derive way is required for each car that is waiting for service.

Solution

$$\lambda = 28 \text{ per hour}$$

$$\mu = \frac{60}{2} = 30 \text{ per hour}$$

$$\text{Traffic intensity } p = \frac{\lambda}{\mu} = \frac{28}{30} = 0.93$$

- (a) System idle $p_0 = 1 - P = 1 - .93 = 0.07$
7% of the time the system will be idle.
- (b) Average time a customer waiting in the queue $E_t = \frac{\lambda}{(\mu - \lambda)} = \frac{28}{60} = 28$
minutes
- (c) Average number of customers waiting $E_q = \frac{\lambda^2}{(\mu - \lambda)} = 28 \times \frac{28}{60} = 13$

Length of drive way = $13 \times 20 = 260$ feet.

Example 13 A factory manufacturing tanks for military use has a separate tool room where Special Maintenance Tools (SMTs) are stored. The average service time of the storekeeper is 9 minutes. Determine

- (a) Average queue length
 (b) Average length of no-empty queues.
 (c) Average number of mechanics in the system including one who is being attended to.
 (d) Mean waiting time of a mechanic
 (e) Average waiting time of mechanic who waits and
 (f) Whether there is a need of employing another storekeeper so that cost of storekeeper idle time and mechanic waiting is reduced to the minimum. Assuming that a skilled mechanic costs Rs. 10 per hour and the storekeeper costs Rs. 1 per hour.

Solution

Using the usual notations

$$\lambda = \frac{1}{10} \times 60 = 6 \text{ per hour}$$

$$\mu = \frac{1}{8} \times 60 = \frac{15}{2} \text{ per hour}$$

(a) Average queue length $E_q = \frac{\lambda^2}{\mu(\mu - \lambda)} = \frac{36}{\frac{15}{2} \left(\frac{15}{2} - 6 \right)} = \frac{36 \times 4}{45} = 3.2$

mechanics

- (b) Average number of workers / mechanics in the system

$$E_n = \frac{\lambda}{\mu - \lambda} = \frac{6}{\frac{15}{2} - 6} = 4 \text{ mechanics}$$

- (c) Mean waiting time of a mechanic in the system

$$E_t = \frac{E_n}{\lambda} = \frac{1}{\mu - \lambda} = \frac{1}{\frac{15}{2} - 6} = \frac{2}{3} = 40 \text{ minutes}$$

(d) Average waiting time of a mechanic in queue (or average time of a mechanic in queue) $E_r = \frac{1}{\mu - \lambda} = \frac{2}{3}$ hours = 40 minutes.

(f) Probability that the store keeper remains idle = $p_0 = \frac{1 - \lambda}{\mu} = \frac{3}{15} = 0.2$ Idle time

cost of one store keeper = $\frac{2}{10} \times 8 \times 1 = \text{Rs}1.6/\text{day}$ (assuming 8 hours working day)

Waiting time cost of mechanics = $\frac{E_w}{\text{hour}} \times 8 \times 10 = 0.53 \times 8 \times 10 = \text{Rs. } 42.4$

It can be seen that the time cost of mechanics is much higher than the idle time cost, it is reasonable to use another storekeeper.

Example 14 A large transport fleet employs vehicle repairmen on daily basis. The vehicle break down at an average rate of 4 per hour and the break down follows Poisson's distribution. Idle time of the vehicle cost Rs. 20/hour. Transport manager has the choice of selecting one out of two mechanics, one is a very efficient mechanic and for repairing 6 vehicles per hour. Assuming a working day of 8 hours, which mechanic should the transport manager hire?

Solution

Using the usual notations.

$$\lambda = 4 \text{ hours}$$

Idle time cost of a repairable vehicle = Rs 20/hours

Efficient mechanic case.

$$\lambda = 4 / \text{hours}$$

$$\mu = 6 / \text{hour}$$

Average number of vehicles in the system = $E_n = \frac{\lambda}{\mu - \lambda} = \frac{4}{6 - 4} = 2$ vehicles .

vehicle hours lost in 8 hours = $8 \times 2 = 16$ hours

Total cost per day = Cost of an idle-repairable vehicle + charges of mechanics

$$= (20 \times 16) + (25 \times 8)$$

$$= 320 + 200 = \text{Rs. } 520$$

Inefficient mechanic case

$$\lambda = 4 / \text{hour}$$

$$\mu = 5 / \text{hour}$$

$$E_n = \frac{\lambda}{\mu - \lambda} = \frac{4}{5 - 4} = 4 \text{ vehicles}$$

Vehicle hours lost in 8 hours = $8 \times 4 = 32$

Total cost per day = cost of repairable vehicle + charges of vehicles mechanics (20 x 32) + (15 x 8) = 640 + 120 = Rs. 760

Since the cost of engaging an inefficient mechanic is more than that of an efficient mechanic, the efficient mechanic should be hired.

Example 15. *Customer arrive at a one-windows-drive-in bank according to Poisson's distribution with mean 10 per hour. Service timer per customer is exponential with mean 5minutes. The space in front of the window, including for the service car accommodates a maximum of three cars. Other cars wait outside the space.*

- (a) *What is the probability than an arriving customer can drive directly to the space in front of the window?*
- (b) *What is the probability than an arriving customer will have to wait outside the indicate space?*

Solution

Using the usual notations

Here $\lambda = 10 / \text{hour}$

$$\mu = \frac{60}{5} \text{ 12/hour}$$

- (a) Probability that an arriving customer can directly drive to the space in front of the window. Since maximum of here cars can be accommodated, we must determine the total probability i.e. of p_0, p_1

$$p_0 = \frac{(\mu - \lambda)}{\lambda} = \frac{2}{12}$$

$$p_1 = \frac{\lambda}{\mu} (\mu - \lambda) \mu = \frac{10}{12} \times \frac{2}{12} = \frac{20}{144}$$

$$p_2 = \left(\frac{\lambda}{\mu}\right)^2 (\mu - \lambda) \mu = \frac{100}{144} \times \frac{2}{12} = \frac{200}{12 \times 144}$$

$$\text{Total probability} = \frac{2}{12} + \frac{20}{144} + \frac{200}{12 \times 144} = \frac{728}{144 \times 12} = 0.42$$

- (b) Probability that an arriving customer has to wait = 1 - 0.42 = 0.58

- (c) Average waiting time of a customer in the queue = E_w

$$= \frac{\lambda}{\mu(\mu - \lambda)} = \frac{10}{12(12 - 10)} = 0.417 \text{ hours}$$

$$= 25 \text{ minutes.}$$

Example 16. *ABC Diesel engineering works gets on an average 40 engines for overhaul per week, the need of getting a diesel engine overhauled is almost constant and the arrival of the repairable engines follows Poisson's distribution.*

However, the repair or overhaul time is exponentially distributed. An engine not available for use cost Rs. 500 per day. There are six working days and the company works for 52 weeks per year. At the moment the company has established the following overhaul facilities.

	Facilities	
	1	2
Installation charges	12,000,000	1600,000
Operating Expenses / year	200,000	3.50,000
Economic life (years)	8	10
Service Rate/Week	50	80

The facilities scrap value may be assumed to be nil. Determine which facility should be preferred by the company, assuming time value of money is zero?

Solution

Let us work out the total cost of using both the facilities.

Facility I

$\lambda = 40$ week, $\mu = 50$ /week

Total annual cost = Annual capital cost + Annual operating cost + Annual cost of lost time of overhaul able engines.

Expected annual lost time = (Expected time spent by repairable engines in system) x (Expected number of arrivals in a year).

$$Et = \frac{1}{\mu - \lambda} (\lambda \times \text{number of weeks}) = \frac{1}{50 - 40} \times 40 \times 52 = 208 \text{ weeks}$$

Cost of the lost time = Rs. 208 x 6 x 500 = 6,24,000

Total annual cost = $\frac{12,00,000}{8} + 2,00,000 + 6,24,000 = 1,50,000 + 2,00,000 + 6,24,000 = \text{Rs. } 9,74,000$

Facility 2.

Annual capital cost = $\frac{16,00,000}{10} + 3,50,000 + \text{cost of lost engine availability time.}$

cost of lost availability time = $Et \times (\lambda \times \text{number of weeks}) \times \frac{1}{(\mu - \lambda)} \times (\lambda \times \text{number of weeks})$

Here $\lambda = 40$
 $\mu = 80$

Hence, cost of lost availability time $\frac{1}{80 - 40} \times (40 \times 52) = \frac{2080}{40} = 52 \text{ weeks/year}$

Cost of lost time = 52 x 6 x 52 = Rs. 162245

$$\text{Total cost} = \frac{16,00,000}{10} + 3,50,000 + 162245 = \text{Rs. } 6,72,245$$

Hence facility No. 2 should be preferred to facility number one.

3.5 MULTI CHANNEL QUEUING MODEL (ARRIVAL POISSON AND SERVICE TIME EXPONENTIAL)

This is a common facilities system used in hospitals or banks where there are more than one service facilities and the customers arriving for service are attended to by these facilities on first come first serve basis. It amounts to parallel service points in front of which there is a queue. This shortens the length of the where he has to spend more time to shorter queue and can be serviced in lesser time. Following assumption are made in his model:

- (a) The input population is infinite i.e., the customers arrive out of a large number and follow Poisson's distribution.
- (b) Arriving customers from one queue
- (c) Customer are served on First come First served (FCFS) basis.
- (d) Service time follows an exponential distribution
- (e) There are a number of service station (K) and each one provides exactly the same service
- (f) The service rate of all service stations put together is more than arrival rate.

In this analysis we will use the following notations.

λ = Average rate of arrival

μ = Average rate of service of each of the service stations

K = Number of service stations

$K\mu$ = Mean combined service rate of all the service stations.

Hence ρ (row) the utilization factor for the system = $\frac{\lambda}{K\mu}$

$$(a) \quad \text{Probability that system will be idle } p_0 = \left[\sum_{n=0}^{K-1} \frac{\left(\frac{\lambda}{\mu}\right)^n}{n} + \frac{\left(\frac{\lambda}{\mu}\right)^k}{k(1-\rho)} \right]^{-1}$$

(b) Probability of n customers in the system

$$P_n = \frac{\left(\frac{\lambda}{\mu}\right)^n}{n} \times p_0 \quad n \leq k$$

$$P_n = \frac{\left(\frac{\lambda}{n}\right)^n}{k} K^{n-k} \times p_0 \quad n > k$$

- (c) Expected number of customer in queue or queue length

$$Eq = \frac{\left(\frac{\lambda}{\mu}\right)^n}{k(1-1)^2} \times p_0.$$

- (d) Expected number of customers in the system = $E_n = Eq + \frac{\lambda}{\mu}$

- (e) Average time a customer spends in queue

$$E_w = \frac{Eq}{\lambda}$$

- (f) Average time a customer spends in waiting line

$$= E_w + \frac{1}{\mu}$$

3.6 REVIEW AND DISCUSSION QUESTIONS

Example 17. A workshop engaged in the repair of cars has two separate repair lines assembled and there are two tools stores one for each repair line. Both the stores keep in identical type of tools. Arrival of vehicle mechanics has a mean of 16 per hour and follows a Poisson distribution. Service time has a mean of 3 minutes per machine and follows an exponential distribution. Is it desirable to combine both the tool stores in the interest of reducing waiting time of the machine and improving the efficiency?

Solution $\lambda = 16 / \text{hours}$

$$\mu = 1 \frac{1}{3} \times 60 = 20 \text{ hours}$$

Expected waiting time in queue, $E_w = \frac{\lambda}{\mu(\mu - \lambda)} = \frac{16}{20(20 - 16)} = 0.2 \text{ hours} = 12$

minutes. If we combine the two tools stores

$$\lambda = \text{Mean arrival rate} = 16 + 16 = 32 / \text{hour} \quad K = 2, n = 1.$$

$$\mu = \text{Mean service rate} = 20 / \text{hour}$$

$$\text{Expected waiting time in queue, } E_w = \frac{Eq}{\lambda} = \frac{\lambda \mu \left(\frac{\lambda}{\mu}\right)^k}{k - 1(K\mu - \lambda)^2} \times p_0$$

Where

$$\begin{aligned}
 p_0 &= \left[\sum_{n=0}^{K-1} \frac{\left(\frac{\lambda}{\mu}\right)^n}{k \left\{1 - \frac{\lambda}{k\mu}\right\}} \right]^{-1} \\
 &= \left[\sum_{n=0}^1 \frac{\left(\frac{32}{20}\right)^n}{n} + \frac{\left(\frac{32}{20}\right)^2}{2 - \left\{1 - \frac{32}{2 \times 24}\right\}} \right]^{-1} \\
 &= 0.182 \\
 Ew &= \frac{Eq}{\lambda} \times p_0 \\
 \frac{Eq}{\lambda} &= \frac{32 \left(\frac{32}{20}\right)}{2 - 1(40 - 32)^2} = \frac{32}{25}
 \end{aligned}$$

Hence

$$Ew = \frac{32}{25} \times 0.182 = 14 \text{ minute}$$

Since the waiting time in queue has increased it is not desirable to combine both the tools stores Present system is more efficient.

Example 18. XYZ is a large corporate house having two independent plants A and B working next to each other. Its production manager is concerned with increasing the overall output and so has suggested he two plants being combined with facilities in both the plants. The maintenance manager has indicated that at least 6 breakdown occur in plants a and b each in 12 hours shift and it follows the Poisson's distribution. He feels that when both the plants are combined on an average 8 breakdowns per shift will take place following Poisson's distribution. The existing service rate per shift is 9 and follows exponential distribution. The company management is considering tow options, one combining the two plan ts. This will increase the average service rate to 12, second retaining thw wo p[lants A and B and the capacity of serving in this will be 10 servicing per shift in each of the plants. Servicing/repair time follows exponential distribution. Which alternative will reduce the customer waiting time?

Solution

(First alternative) combining two plants.

$$\lambda = 8$$

$$\mu = 12$$

$$P_0 = 1 - \frac{\lambda}{\mu} = 1 - \frac{8}{12} = \frac{1}{3} = 0.33$$

Expected number of machines waiting for service (in queue) $Eq = \frac{\lambda^2}{\mu(\mu - \lambda)} = \frac{64}{48} =$

1.33

Expected time before a machine is repaired or

(Expected time spent by machine in a system) $\frac{1}{(\mu - \lambda)} = \frac{1}{12 - 8} = 0.25$ hours = 15

minutes

Second alternative (two channels) / having two plants.

$$P_0 = \left[\sum_{n=0}^{k-1} \frac{\left(\frac{\lambda}{\mu}\right)^n}{n} + \frac{\left(\frac{\lambda}{\mu}\right)^k}{k \left\{1 - \left(\frac{\lambda}{k\mu}\right)\right\}} \right]^{-1}$$

Here

$$k = 2, \lambda = 6$$

$$\mu = 10$$

$$P_0 = \left[1 + \frac{\left(\frac{6}{10}\right)}{1} + \frac{\left(\frac{36}{100}\right)^2}{2 \left(1 - \frac{6}{20}\right)} \right]^{-1}$$

$$P_0 = \left[1 + \left(\frac{6}{10}\right) + \left(\frac{36}{100} \times \frac{20}{28}\right) \right]^{-1} = \left(1 + \frac{6}{10} + \frac{36}{140}\right)^{-1}$$

$$= \left[\frac{140 + 84 + 36}{140} \right]^{-1} = \left(\frac{26}{14}\right)^{-1} = \frac{14}{26} = 0.54$$

$$Ew = \frac{Eq}{\lambda} = \frac{\mu \left(\frac{\lambda}{\mu}\right)^k}{k - 1(k\mu - \lambda)^2} \times P_0 = \frac{10 \times \frac{36}{100}}{196} \times 0.54$$

$$= \frac{36}{19600} \times 0.54$$

$$\text{or } \frac{10\left(\frac{6}{10}\right)^2}{2-1(2\times 10-6)^2} \times 0.54 = \frac{36}{100 \times 196} \times 0.54$$

$$\text{Expected number of machines waiting for service} = \frac{36}{19600} \times 0.54 = 0.0018$$

$$\text{Expected time before a machine is repaired} = 0.0018 \text{ hours} + \frac{1}{\mu} = 0.108 \text{ hours}$$

In 8 hours = 8 x 0.108 hours = 52 minutes

Single channel or combined facility has less waiting time as compared to having two plants hence combining the two plants is preferable.

Example 19. A bank has three different single window service counters. Any customer can get any service from any of the three counters. Average time of arrival of customer is 12 per hours and it follows Poisson's distribution. Also, on average the bank officer at the counter takes 4 minutes for servicing the service the customer twice as the bank officers to at present. If the only consideration of the bank is to reduce the waiting time of the customer which system is better?

Solution

. The existing system is a multi-channel system, using the normal notations here

$$\lambda = 12 / \text{hours} = \frac{60}{4} = 15 / \text{hour}$$

Average time a customer spends in the queue waiting to be served.

Eq = Average number of customer in the queue waiting to be served.

$$Eq = \frac{\lambda \mu \left(\frac{\mu}{\lambda}\right)^k}{k-1(k\mu-\lambda)^2} \times p_0$$

$$\text{Or } Ew = \frac{Eq}{\lambda} = \frac{\mu \left(\frac{\lambda}{\mu}\right)}{k-1(k\mu-\lambda)} \times p_0$$

$$\text{Where } p_0 = \left[\sum_{n=0}^{k-1} \frac{\lambda}{\mu} + \frac{\left(\frac{\lambda}{\mu}\right)}{k \left\{1 - \frac{\lambda}{k\mu}\right\}} \right]^{-1}$$

$$\text{Here } k = 3$$

$$p_0 = \left[1 + \frac{12}{15 \times 6} + \frac{\left(\frac{16}{25}\right)}{6 \left\{ 1 - \frac{12}{45} \right\}} \right]^{-1}$$

$$p_0 = \{1 + .133 + 0.66\}^{-1} = [1.193]^{-1} = 0.83$$

$$Ew = \frac{15 \left(\frac{12}{15}\right)^3}{2(18)^2} \times p_0 = 15 \times \frac{64}{(125 \times 2 \times 324)} \times p_0$$

$$= 15 \times 64 \times \frac{0.83}{(250 \times 324)} = 0.009 \text{ hours}$$

$$= .33 \text{ seconds}$$

Proposed system

$$Ew = \frac{\lambda}{\mu(\mu - \lambda)} \text{ here } \lambda = 12 / \text{hour}, \mu = 15 / \text{hour}, Ew = \frac{12}{15(15 - 12)} = \frac{12}{45} \times$$

60

$$= 16 \text{ minutes}$$

Hence, it is better to continue with the present system rather than installing ATM purely on the consideration of customer waiting time.

Example 20. At a polyclinic three facilities of clinical laboratories has been provided for blood testing. Three Lab technicians attend to the patients. The technicians are equally qualified and experienced and they 30 minutes to serve a patient. This average time follows exponential distribution. The patients arrive at an average rate of 4 per hour and this follows Poisson's distribution. The management is interested in finding out the following:-

- Expected number of patients waiting in the queue
- Average time that a patient spends at the polyclinic
- Probability that a patient must wait before being served
- Average percentage idle time for each of the lab technicians

Solution

In this example

$$\lambda = 4 / \text{hour}$$

$$\mu = \frac{1}{30} \times 60 = 2 / \text{hour}$$

$$K = 3$$

P_0 = Probability that there is no patient in the system

$$\begin{aligned}
 &= \left[\sum_{n=1}^{k-1} \frac{1}{n} \left(\frac{\lambda}{\mu} \right)^n + \frac{1}{n} \frac{\left(\frac{\lambda}{\mu} \right)^n}{\left(1 - \frac{\lambda}{k\mu} \right)} \right]^{-1} \\
 &= \left[\frac{1}{0} + \frac{2}{2} + \frac{2^2}{2} + \frac{1}{16} (2)^3 \times \frac{1}{1} - \frac{4}{6} \right]^{-1} = \left[1 + \frac{2^1}{2} + \frac{2^2}{2} + \frac{(2)^3}{2 \times \frac{2}{6}} \right]^{-1} \\
 &= \left[1 + 1 + 2 \frac{8 \times 6}{4} \right]^{-1} = (26)^{-1} = 0.038
 \end{aligned}$$

(a) Expected number of patients waiting in the queue

$$\begin{aligned}
 Eq &= \frac{1}{k-1} \left(\frac{\lambda}{\mu} \right)^k \frac{\lambda}{(k\mu - k)^2} \times p_0 \\
 &= \left[\frac{1}{2} \times 8 \times \frac{8}{4} \right] \times 0.038 = 8 \times 0.038 = 0.304 \text{ or one patient}
 \end{aligned}$$

(b) Average time a patient spends in the system

$$= \frac{Eq}{\lambda} + \frac{1}{\mu} = \frac{0.304}{4} + \frac{1}{2} = 0.076 + 0.5 = 0.576 \text{ hours} = 35 \text{ minutes}$$

(c) Probability that a patient must wait

$$\begin{aligned}
 P(n \geq k) &= \frac{1}{k} \left(\frac{\lambda}{\mu} \right)^k \frac{1}{\left(\frac{1-\lambda}{k\mu} \right)} \times p_0 \\
 &= \frac{1}{6} \times 8 \times 8 \times 0.038 \\
 &= 0.40
 \end{aligned}$$

(d) $p(\text{idle technician}) = \frac{3}{3} p_0 + \frac{2}{3} p_1 + \frac{1}{3} p_2$ when $p_n = \frac{1}{n} \left(\frac{\lambda}{\mu} \right)^n p_0$

P_0 = when all the 3 technician are idle (no one is busy)

P_1 = when only one technician is idle (two are busy)

P_2 = when two technicians are idle (only one busy)

$$\begin{aligned}
 P(\text{idle technician}) &= \frac{3}{3} \times 0.038 + \frac{2}{3} \times \left(\frac{4}{2} \right) \times 0.038 + \frac{1}{3} \times \frac{1}{2} (2)^2 \times 0.038 \\
 &= 0.038 + 0.05 + 0.25 \\
 &= 0.113
 \end{aligned}$$

Example 21 A telephone exchange has made special arrangement for ISD long distance calls and placed two operators for handling these calls. The calls arrive at an average rate of 12 per hour and follow Poisson's distribution. Service time for such calls is on an average 6 minutes per call and it follows exponential distribution. What is the probability that a subscriber will have to wait for his ISD call? What is expected waiting time? Assume that the policy of First cum First served (FCFS) is followed.

Solution

Using usual notations

$$\lambda = 12 \text{ calls per hour}$$

$$\mu = \frac{60}{6} \times 6 = 10 \text{ calls per hour}$$

$$K = 2$$

(a) Probability that a subscriber has to wait

$P(n \geq 2) = (p_0 + p_1)$ as there are two operators, a subscriber will have to wait only if there are either 2 or more than 2 calls.

$$\begin{aligned} p_0 &= \left[\sum_{n=0}^{k-1} \frac{1}{n} \left(\frac{\lambda}{\mu}\right)^n + \frac{1}{k} \left(\frac{\lambda}{\mu}\right)^k \frac{1}{\left(\frac{1-\lambda}{k\mu}\right)} \right]^{-1} \\ &= \left[\frac{1}{0} + \frac{1}{1} \left(\frac{12}{10}\right) + \frac{1}{2} \left(\frac{12}{10}\right)^2 + \frac{1}{3} \left(\frac{12}{10}\right)^3 \frac{1}{\left(\frac{1-12}{30}\right)} \right]^{-1} \\ &= \left[1 + \frac{6}{5} + 0.72 + \frac{1}{6} \times \frac{1}{2} \left(\frac{12}{10}\right)^2 + \frac{1}{3} \left(\frac{12}{10}\right)^3 \frac{1}{\left(\frac{1-12}{30}\right)} \right]^{-1} \\ &= \left[1 + \frac{6}{5} + 0.72 + \frac{1}{6} \times \frac{1728}{1000} \times \frac{30}{18} \right]^{-1} \\ &= \left[1 + 1.2 + 0.72 + \frac{1}{6} \right]^{-1} = (3.4)^{-1} = \frac{1}{3.4} = 0.294 \end{aligned}$$

$$\begin{aligned} p_1 &= \frac{1}{n} \left(\frac{\lambda}{\mu}\right)^n \times p_0 \\ &= \frac{1}{1} \left(\frac{12}{10}\right) \times 0.294 = 0.352 \end{aligned}$$

$$\begin{aligned} P(n > 2) &= 1 - (p_0 + p_1) = 1 - (0.294 + 0.352) = 1 - 0.646 \\ &= 0.354 \end{aligned}$$

(b) Expected waiting time for subscriber = $\frac{\mu \left(\frac{\lambda}{\mu}\right)^k}{k - 1(k\mu - \lambda)} \times p_0$

$$\begin{aligned} &= \frac{10 \left(\frac{12}{10}\right)^2}{1(20 - 12)^2} \times 0.294 \\ &= \frac{(14.4 \times 0.294 \times 60)}{64} = 3.97 \text{ minutes} \end{aligned}$$

Example 22. A general insurance company handles the vehicle accident claims and employs three officers for this purpose. The policy holders make on an average 24 claims during 8 hours working day and it follows the Poisson's distribution. The officers attending the claims of policy holders spend on an average 30 minutes per claim and this follows the exponential distribution. Claims of the policy holders are processed on first served basis. How many hours does the claim officers spend with the policy holder per day?

Solution

$$\text{Arrival rate } \lambda = \frac{24}{8} = 3 \text{ claims / hours}$$

$$\text{Service rate } \mu = \frac{60}{30} = 2 \text{ claims/ hours}$$

Probability that no policy holder is with bank officer

$$\begin{aligned} p_0 &= \left[\sum_{n=0}^{k-1} \frac{1}{n} \left(\frac{\lambda}{\mu} \right)^n + \frac{1}{\mu} \left(\frac{\lambda}{\mu} \right)^k \frac{1}{\left(\frac{1-\lambda}{k\mu} \right)} \right]^{-1} \\ &= \left[\frac{1}{0} + \frac{1 \cdot 3}{1 \cdot 2} + \frac{1}{2} \left(\frac{3}{2} \right)^2 + \frac{1}{6} \left(\frac{3}{2} \right)^3 \frac{1}{\left(1 - \frac{3}{6} \right)} \right]^{-1} \\ &= \left[1 + \frac{3}{2} + \frac{8}{9} + \frac{8}{9} \right]^{-1} = \left(\frac{(8+12+9+9)}{8} \right)^{-1} = \frac{8}{38} = 0.21 \end{aligned}$$

Probability that one policy holder is with bank officer

$$P_1 = \frac{1}{n} \left(\frac{\lambda}{\mu} \right)^1 \times p_0 = 1 \times \frac{3}{2} \times 0.21 = 0.315$$

Probability that two policy holders are with bank officer

$$P_2 = \frac{1}{n} \left(\frac{\lambda}{\mu} \right)^2 \times p_0 = 1 \times \left(\frac{3}{2} \right)^2 \times 0.21 = \frac{1.89}{8} = 0.236$$

Expected number of bank officers being idle

$$\begin{aligned} &= \text{All three idle} + \text{any two idle} + \text{one idle} \\ &= 3p_0 + 2p_1 + 1p_2 \\ &= 3 \times 0.21 + 2 \times 0.315 + 1 \times 0.236 = 0.63 + 0.630 + 0.236 = 0.866 \end{aligned}$$

Probability of any bank officer not remaining idle = $1 - 0.21 = 0.79$

Time bank officers will spend with the policy holder per day = $0.79 \times 8 = 6.02$

Hours (Assuming 8 hours working day)

Example 23. A new company, entering the business of repair and maintenance of small generators for household use, want to decide about the number of mechanics and other related tool for repair of such generators. The company has no experience of its own but has carried out a survey and determined that such generators would need repair at the rate of one generator every 5 hours and this follows Poisson's distribution. If only one mechanic is used, his mean repair time is two per hour and it

follows the exponential distribution. It is estimated that generator down time cost is Rs. 60 per hour and the generator repair cost Rs. 100 per day of 8 hours. Calculate the expected number of operating generators and expected down time work per day. Would you recommend the company to employ two mechanics each repairing generators out of the total 4 rather than only one mechanic repairing all the four generators?

Solution

In usual notations we have

$$\text{Arrival rate } (\lambda) = \frac{1}{4} \text{ f / hour}$$

$$\text{Service rate } (\mu) = 2/\text{hour, } n = 4$$

Probability of no generator in the repair shop

$$\begin{aligned} p_0 &= \left[\sum_{n=0}^{k-1} \frac{1}{n} \left(\frac{\lambda}{\mu} \right)^n + \frac{4}{2} + \left(\frac{\lambda}{\mu} \right)^4 \frac{n}{(n-4)} \right]^{-1} \\ &= \left[1 + \frac{1}{8} \frac{3}{2} + \left(\frac{1}{8} \right)^2 \frac{4}{2} + \left(\frac{1}{8} \right)^3 \frac{4}{2} + \left(\frac{1}{8} \right)^4 \frac{4}{0} \right]^{-1} \\ &= \left[1 + \frac{1}{2} + \frac{3}{16} + \frac{3}{64} + \frac{3}{1024} \right]^{-1} \\ &= [1+0.5 + 0.187 + 0.046 + 0]^{-1} = (1.733)^{-1} = 0.577 \end{aligned}$$

Expected number of generators in the repair shop

$$= [(1 \times p_1) + 2 \times p_2 + 3 \times p_3 + 4 \times p_4]$$

Where

$$p_n = \frac{1}{n} \left(\frac{\lambda}{\mu} \right)^n \cdot p_0$$

$$P_1 = \frac{1}{0} \left(\frac{1}{8} \right)^0 \times p_0 = 0.577$$

$$P_2 = \frac{1}{1} \left(\frac{1}{8} \right)^1 \times p_0 = \frac{0.577}{8}$$

$$P_3 = \frac{1}{2} \left(\frac{1}{8} \right)^2 \times p_0 = \frac{0.577}{128}$$

$$P_4 = \frac{1}{3} \left(\frac{1}{8} \right)^3 \times p_0 = \frac{0.577}{3072}$$

$$= \left(0.577 + 2 \times \frac{0.577}{8} + 3 \times \frac{0.577}{128} + 4 \times \frac{0.577}{3072} \right)$$

=

$$0.577 \left(1 + \frac{1}{4} + \frac{3}{42.6} + \frac{4}{768} \right) = 0.577(1 + 0.25 + 0.046 + 0.005)$$

$$= 0.577 \times 1.301 = 0.7501$$

Or 1 generator approximately

Expected number of operating generators = 4 – 1 = 3 generators. Expected down time cost per day = 8 x 60 = Rs 480 per generator. Total break down cost of generator = Expected down time cost + cost of generator repair = 480 + 100 = Rs. 580.

Second case. When two mechanics repair two generators each

$$K = 2, \quad n = 2$$

P_0 = Probability of no generator in repair – shop

$$\begin{aligned} &= \left[\sum_{n=0}^{k-1} \frac{1}{n} \left(\frac{\lambda}{\mu} \right)^n + \frac{1}{k} \times \frac{1}{\left(\frac{1-\lambda}{k\mu} \right)} \right]^{-1} \\ &= \left[1 + 1 \times \frac{1}{8} + \frac{1}{2} \times \left(\frac{1}{8} \right)^2 + \frac{1}{2} \times \frac{1}{\left(1 - \frac{1}{4} / 4 \right)} \right]^{-1} \\ &= \left[1 + \frac{1}{8} + \frac{1}{128} + \frac{1}{2} \times \frac{4}{15} \right]^{-1} \\ &= [1 + 0.125 + 0.007 + 0.133]^{-1} = (1.265)^{-1} = 0.79 \end{aligned}$$

Expected number of generators in the repair shop for each mechanic

$$= 1 \times p_1 + 2p_2$$

$$P_1 = \frac{1}{1} \times \frac{1}{8} \times p_0 \text{ where } p_n = \frac{1}{n} \times \left(\frac{\lambda}{\mu} \right)^n \times p_0$$

$$P_2 = \frac{1}{2} \left(\frac{1}{8} \right)^2 p_0 = \frac{1}{128} p_0$$

Expected number of generators

$$\begin{aligned} &= \frac{1}{8} p_0 + 2 \times \frac{1}{128} p_0 = 0.79 \left(\frac{1}{8} + \frac{1}{64} \right) \\ &= 0.79 \times \frac{9}{64} = 0.11 \end{aligned}$$

Total down time cost of generators

$$= 0.11 \times 2 \times 60 = \text{Rs } 105$$

Total break down cost of generators = down time cost + cost of two mechanics

$$= \text{Rs. } (105 + 2 \times 100) = \text{Rs}305$$

It may be seen that the total break down cost is lesser when two mechanics are used for repairing two generators each, hence this option is preferable

8.0 CONCLUSION

As in summary

9.0 SUMMARY

1. Another name for queue is waiting line.
2. In a simple queue having only one server assumptions in analysis of queue theory are as follows; (a) Arrival pattern is poisson while (b) Service time is negative exponential (c) The traffic intensity is less than 1 and the queue discipline is FIFO.
3. FIFO means First – in- first-out
4. LIFO means Last-in-First- out
5. SIRO means service – in- random – order
6. PR means priority ordering
7. GD means any other specified ordering
8. Analysis can also be done with respect to average number in (a) The system (b) IN queue c) in queue when there is a queue.
9. Analysis can also be done with respect to time consideration.
10. Chance consideration involving probability estimates
11. Cost consideration involving service cost, waiting cost and total expected cost of the queue system
12. When level of service increases cost of service increases while customers waiting time decreases resulting in decrease in expected waiting cost and increase in server's idle time.
13. Traffic intensity $P = \frac{\text{Arrival rate}}{\text{Service rate}} = u$
14. This also give us the probability that a customer has to wait for service i.e. queue on arrival.

15. Probability of receiving immediately service i.e. not queue on arrival is $1 - p$.
16. For a single channel system NU is often called the utilization factor for the system since it gives the probability that we have to queue since the service facility is busy.
17. System utilization $r = NCH$ where C is the number of servers or channels.
18. Average number of items in the system i.e. who are either being served or waiting to be served is $P/(1-p)$.
19. Average number or queue = no in system no being served
20. $= \frac{P}{1-p} - p = \frac{p - p + p^2}{1-p} = \frac{p^2}{1-p}$
21. $1 - p$
22. Average number in queue when a queue actually exist $1/1 - p$
23. Average time in system = $1/(U - z)$
24. Average time in queue = $p/(u - z)$
25. Probability of N items in system = $(1 - p)^n$
26. Probability of more than N items in the system = p^n
27. Total Cost = Service cost + queuing cost
28. The traffic intensity number consideration, chance consideration from the operating characteristics of a system.
29. For multiple channel system the following operations characteristics holds.

10.0 TUTOR MARKED ASSIGNMENT

1. You have been asked to consider three systems of providing service when customers arrive with a mean arrival rate of 24 per hour.

1. Single channel with a mean service rate of 30 per hour at Rs. 5 per customer with a fixed cost of Rs. 50 per hour.
2. 3 channels in parallel each with a mean service rate of 10 per hour at Rs. 3 per customer and fixed cost of Rs. 25 per hour per channel. It is confirmed that the systems are identical in all other aspects with a simple queue. Average time a customer is in the system is given by

$$\frac{(pc)^c}{c(1-p)^2 C\mu} \times p_0 + \frac{1}{\mu} \times \text{where symbols have usual meaning}$$

and

$$p_0 = 0.2 \text{ when } c = 1$$
$$p_0 = 0.111 \text{ when } c = 2$$
$$p_0 = 0.056 \text{ when } c = 3$$

you are required to calculate

- (i) The average time a customer is in the system when 1, 2, 3 channels are in use.
- (ii) The most economical system to adopt if the value of the customer's time is ignored and to state the total cost per hour of this system.

2 Maintenance of machine can be carried out in 5 operations which have to be performed in a sequence. Time taken for each of these operations. Has a mean time of 5 minutes and follows exponential distribution. The break down of machine follows Poisson distribution and the average rate of break down is 3 per hour. Assume that there is only one mechanic available, find out the average idle time for each machine break down.

3. A servicing garage carries out the servicing in two stages. Service time at each state is 40 minutes and follows exponential distribution. The arrival pattern is one car every 2 hours and it follows Poisson's distribution. Determine.

- (a) Expected number of customer in the queue
- (b) Expected number of vehicles in the system
- (c) Expected waiting time in the system
- (d) Expected time in the system.

4. In a restaurant, the customers are required to collect the coupons after making the payment at one counter, after which he moves to the second counter where he collects the snacks and then to the third counter, where he collects the cold drinks. At each

counter he spends $1 \times \frac{1}{2}$ minutes on an average and this time of service at each counter is exponentially distributed. The arrival of customer is at the rate of 10 customers per hour and it follows Poisson's distribution. Determine.

- (a) Average time a customer spends waiting in the restaurant
- (b) Average time the customer is in queue

7.0. REFERENCES/FURTHER READING

1. Operations Research. By Prem Kumar Gupta and D.S. Hira
2. Operations Research. (Problem Solvers) By Research and Education Association.
29. Statistics and Operations Research. By Debashis Dutta
30. Operations Research By. O.T. Arowolo and G.O. Lawal

UNIT 5

REPLACEMENT THEORY

CONTENTS

29.0	Introduction
30.0	Objective
31.0	Main Content
31.1	Replacement of items which deteriorate with time without considering the change in money value .
31.2	Replacement policy of an equipment whose operating cost increases with time and money value also changes with time.
31.3	Replacement policy for equipment that fails suddenly
31.4	Group replacement policy
31.5	Manpower replacement policy
32.0	Conclusion
33.0	Summary
34.0	Tutor Marked Assignment
35.0	References/Further Readings

2.0 INTRODUCTION

Replacement of old plant and equipment and items of use like bulbs/tube-lights, refrigerators/heating tools/gadgets etc is a necessity. All these items are designed for performance upto the desired level for a particular time (years/hours) or particular number of operations. For example, when a refrigerator is given the warranty for 7 years the manufacturer knows that the design of the refrigerator is such that it will perform up to desired level of efficiency without breakdown for that period. Similarly, bulbs/tube-lights may have been designed for say 10,000 on-off operations. But all these need to be replaced after a particular period/number of operations. The equipment is generally replaced because of the following reasons:-

- a. when the item/equipment fails and does not perform its function it is meant for
- b. Item/equipment has been in use for sometimes and is expected to fail soon.
- c. The item/equipment in use has deteriorated in performance and needs expensive repairs i.e. it has gone beyond the economic repair situations. The cost of maintenance and repair of equipment keeps increasing with the age of the equipment. When it becomes uneconomical to continue with an old equipment, it must be replaced by a new equipment.
- d. Improve technology has given access to much better (convenient to use) and technically superior (using less power) products. This is the case of

obsolesce. The equipment needs to be replaced not because it does not perform up to the standard it is designed for but because new equipment is capable of performance of much higher standards.

It should be understood that all replacement decisions involve high financial costs. The financial decisions of such nature will depend upon a large number of factors, like the cost of new equipment, value of scrap, availability of funds, cost of funds that have to be arranged, tax benefits, government policy etc.

When making replacement decisions, the management has to make certain assumptions, these are

- a. The quality of the output remains unchanged.
- b. There is no change in the maintenance cost
- c. Equipments perform to the same standards

Let us discuss some of the common replacement problems.

2.0 OBJECTIVES

By the end of this unit the reader will be able to:

- Understanding that depreciable assets have to be replaced
- Formulation of assumption of Replacement Theory
- Understanding replacement policy for such items whose maintenance cost increases with time and also the money value changes with time (at constant rate).
- understand the mechanism of system failing suddenly
- Discuss group replacement policy

3.0 MAIN CONTENT

3.1 Replacement of items which deteriorate with time without considering the change in money value

Most of the machinery and equipment having moving parts deteriorate in their performance with passage of time. The cost of maintenance and repair keeps increasing with passage of time and a stage may reach when it is more economical (in overall analysis) to replace the item with a new one. For example, a passenger car is bound to wear out with time and its repair and maintenance cost may go to such level that the owner has to replace it with a new one.

Let C = capital cost of the item

$S(t)$ = scrap value of the item after t years of use.

$O(t)$ = Operating and maintenance cost of the equipment at time t .

n = number of years the item can be used.

$TC(n)$ = Total cost of using the equipment for n years

$$TC(n) = C - S(t) + \sum_{t=1}^n O(t)$$

$$\text{Average TC (n)} = \frac{1}{n} \left[C - S(t) + \sum_{T=1}^N O(t) \right]$$

Time 't' in this case is a discrete variable

In this case as long as the average TC (n) is minimum, the equipment can remain in use for that number of years. If average total cost keep decreasing up to *i*th year and starts increasing from (*I* + 1)th year then *i*th year may be considered as most economic year for replacement of the equipment.

The concept of depreciation cost also must be understood here. As the years pass by, the cost of the equipment or items keeps decreasing. How much the cost keeps decreasing can be calculated by two methods commonly used. i.e. straight line depreciation method and the diminishing value method.

Example 1. A JCB excavator operator purchases the machine for #15,00,000. The operating cost and the resale value of the machine is given below

Year	1	2	3	4	5	6	7	8
Operating Cost (#'000)	30	32	36	40	45	52	60	70
Resale Value (#'000)	12	10	8.9	5	4.5	4	3	2

When should the machine be replaced?

Solution

C. = #15,000

O(t) = Operating cost

S (t) = Resale value

t = Time

n = Number of years after when the machine is to replaced.

Let us draw a table showing the various variables required o make decision. This is shown in the table below.

Year	O(t) (in thousand)	Cumulative O(t)	Resale value S (t)	Depreciation C-S (t) in	Total cost TC(n)	Average TC(n)
------	--------------------	-----------------	--------------------	-------------------------	------------------	---------------

	<i>d</i> <i>of Naira</i>)		in thousan d of Naira	thousand of Naira	Thousand s of Naira	Thousand s of Naira
1	30	30	1200	300	330	330
2	32	62	1000	500	562	281
3	36	98	800	700	798	266
4	40	138	500	1000	1138	284.5
5	45	183	450	1050	1233	246.6
6	52	235	400	1100	1355	222.5
7	60	295	300	1200	1495	213.6
8	70	365	200	1300	1665	208

In 3rd year the minimum average cost is 2,66,000 as shown in he table above. So replacement should take place at the end of 3rd year

3.2 STEPS INVOLVED IN CALCULATION OF RELACEMENT POLICY WHEN MONEY VALUE CHANGES

Step I. Find out the present value factor at the given rate and multiply it with the operating/maintenance cost of the equipment/items for different years.

Step II. Work out the total cost by adding the cumulative present value to the original cost for all the years

Step III. Cumulate the discount factors

Step IV. Divide the total cost by corresponding value of the cumulated discount factor for every year

Step V. Find out the value of last column that exceeds the total cost. Equipment/item will be replaced in he latest year

These steps will be explained with the help of an example.

Example 2. *The yearly cost of two machine X and Y, when money value is neglected is shown below. Find which machine is more economical if money value is 10% per year.*

<i>Year</i>	<i>1</i>	<i>2</i>	<i>3</i>
<i>Machine X (#)</i>	<i>2400</i>	<i>1600</i>	<i>1800</i>
<i>Machine Y (#)</i>	<i>3200</i>	<i>800</i>	<i>1800</i>

Sol. It may be seen hat the total cost for each machine X and Y is # 5800 (2400 + 1600 + 1800) or (3200 + 800 + 1800). When th`e money value is not discounted the machines are equally good, total cost wise, when money value is not changed with time, with money value 10% per year, the discount rate, it changes as follows

$$V = \frac{1}{1+r} + r = \frac{1}{1+0.10} = \frac{1}{1.1} = 0.9091$$

$$1 = 0.9091$$

Discounted costs are obtained by multiplying the original costs with 0.9091 after one year. Total cost of machines X and Y are calculated as shown below:

Year	1	2	3	Total cost (#)
Machine X	2400	1600 x 0.9091 = 1440	1800 x 0.9081 =1620	5460
Machine Y	3200	800 x 0.9091 = 720	1620	5540

The total cost of machine X is less than that of machine Y, machine X is more economical.

Example 3. The cost of a new machine is # 5000 the maintenance cost during n th year is given by $M_n = \$ 500 (n - 1)$ where $n = 1, 2, 3, \dots$. If the discount rate per year is 0.05, after how many years will it be economical to replace the machine by a new one?

Sol. The discounted rate is given as 0.05 i.e. 5% then the present value.

$$V = \frac{1}{1+r} = \frac{1}{1+0.05} = 0.9523 \text{ after one year. After 2 years it will be } (.9523)$$

Year	Maintenance Cost	Discounted Cost	Discounted Maintenance Cost	Cumulative Total Discounted Cost	Average Total Cost
1	0	1.0	0	5000	5000
2	500	0.9523	467	5476	2738
3	1000	0.9070	907	6383	2127
4	1500	0.8638	1296	7679	1919
5	2000	0.8227	1645	9324	1865
6	2500	0.7835	1959	11283	1880

From above it is clear that it will be economical to replace the machine after 5th year

3.3 REPLACEMENT POLICY FOR EQUIPMENT/POLICY THAT BREAKS DOWN/FAILS SUDDENLY

As an equipment or item, which is made of a number of components ages with time, it deteriorates in its functional efficiency and the performance standard are reduced. However, in real life situation there are many such items whose performance does not deteriorate with time but fail suddenly without any warning. This can cause immense damage to the system or equipment and inconvenience to the user. When the item deteriorates with time, one is expecting reduced performance but other items, which may fail without being expected to stop performing, can create a lot of problems. A

minor component in an electronic device or equipment like TV, fridge or washing machine, costs very little and may be replaced in no time but the entire equipment fails suddenly if the fails. Hence the cost of failure in terms of the damage to the equipment and the inconvenience to the user is much more than the cost of the item.

If it is possible to know exactly the life of the component it is possible to predict that the component and hence equipment is likely to fail after performance of so many hours or miles etc. this is the concept of preventive maintenance and preventive replacement. If the equipment is inspected at laid down intervals to know its conditions, it may not be possible to expect the failure of the item. The cost of failure must be brought down to minimum, preventive maintenance is cheap but avoids lots of problems. In many cases, it may not be possible to know the time of failure by direct inspection. In such cases the probability of failure can be determined from the past experience. Finding the Mean Time Between Failure (MTBF) of the equipment in past is one good way of finding this probability. It is possible by using the probabilities to find the number of items surviving up to certain time period or the number of items failing in a particular time period.

In situation, when equipment/item fails without any notice, two types of situation arise.

- a. **Individual Replacement Policy.** In this case an item is replaced immediately when it fails.
- b. **Group Replacement Policy.** In this policy all the items are replaced irrespective of the fact whether the item have failed or not, of course, any item failing before the time fixed for group replacement is also replaced.

3.4 INDIVIDUAL REPLACEMENT POLICY

In this policy a particular time ' t ' is fixed to replace the item whether it has failed or not. It can be done when one knows that an item has been in service for a particular period of time and has been used for that time period. In case of moving parts like bearings this policy is very useful to know when the bearing should be replaced whether it fails or not. Failure of a bearing can cause a lot of damage to the equipment in which it is fitted and the cost of repairing the equipment is much more than the cost of bearing if it had been replaced well in time. If it is possible to find out the optimum service life ' t ' the sudden failure and hence loss to the equipment and production loss etc can be avoided. However, when we replace items on a fixed interval of preventive maintenance period certain items may be left with residual useful life which goes waste. Such items could still perform for another period of time (not know) and so the utility of items has been reduced. Consider the case of a city corporation wanting to replace its street lights. If individual replacement policy is adopted then replacement can be done simultaneously at every point of failure. If group replacement policy is adopted then many lights with residual life will be replaced incurring unnecessary costs.

Analysis of the cost of replacement in case of items/equipments that fail without warning is similar to finding out the probability of human deaths or finding out the liability of claims of life-insurance company on the death of a policy holder.

The probability of failure or survival at different times can be found out by using mortality tables or life tables

The problem of human births and deaths as also individual problems where death is equivalent to failure and birth is equivalent to replacement can also be studied as part of the replacement policy. For showing such problems, we make the following assumptions.

- a. All deaths or past failures are immediately replaced by births or part replacements and
- b. There are no other, except the ones under consideration, entries or exits.

Let us find out the rate of deaths that occur during a particular time period assuming that each item in a system fails just before a particular time period. The aim is to find out the optimum period of time during which an item can be replaced so that the costs incurred are minimum. Mortality or life tables are used to find out the probability distribution of life span of items in the system.

Let $f(t)$ – number of items surviving at time $(t-1)$ n = Total number of item with system under consideration. The probability of failure of items between ‘ t ’ and $(t-1)$

can be found out by $P = \left(\frac{(t-1) - f(t)}{n} \right)$

Replacement Policy

Let the service life time of an item be T and n = number of items in a system which need to be replaced whenever any of these fails or reaches T .

$F(t)$ = number of items surviving at T

$F'(t) = 1 - f(t)$ number of items that have failed

$O(t)$ = Total operating time

C_f = cost replacement after failure of item

CPM = Cost of preventive maintenance

Cost of replacement after failure of service time $T = n \times f'(T) \times C_f$

also Cost of replacement for item replaced before failure = $n[1 - f'(T)] \times C_{pm}$

$$= n + f'(T) C_f + n[1 - f'(T)] C_{pm}$$

Hence we can replace an item when the total replacement cost given above is minimum where

$$O(t) = \int f(t) dt$$

3.5 GROUP REPLACEMENT POLICY

Under this policy all items are replaced at a fixed interval ‘ t ’ irrespective of the fact they have failed or not and at the same time keep replacing the items as and when they fail. This policy is applicable to a case where a large number of identical low cost items which are more and more likely to fail at a time. In such cases. *i.e.* like the

case of replacement of street light bulbs, it may be economical to replace all items at fixed intervals.

Let n = total number of items in the system

$N t$ = number of items that fail during time t '

$C(t)$ = Cost of group replacement after time t '

$C g$ = Cost of group replacement

Cf = Cost replacing one item on failure

$C(t) = n C g + Cf(n_1 + n_2 + \dots + n_{t-1})$

$F(t) = \text{Average cost per unit time} = C(t)/t = n C g + Cf(n_1 + n_2 + \dots + n_{t-1})/t$

We have to minimize average cost per unit time, so optimum group replacement time would be that period which minimize this time

It can be concluded that the best group replacement policy is that which makes replacement at the end of 't' th period if the cost of individual replacement for the same period is more than the average cost per unit time.

Example 4. *The following mortality rates have been observed for certain type of light bulbs.*

End of week	1	2	3	4	5
Percentage Failing	10	20	50	70	100

There are 1000 bulbs in use and it costs # 10 to replace an individual bulb which has burnt out. If all the bulbs are replaced simultaneously, it would cost # 5 per bulb. It is proposed to replace all the bulbs at fixed intervals whether they have fixed or not and to continue replacing fused bulbs as and when they fail.

At what intervals should all the bulbs be replaced so that the proposal is economical?

Sol. Average life of a bulb in weeks = Probability of failure at the end of week x number of bulbs

$$= (1 \times 10/100 + 2 \times 10/100 + 3 \times 30/100 + 4 \times 20/100 + 5 \times 30/100)$$

$$= 0.10 + 0.2 + 0.9 + 0.8 + 1.5 = 3.5$$

Average number of replacement – number of bulbs = $1000 = 288$

Per week average life 3.5

Cost per week @ # 10 per bulb = $285 \times 10 = \# 2850$

Let n_1, n_2, n_3, n_4 and n_5 be the number of bulbs being replaced at the end of first second, third, fourth and fifth week respectively then.

n_1 = number of bulbs in the beginning of the first week x probability of the bulbs failing during first week = $1000 \times 10/100 = 100$

n_2 = (number of bulbs in the beginning x probability of the bulbs failing during second week) + number of bulbs replaced in first week x probability of these replaced bulbs failing in second week

$$= 1000 \times (20 - 10)/100 + 100 \times 10/100 = 100 + 10 = 110$$

n_3 = (number of bulbs in the beginning x probability of the bulbs failing during third week) + number of bulbs being replaced in first week x probability of these

replaced bulbs failing in second week) + number of bulbs replaced in second week probability of those failing in third week)

$$= 100 \times (50 - 20) / 100 + 100 \times (20 - 10) / 100 + 110 + 10 / 100 = 300 + 10 + 11 =$$

321

$$n_4 = 1000 \times (70 - 50) / 100 \times (50 - 20) / 100 + 110 + 20 - 10 / 100 + 321 \times 10 / 100$$

$$= 200 + 30 + 11 + 32 = 273$$

$$N_5 = 100 \times 30 / 100 + 100 \times 20 / 100 + 110 \times 30 / 100 + 321 \times 10 / 100 + 273 \times 10 / 100$$

$$= 300 + 20 + 33 + 32 = 413$$

The economics of individual or group replacement can be worked out as shown in the table below

End of week	No. of bulbs failing	Cumulative No of failed bulbs	Cost of individual replacement	Cost of group replacement	Total cost	Average total cost
1	100	100	1000	5000	6000	6000
2	110	220	2200	5000	7200	3600
3	321	541	5410	5000	10410	3470
4	273	814	8140	5000	13140	3285
5	413	1227	12270	5000	17270	3454

Individual replacement cost was worked out to be # 2850. Minimum average cost per week corresponding to 4th week is # 3285, it is more than individual replacement cost. So it will be economical to follow individual replacement policy

Example 5. An automatic machine uses 250 moving parts as part of its assembly. The average cost of a failed moving part is # 200. Removing the failed part and replacing it is time consuming and disrupts manufacture. Due to this problem, the management is considering group replacement policy if replacing all the moving parts at a specific interval. What replacement policy should the manufacturer adopt? The information regarding the machine break down and the cost is as given below:

<i>Use time in months</i>	1	2	3	4	5	6
<i>Probability failure</i>	0.05	0.05	0.10	0.15	0.25	0.40
<i>Replacement Cost</i>						
<i>Individual Replacement</i>	<i>Purchase</i>	<i>Installation</i>				<i>Total</i>
		200	500			700
<i>Group Replacement</i>	150	200				350

Sol. Let us find out the average life of a moving part

Months	Prob of failure	Month X Probability
1	0.05	.05
2	0.05	0.10
3	0.10	0.30
4	0.15	0.60

5	0.25	0.75
6	0.40	2.40

Total = 4.20

Average number of replacement per month = Number of moving parts = $250/4.20 = 60$

Average cost per month when the moving part is individually replaced $60 \times 700 = 42000$

Now, we must find out the failure of the moving parts per month

Let n_1, n_2, \dots, n_6 be the number of moving parts failing at the end of first, second... sixth month

n_1 = number of parts in the first month x probability of a part failing in first month

$$= 250 \times 0.05 = 12.5 = 13$$

$$n_2 = n_0p_1 + n_1p_1 = (250 \times 0.05) + 13 \times 0.05 = 12.5 + .65 = 13.15 = 14$$

$$n_3 = n_0p_3 + n_1p_2 + n_2p_1 = 250 \times 0.10 + 13 \times 0.05 + 14 \times 0.5 = 26.35 = 27$$

$$n_4 = n_0p_4 + n_1p_3 + n_2p_2 + n_3p_1 = 250 \times 0.15 + 13 \times 0.10 + 14 \times 0.05 + 27 \times 0.05$$

$$= 37.5 + 1.3 + 0.7 + 1.35 = 40.85 = 41$$

$$n_5 = n_0p_5 + n_1p_4 + n_2p_3 + n_3p_2 + n_4p_1 = 250 \times 0.25 + 13 \times 0.15 + 14 \times 0.10 + 27 \times 0.05$$

$$= 62.5 + 1.95 + 1.4 + 1.35 = 67.2 = 68$$

$$n_6 = n_0p_6 + n_1p_5 + n_2p_4 + n_3p_3 + n_4p_2 + n_5p_1$$

$$= 250 \times 0.40 + 13 \times 0.25 + 14 \times 0.15 + 27 \times 0.10 + 41 \times 0.05 + 68 \times 0.05$$

$$= 100 + 3.25 + 2.1 + 2.7 + 2.05 + 3.4 = 113.5 = 114$$

Total Average cost can be found out with the help of following table

Month	No of moving part failed	Cumulative failure	Individual replacement	Group replacement	Total cost	Average Total Cost
1	13	13	9100	$350 \times 250 =$ # 87500	96600	96600
2	14	27	18900		106400	53200
3	27	54	37800		125300	41767
4	41	95	66500		154000	385500
5	68	16.3	114100		201600	40320
6	114	227	193900		281400	46900

It can be seen that the average total cost in third month *i.e.* # 38500 is the minimum, the optimum group replacement period is 3 months. Also the individual replacement cost of# 42000 is more than the minimum group replacement cost of #. 38500, group replacement is a better policy.

3.5 MANPOWER REPLACEMENT POLICY (STAFFING POLICY)

All organizations face the problem of initial recruitment and filling up of vacancies caused by promotion, transfer, employee quitting their jobs or retirement and deaths. The principle of replacement used in industry for replacement of parts etc can also be used for recruitment and promotion policies, which are laid down as personnel policy of an organization. The assumption made in such case is that the destination of manpower is already decided. Few examples will illustrate this point

Example 6. *An army unit required 200 men, 20 junior commission officer (JCO's) and 10 officers. Men are recruited at the age of 18 and JCO's and officers are selected out of these. If they continue in service, they retire at the age of 40. At present there are 800 Igbo and every year 20 of them retire. How many Igbo should be recruited every year and at what age promotions should take place?*

Sol. If 800 *Igbo* had been recruited for the past 22 years (age of recruitment 40 years – age of entry 18 years), the total number of them serving up to age of 39 years = $20 \times 22 = 440$

Total number of *Igbo* required = $200 + 20 + 10 = 230$

Total number of *Igbo* to be recruited every year in order to maintain a strength of 230
 $= 800/440 \times 230 = 418$

Let a *Igbo* be promoted at age of X the up to X – 1 year number of *Igbo* recruited is 200 out of 230.

Hence out of 800, *Igbo* required = $200/230 \times 800 = 696$

696 will be available up to 5 years as 20 retire every year and $(800 - 20 \times 5) = 700$.

Hence promotion of *Igbo* is due in 6th years.

Out of 230 *Igbo* required, 20 are JCo's, therefore is recruited 800, number of JCO's = $20/230 \times 800 = 70$ approximately.

In a recruitment of 800, total number of men and JCO's = $697 + 70 = 766$

Number of officers required = $800 - 766 = 34$

This number will be available in 20 years of service, so promotion of JCO's to officers is due in 21 year of service.

11.0 CONCLUSION

As in summary

12.0 SUMMARY

1. Replacement decision analysis is a mathematical technique used to take decision as to when to replace an item that deteriorates or fails to function.
2. In deciding whether or not to replace an item one should consider, among other things, repair and maintenance cost, the scrap value of the assets, the purchase cost of the new item.
3. Two major replacement decision analysis are replacement of items that wear off gradually and replacement of items that fails suddenly.
4. For items that fail suddenly, we have group (en masses) or individual replacement policy.
5. IN replacement analysis the cost of replacement includes (a) Cost of items to be replaced (b) Cost of labour of replacing the failed item (c) Cost of damage done as a result of failed item (d) Cost of inconvenience to the user.
6. The average life span in individual replacement of items that fail suddenly is $\sum p_1 X_1$.
7. The average number of periodic replacement & operations research in decision analysis and production management = total number of items in use $N = \sum p_1$
8. Cost of individual replacement is $r C_t$ where C_t is the total cost of replacement of items.
9. Group replacement can be analysed using periodic failure table.
10. Challenges faced by equipment that wear gradually are problems of deterioration and maintenance.
11. The minimum cost point enables us to know the time when the equipment that in wearing out gradually should be replaced.

12. Replacement analysis can be used to advise the management of an organization as to whether items should be replaced individually or in group (en messes).

13. If cost of individual replacement on failure of items is greater than the average monthly cost of mass replacement at, say, end of second month, management would be advised to replace all items at the end of every second month.

13.0 TUTOR MARKED ASSIGNMENT

1. A taxi owner estimates from his past records that the cost per year for operating a taxi whose purchase price when new is Rs 60,000 are as given below:

Age		1	2	3	4
	5				
Operating cost (#)	10,000	12,000	15,000	18,000	20,000

After 5 years, the operating cost is # 6000k where $k = 6, 7, 8, 9, 10$ (k denoting age in years). If the resale value decreases 10% of purchase price per year, what is the best replacement policy? Cost of money is zero.

2. A machine system contains 4000 ICs and the present policy is to replace an IC as and when it fails. The average cost of replacing one IC is # 100. If all the ICs are replaced under a preventive maintenance policy, the average cost of IC comes down to # 50 Existing number of ICs at the end of the year and the probability of failing during the year is shown below:

Year	0	1	2	3	4	5	6
Present Functional ICs	1000	800	700	500	300	100	0
Probability of failure During the year	0.04	0.06	0.25	0.30	0.15	0.20	0.00

Compute the associated costs, if individual or group replacement policy is followed. Which policy should be adopted and why?

14.0 REFERENCES/FURTHER READING

1. Operations Research. By Prem Kumar Gupta and D.S. Hira
2. Operations Research. (Problem Solvers) By Research and Education Association.
31. Statistics and Operations Research. By Debashis Dutta
32. Operations Research By). O.T. Arowolo and G.O. Lawal

